

AUGER: SURFACE DETECTOR ELECTRONIC UPGRADE

VERSION: 1.12

DATE: 21/03/2016

BILL OF MATERIAL: X002-002-IE00-VA01



**PIERRE
AUGER**
OBSERVATORY

REF: /CAO-PROJETS/SPB16X/LAGORIO/AUGER/SDEU/IE00/

LPSC
53, AVENUE DES MARTYRS
38026 GRENOBLE CEDEX
+33 (0)4.76.28.41.65

ETUDE: SDEU

PAGE: 1/32

DESSIN: EL & JB

DATE: 22/03/2016

COVER PAGE

COVER PAGE	PAGE 1
HIERARCHY	PAGE 2
TOP SCHEMATIC & RADIO, TANK, TRIGGERS, PMTS, GPS, POWER CONNECTORS	PAGE 3
DDR2_FPGA : ZYNQ FPGA, LP-DDR2 MEMORY, STORAGE MEMORY & WATCHDOG	
QSPI, JTAG, RESET, CLOCK, WATCHDOG, UART USB INTERFACE, FLASH MEMORY SLOW-CONTROL I2C, SYS UART, VCO SPI, FPGA BANK 0 & 500	PAGE 23
LP-DDR2, RADIO RS232 INTERFACE, FPGA BANK 501 & 502	PAGE 24
FPGA BANK 13, 33, 34 & 35	PAGE 25
FRONT END	
3X TWIN ADCS TYPE 1, 1X TWIN ADCS TYPE 2 & 1X TWIN ADCS TYPE 3	PAGE 14
TWIN ADCS TYPE 1	PAGE 18, 19 & 20
TWIN ADCS TYPE 2	PAGE 17
TWIN ADCS TYPE 3	PAGE 16
VOLTAGE REFERENCES	PAGE 15
ETHERNET_USB-OTG	PAGE 4
CLOCK_GENERATOR	PAGE 6
SLOW_CONTROL : SLOW-CONTROL SYSTEM , PMTS, RADIO & TANK CONNECTORS	
SLOW_CONTROL, MICRO-CONTROLLER	PAGE 12
SLOW_CONTROL, ANALOG LEVELS	PAGE 13
LED_CONTROLLER	
MAIN SCHEMATIC	PAGE 7
SPARE COMPONENTS	PAGE 8
EXT_CONNECTORS	PAGE 21 & 22
UART_USB : RS232 / USB INTERFACE	PAGE 5 & 26
POWER_UUB	
PROTECTION, RADIO & PMTS 12V	PAGE 9
1.2V, 1.8V, 3.3V, +3.3V & -3.3V	PAGE 10
SLOW-CTRL 3.3V, 1V AND 5V	PAGE 11
ESD_8	PAGE 27, 28 & 29
ESD_12	PAGE 30, 31 & 32

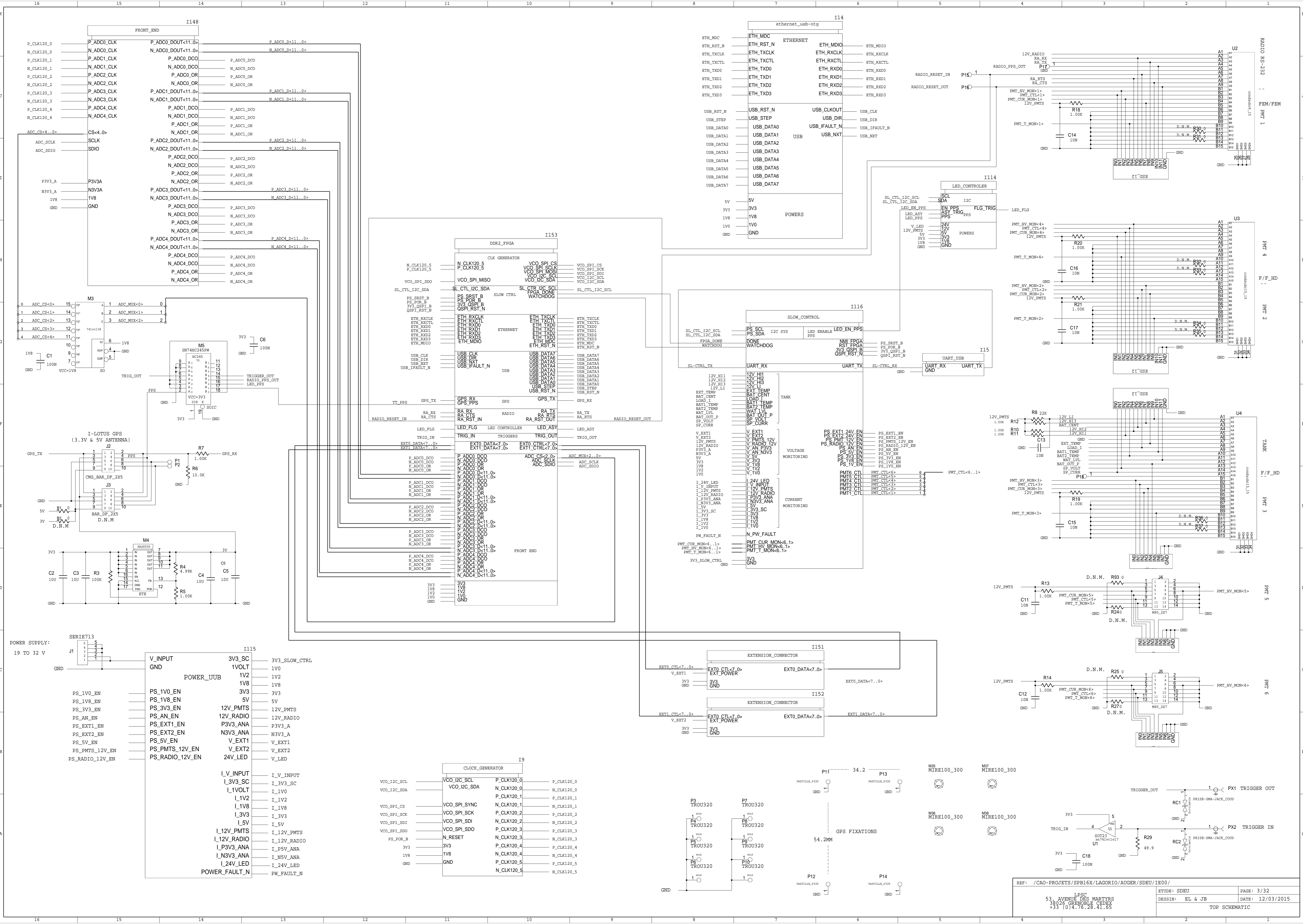

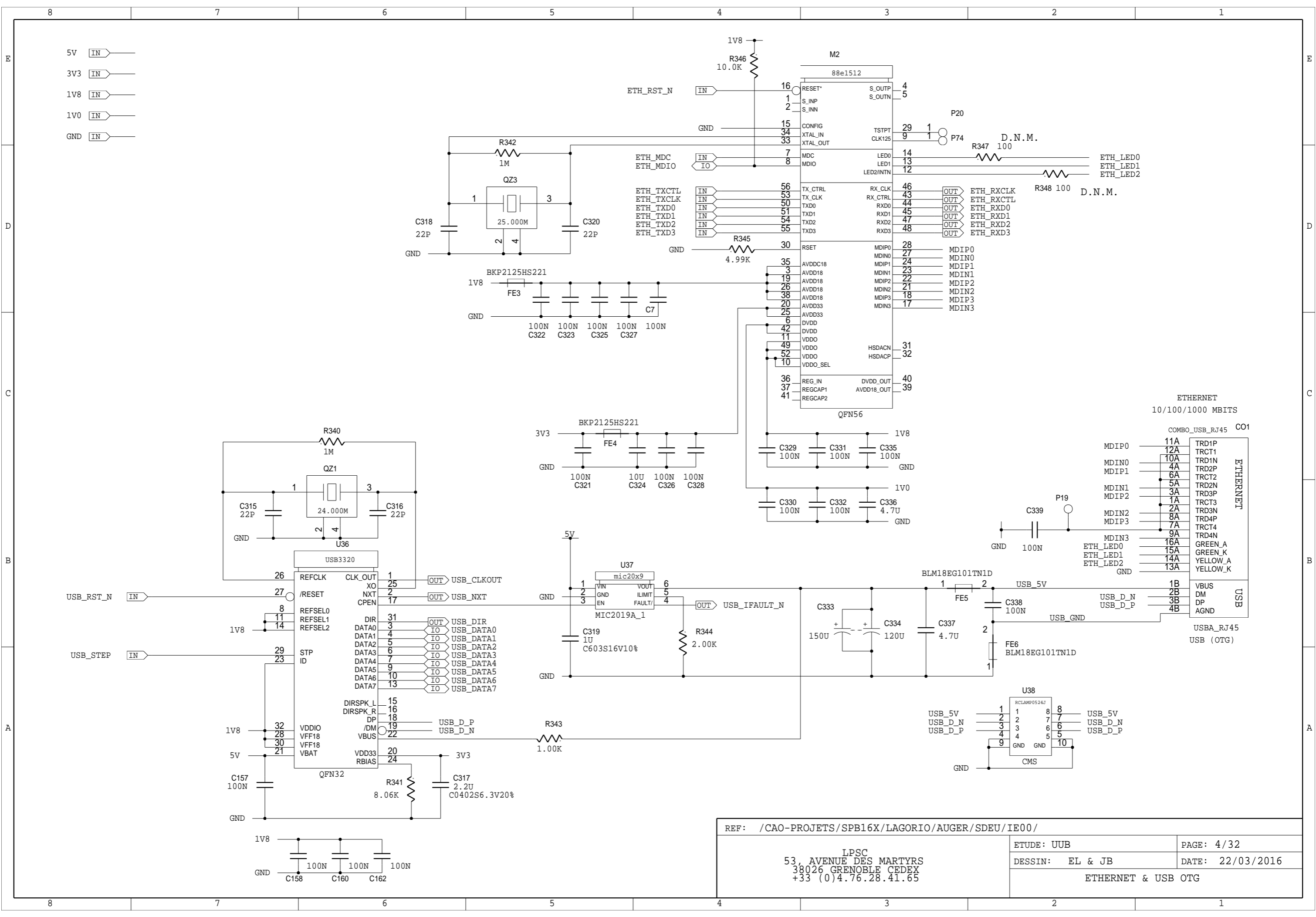

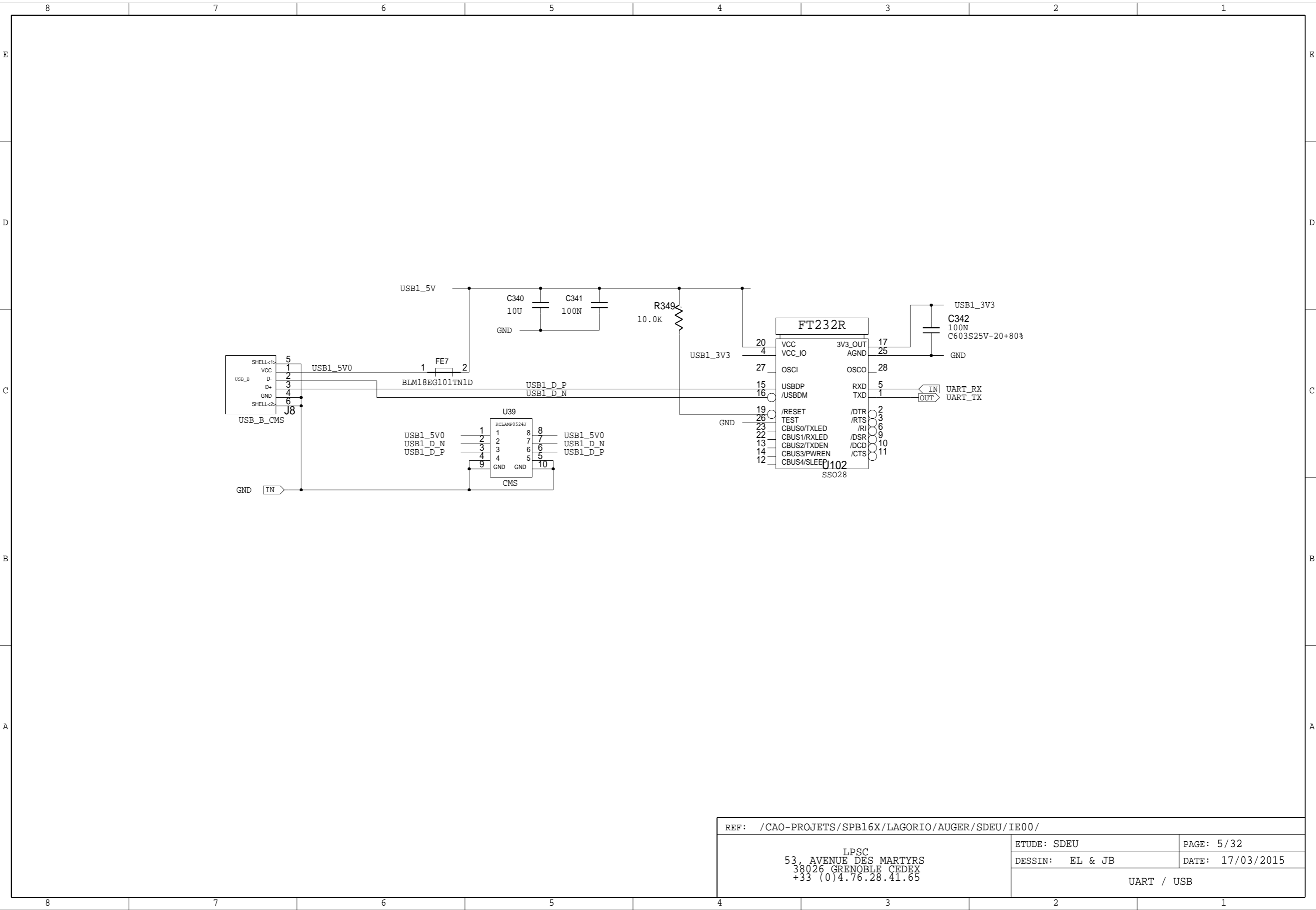

REF: /CAO-PROJETS/SPB16X/LAGORIO/AUGER/SDEU/IE00/		
LPSC 53, AVENUE DES MARTYRS 38026 GRENOBLE CEDEX +33 (0)4.76.28.41.65	ETUDE: SDEU	PAGE: 5/32
	DESSIN: EL & JB	DATE: 17/03/2015
UART / USB		

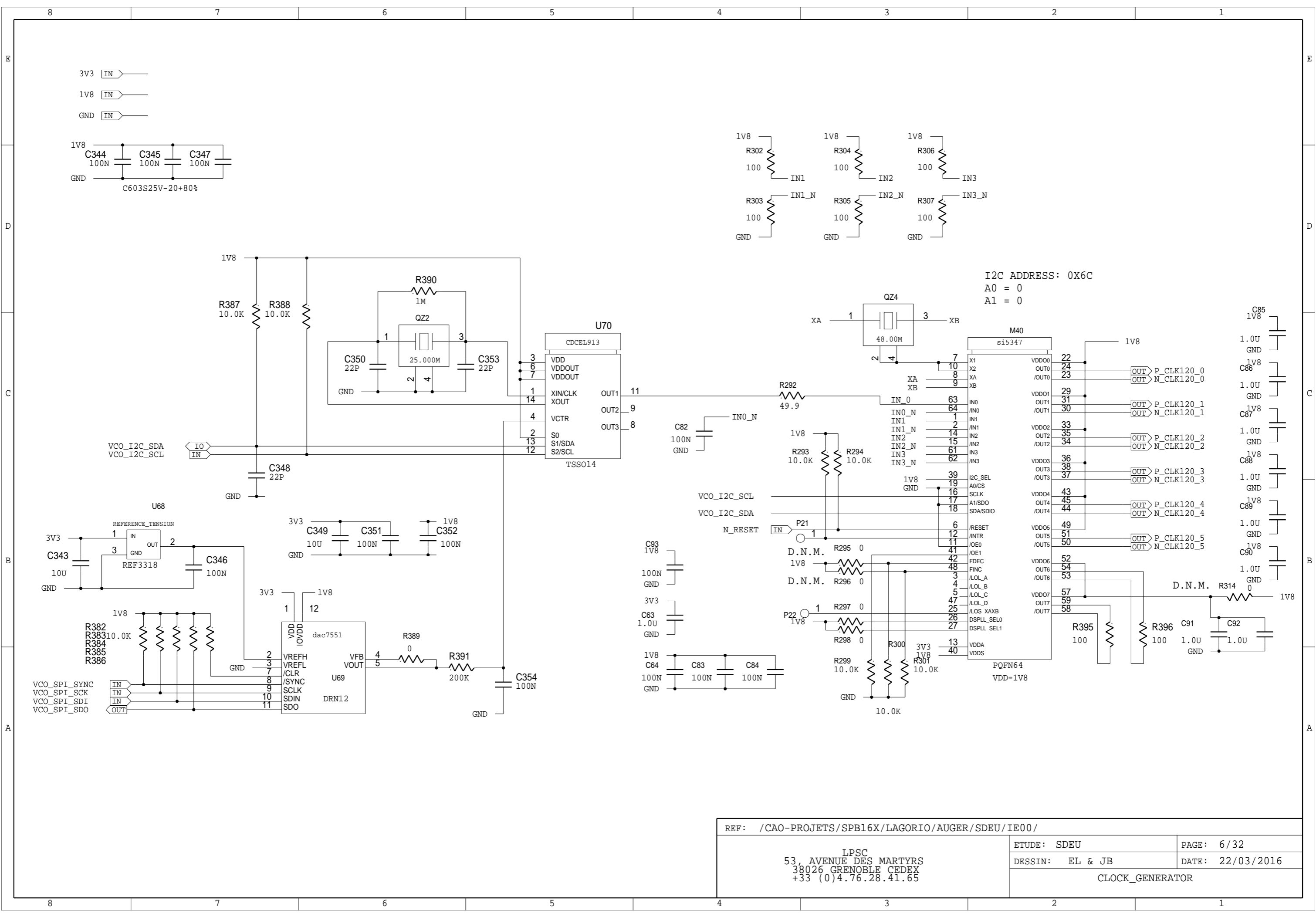

I2C ADDRESS: 0X6C
 A0 = 0
 A1 = 0

REF: /CAO-PROJETS/SPB16X/LAGORIO/AUGER/SDEU/IE00/		
LPSC 53, AVENUE DES MARTYRS 38026 GRENOBLE CEDEX +33 (0)4.76.28.41.65	ETUDE: SDEU	PAGE: 6/32
	DESSIN: EL & JB	DATE: 22/03/2016
CLOCK_GENERATOR		

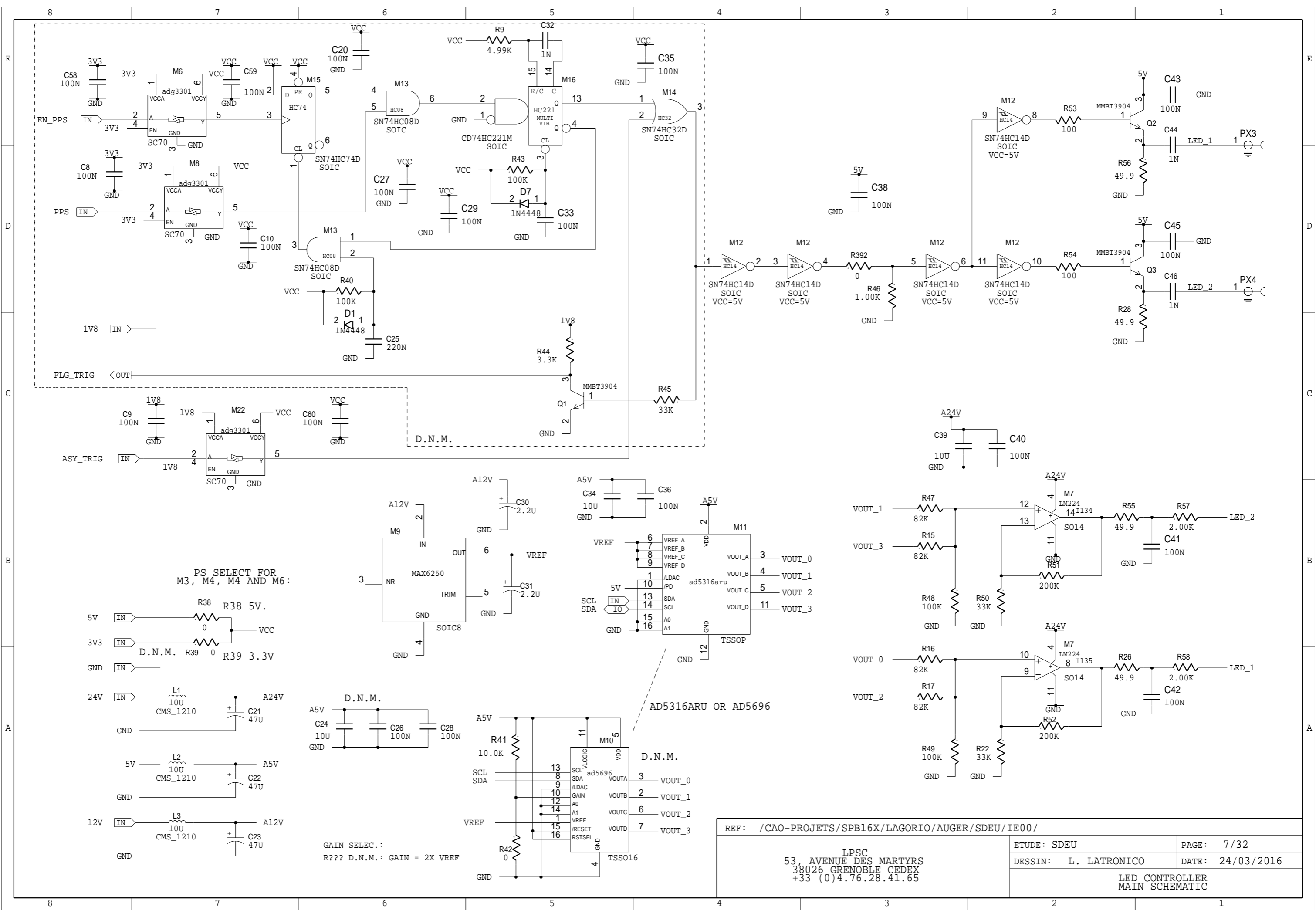

PS SELECT FOR M3, M4, M4 AND M6:

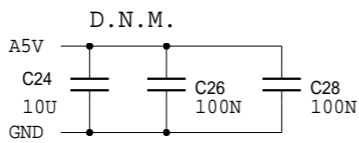
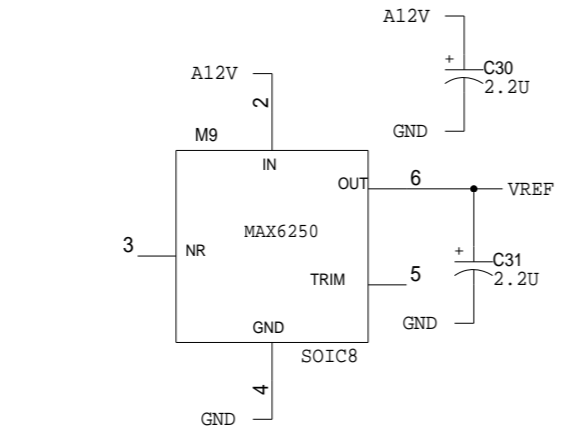
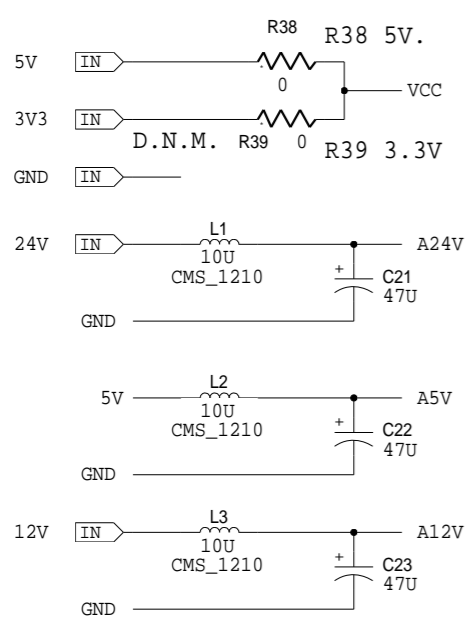

GAIN SELEC.:
 R??? D.N.M.: GAIN = 2X VREF

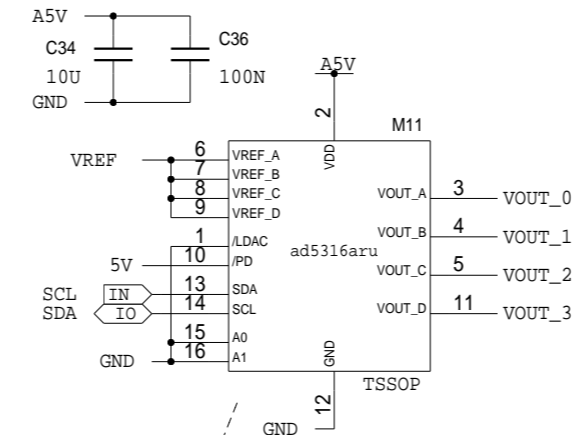

AD5316ARU OR AD5696

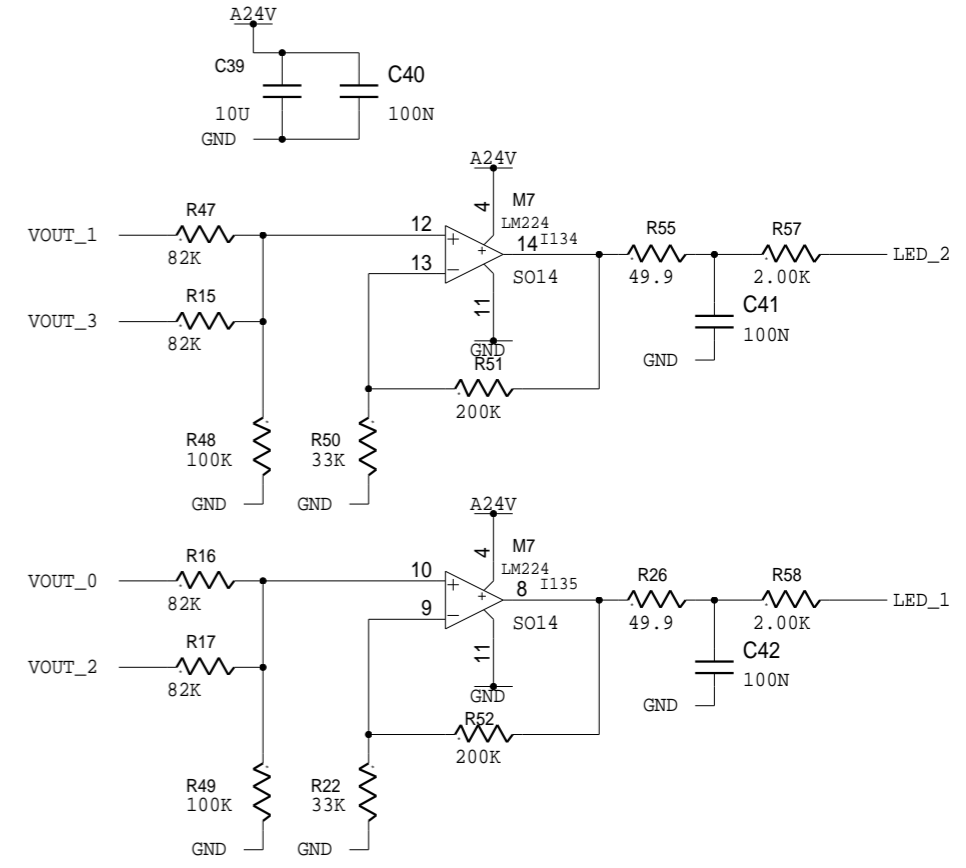
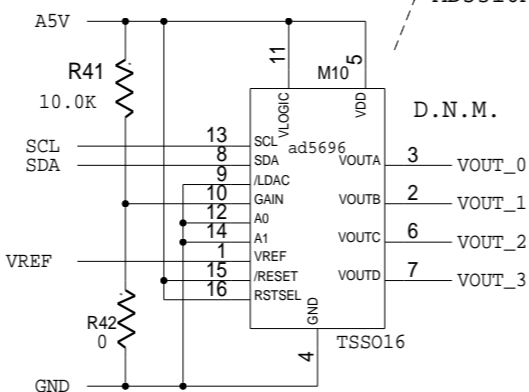

D.N.M.

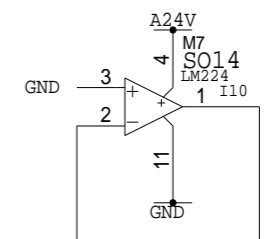
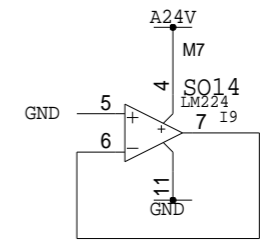
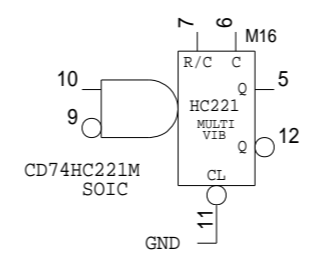
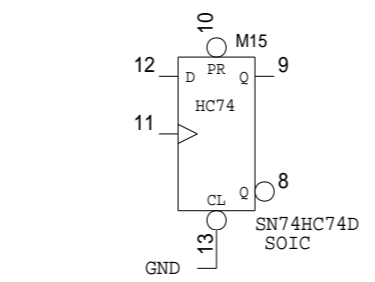
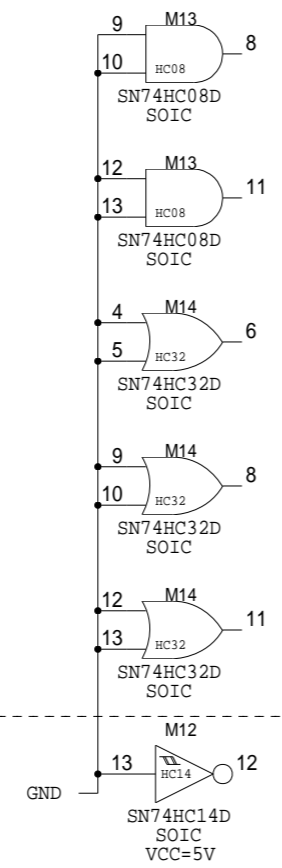

REF: /CAO-PROJETS/SPB16X/LAGORIO/AUGER/SDEU/IE00/		ETUDE: SDEU	PAGE: 8/32
LPSC 53, AVENUE DES MARTYRS 38026 GRENOBLE CEDEX +33 (0)4.76.28.41.65		DESSIN: L. LATRONICO	DATE: 22/03/2016
		LED CONTROLLER SPARE COMPONENTS	

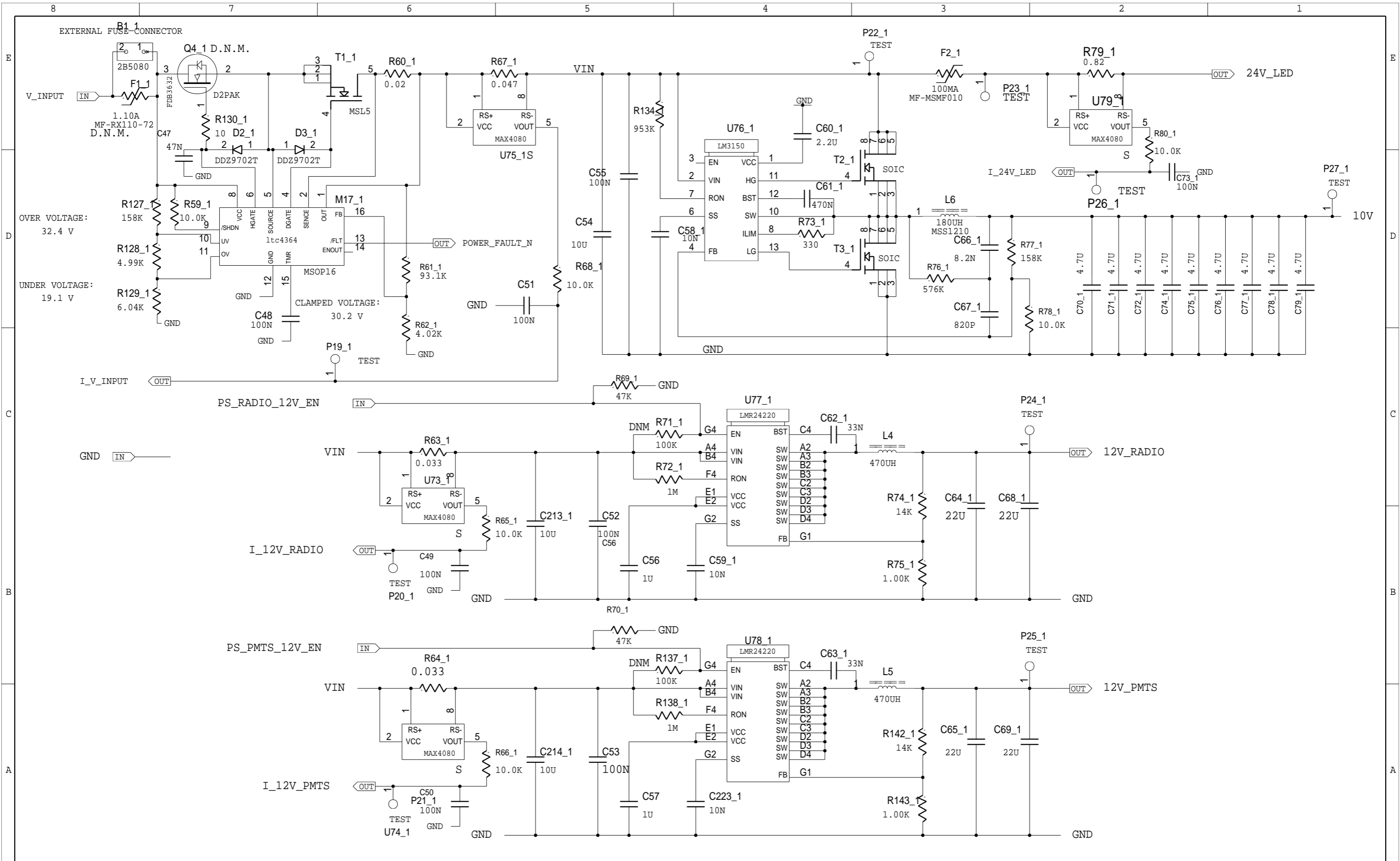

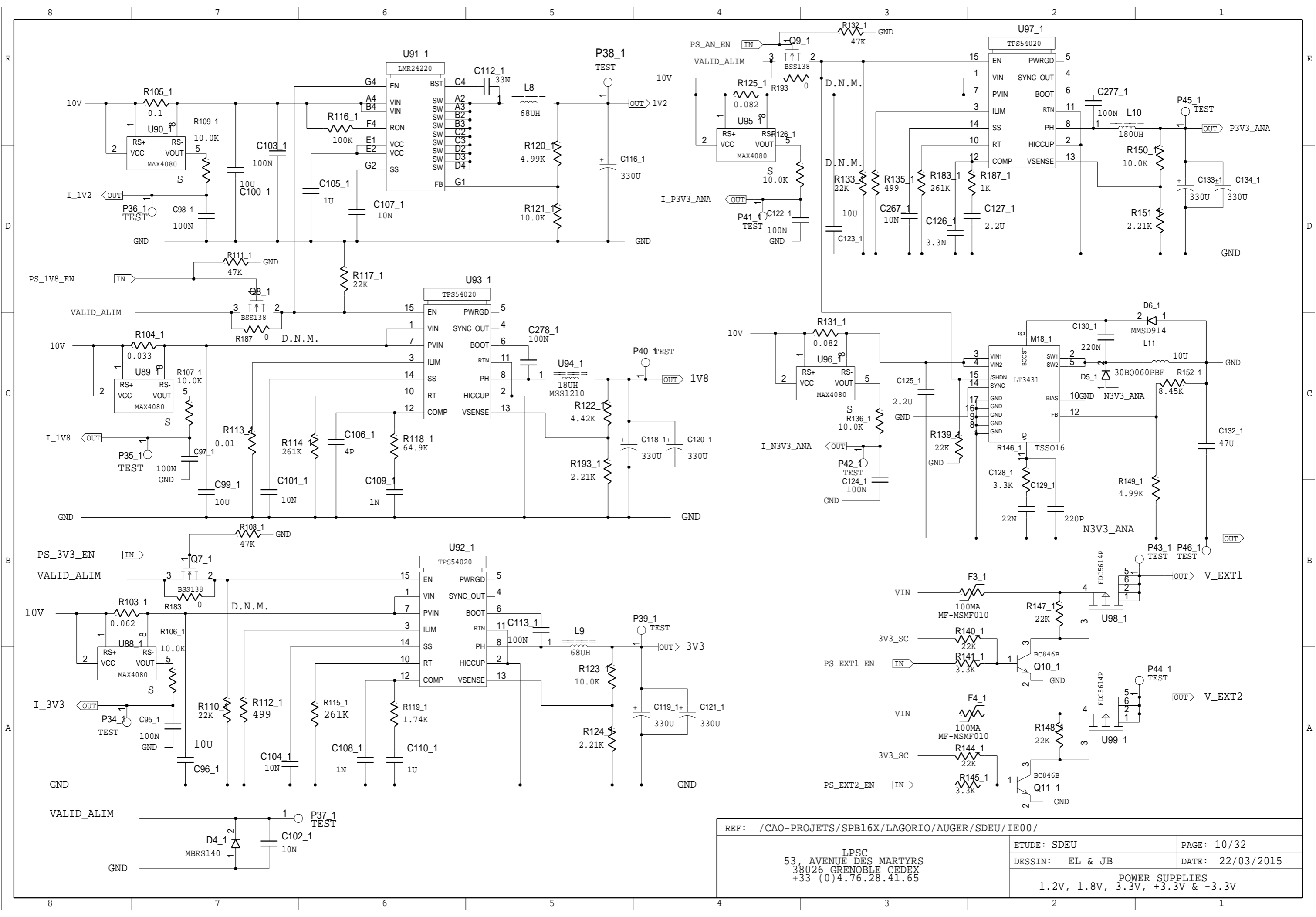

REF: /CAO-PROJETS/SPB16X/LAGORIO/AUGER/SDEU/IE00/		
ETUDE: SDEU		PAGE: 10/32
DESSIN: EL & JB		DATE: 22/03/2015
LPSC 53, AVENUE DES MARTYRS 38026 GRENOBLE CEDEX +33 (0)4.76.28.41.65		
POWER SUPPLIES 1.2V, 1.8V, 3.3V, +3.3V & -3.3V		

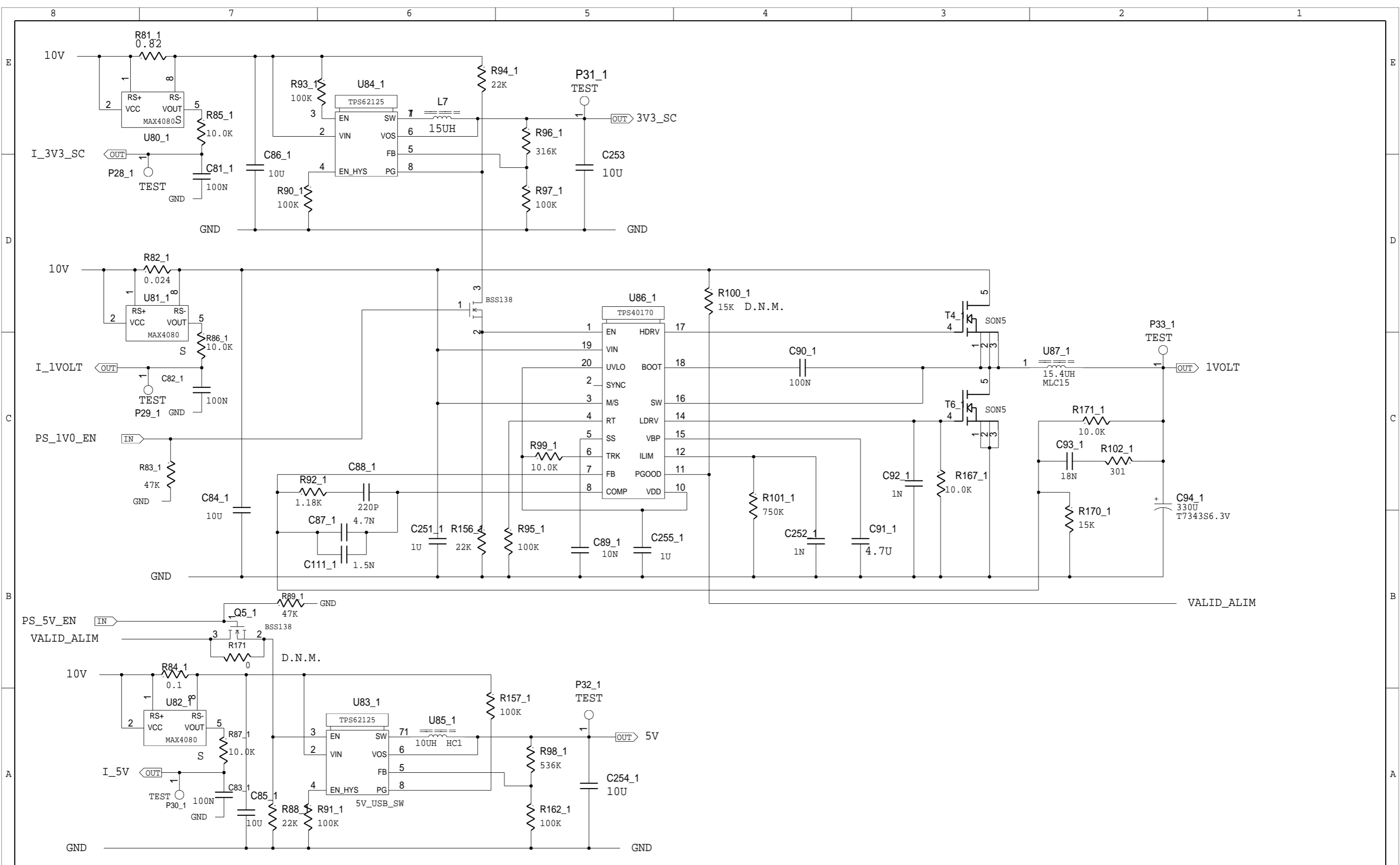

REF: /CAO-PROJETS/SPB16X/LAGORIO/AUGER/SDEU/IE00/		
LPSC 53, AVENUE DES MARTYRS 38026 GRENOBLE CEDEX +33 (0)4.76.28.41.65		ETUDE: SDEU DESSIN: EL & JB
		PAGE: 11/32 DATE: 22/03/2015
POWER SUPPLIES SLOW-CTRL 3.3V, 1V AND 5V		

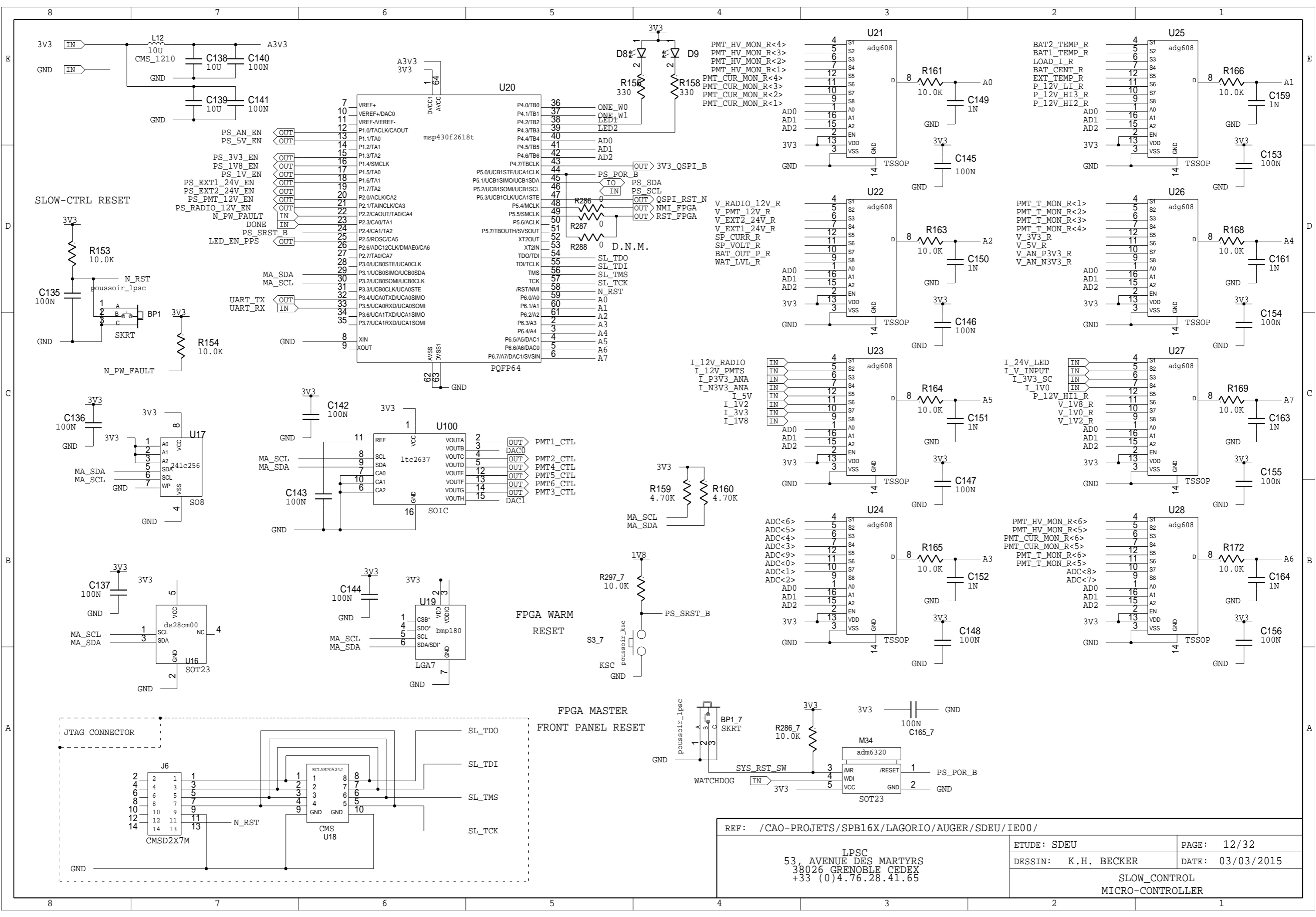

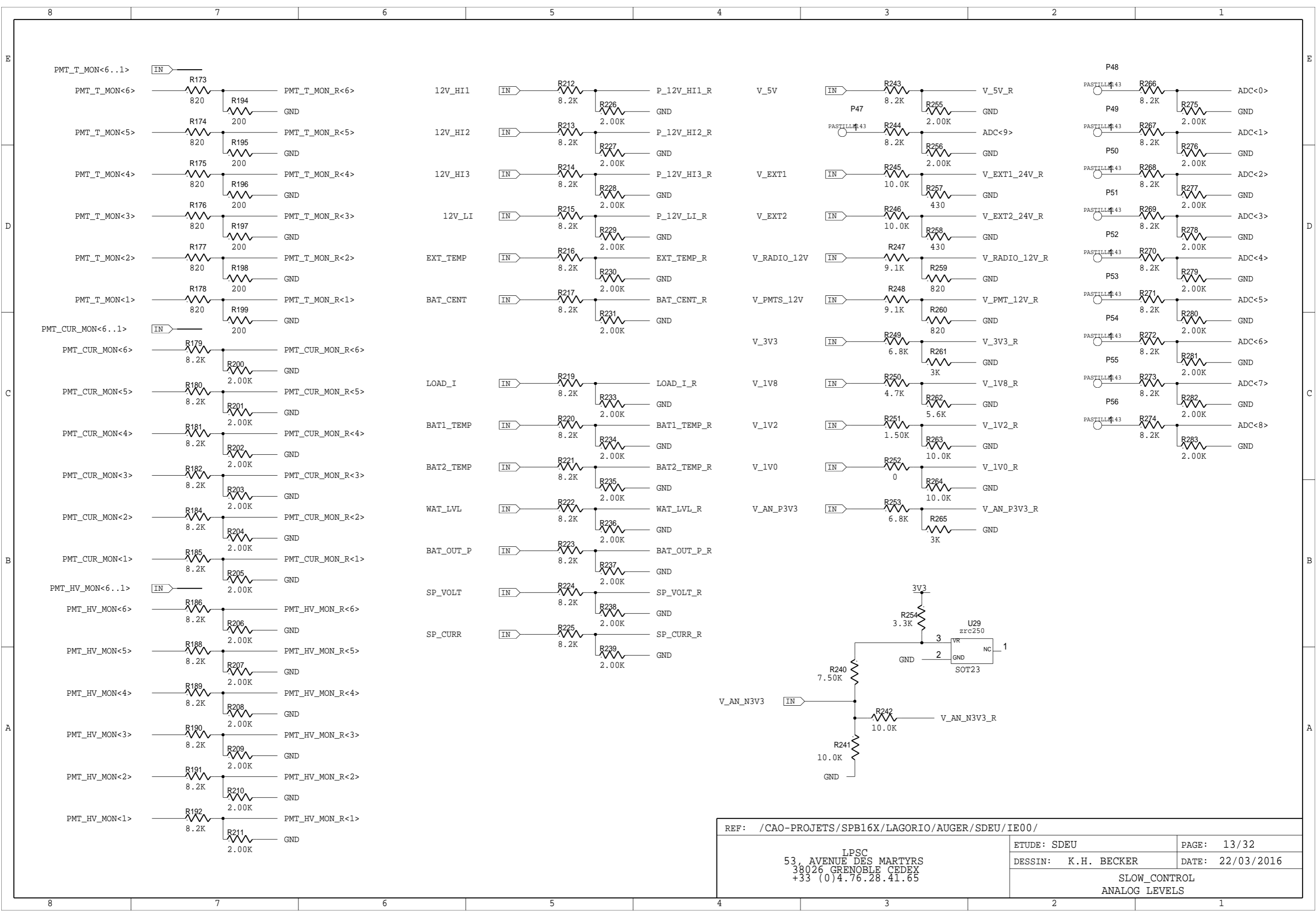

REF: /CAO-PROJETS/SPB16X/LAGORIO/AUGER/SDEU/IE00/		
LPSC 53, AVENUE DES MARTYRS 38026 GRENOBLE CEDEX +33 (0)4.76.28.41.65		ETUDE: SDEU DESSIN: K.H. BECKER
		PAGE: 13/32 DATE: 22/03/2016
SLOW CONTROL ANALOG LEVELS		

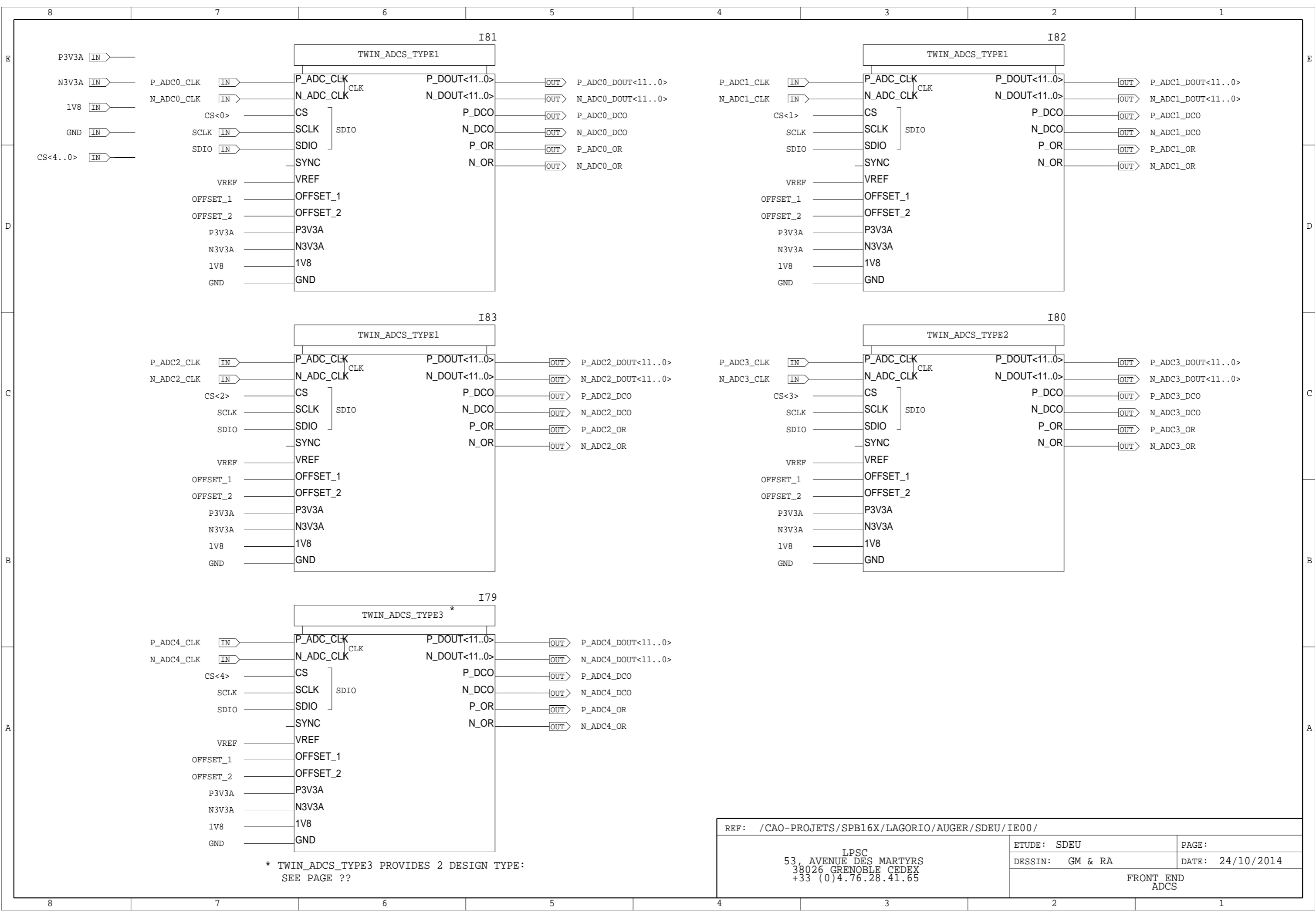

* TWIN_ADCS_TYPE3 PROVIDES 2 DESIGN TYPE:
SEE PAGE ??

REF: /CAO-PROJETS/SPB16X/LAGORIO/AUGER/SDEU/IE00/		ETUDE: SDEU	PAGE:
LPSC 53, AVENUE DES MARTYRS 38026 GRENOBLE CEDEX +33 (0)4.76.28.41.65		DESSIN: GM & RA	DATE: 24/10/2014
		FRONT END ADCS	

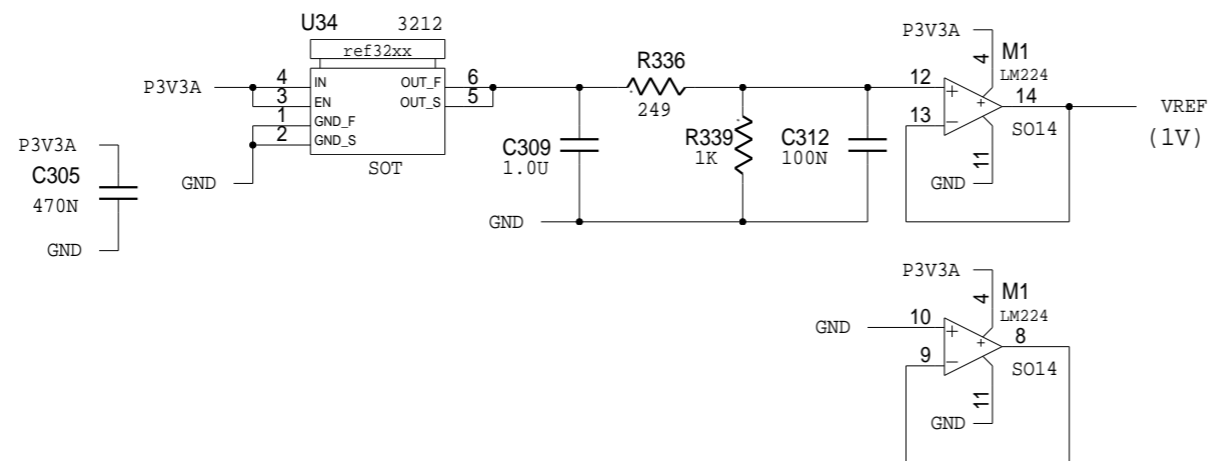
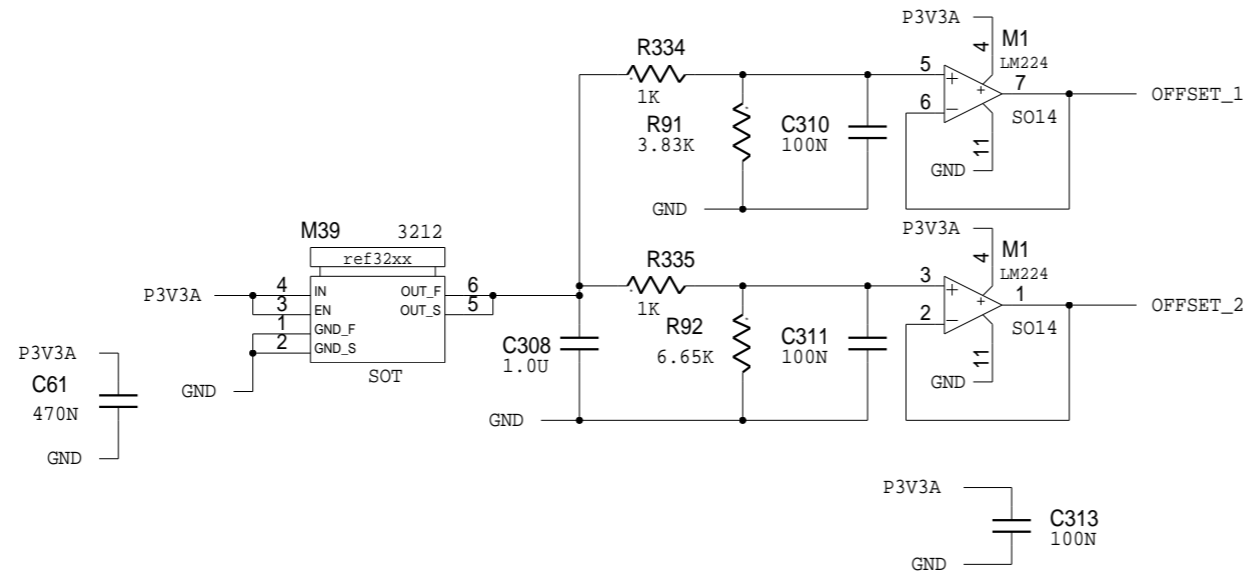

REF: /CAO-PROJETS/SPB16X/LAGORIO/AUGER/SDEU/IE00/

LPSC
53, AVENUE DES MARTYRS
38026 GRENOBLE CEDEX
+33 (0)4.76.28.41.65

ETUDE: SDEU

PAGE:

DESSIN: GM & RA

DATE: 22/03/2016

FRONT END
REFERENCE VOLTAGES

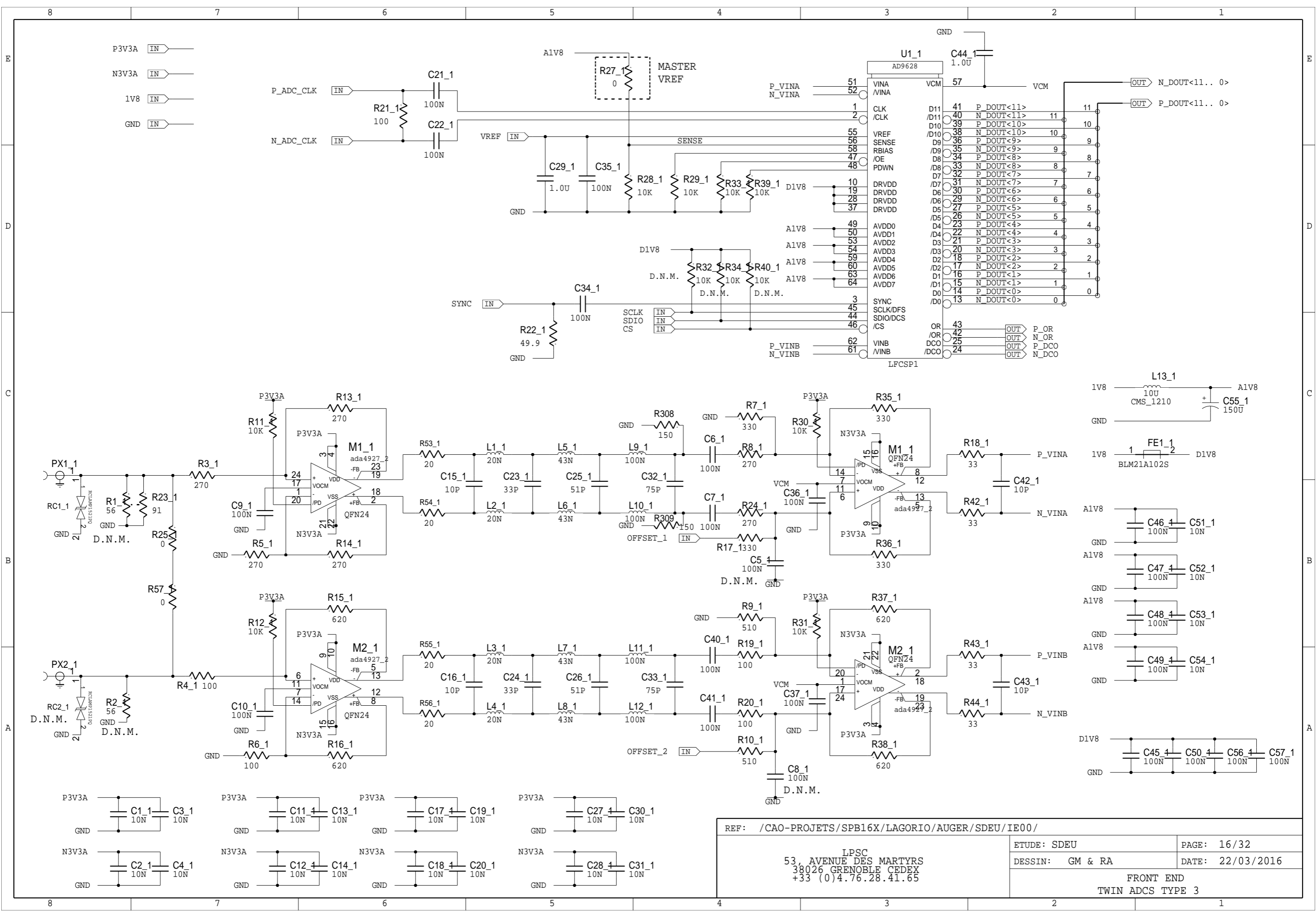

REF: /CAO-PROJETS/SPB16X/LAGORIO/AUGER/SDEU/IE00/

53, AVENUE DES MARTYRS
38026 GRENOBLE CEDEX
+33 (0)4.76.28.41.65

ETUDE: SDEU	PAGE: 16/32
DESSIN: GM & RA	DATE: 22/03/2016
FRONT END TWIN ADCS TYPE 3	

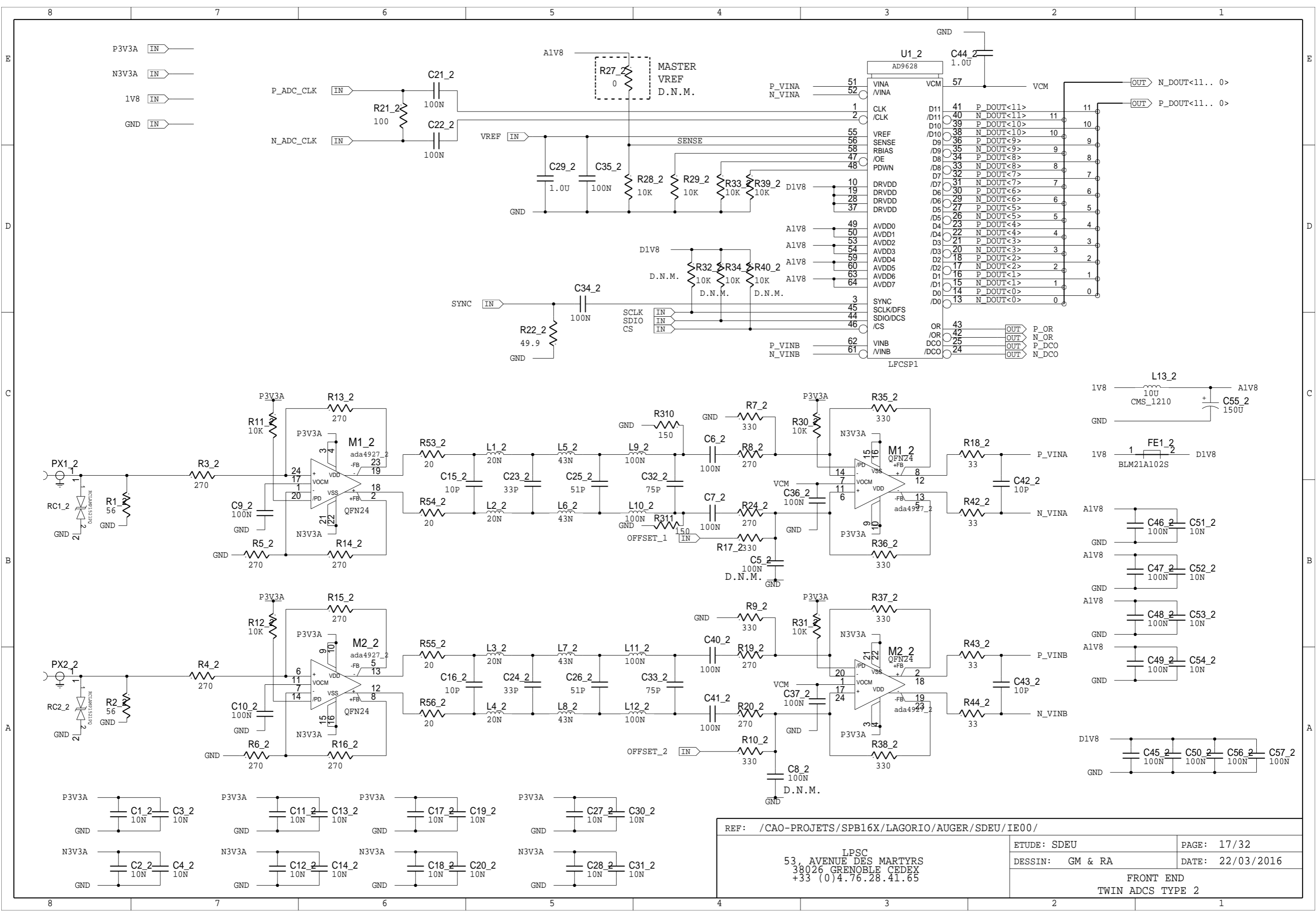

REF: /CAO-PROJETS/SPB16X/LAGORIO/AUGER/SDEU/IE00/

53, AVENUE DES MARTYRS
38026 GRENOBLE CEDEX
+33 (0)4.76.28.41.65

ETUDE: SDEU	PAGE: 17/32
DESSIN: GM & RA	DATE: 22/03/2016
FRONT END TWIN ADCS TYPE 2	

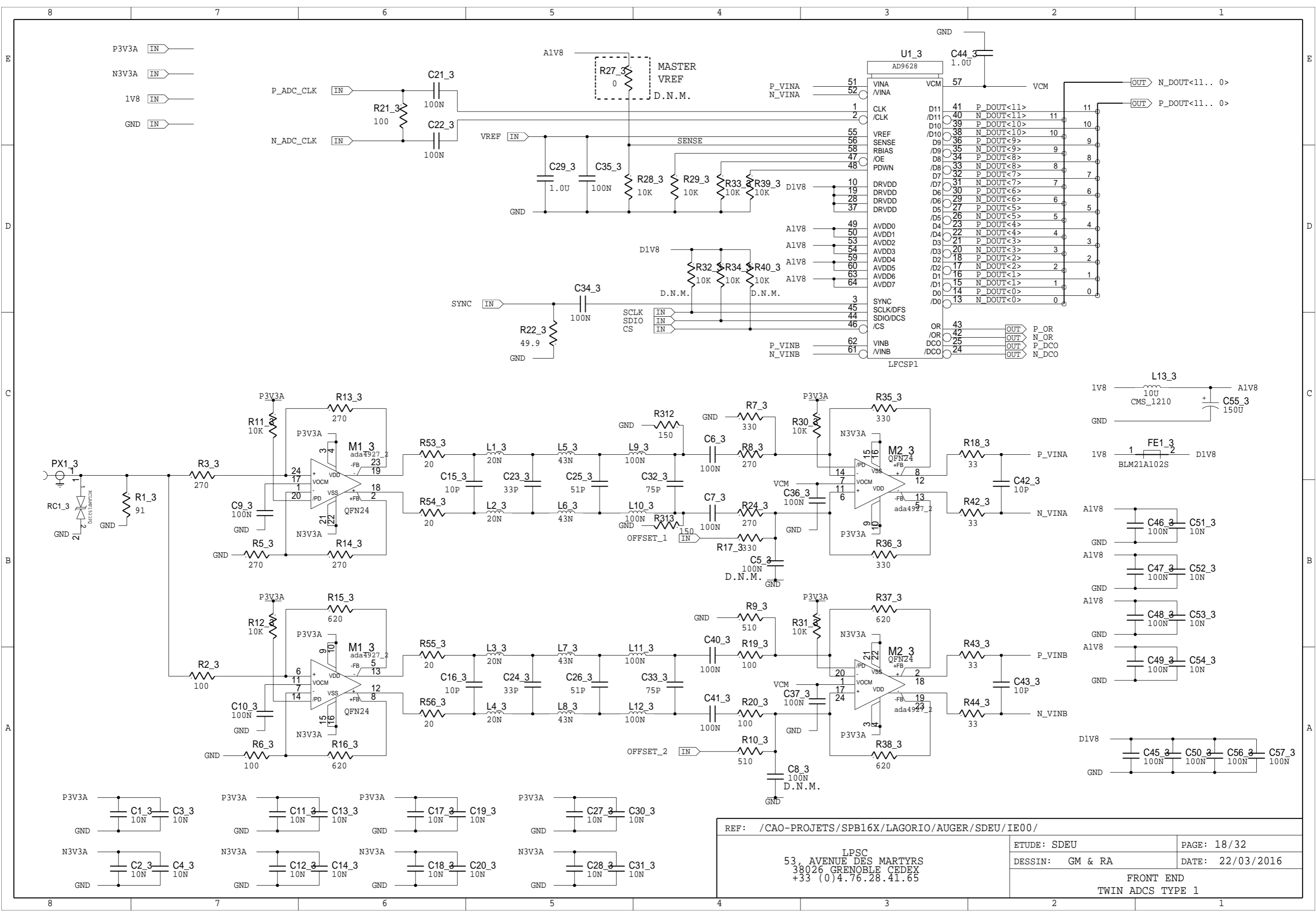

REF: /CAO-PROJETS/SPB16X/LAGORIO/AUGER/SDEU/IE00/

53, AVENUE DES MARTYRS
38026 GRENOBLE CEDEX
+33 (0)4.76.28.41.65

ETUDE: SDEU	PAGE: 18/32
DESSIN: GM & RA	DATE: 22/03/2016
FRONT END TWIN ADCS TYPE 1	

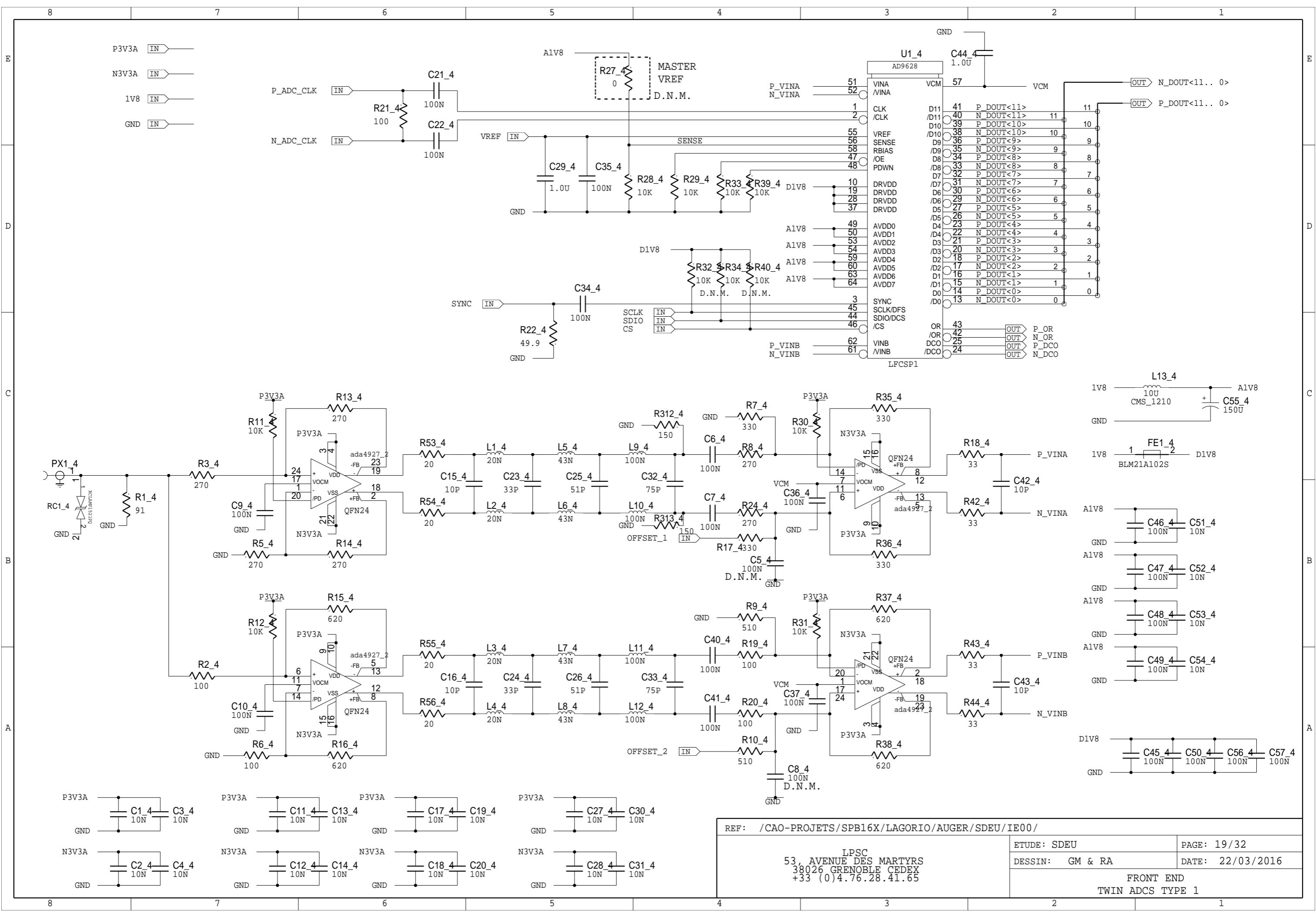

REF: /CAO-PROJETS/SPB16X/LAGORIO/AUGER/SDEU/IE00/

53, AVENUE DES MARTYRS
38026 GRENOBLE CEDEX
+33 (0)4.76.28.41.65

ETUDE: SDEU	PAGE: 19/32
DESSIN: GM & RA	DATE: 22/03/2016
FRONT END TWIN ADCS TYPE 1	

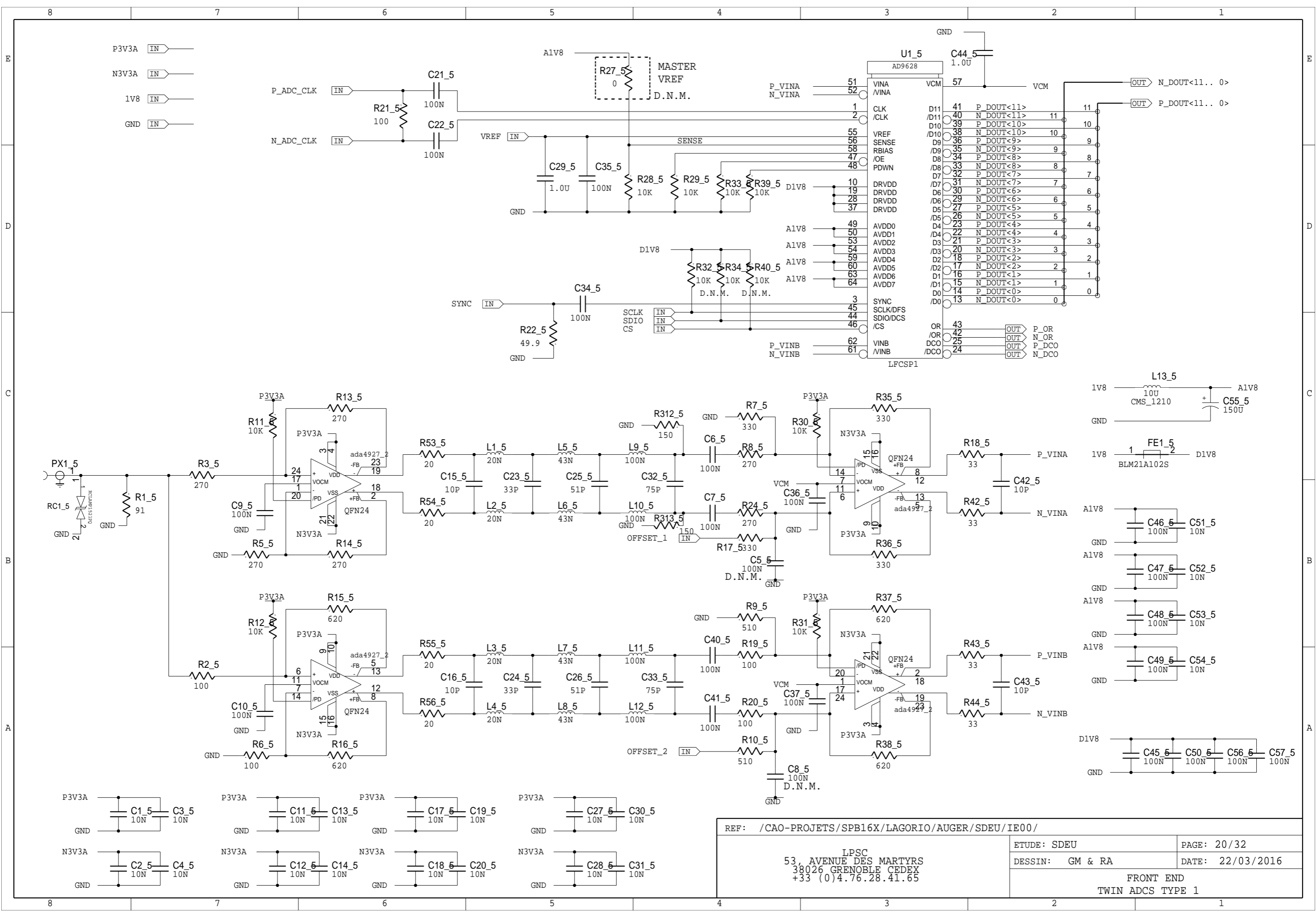

REF: /CAO-PROJETS/SPB16X/LAGORIO/AUGER/SDEU/IE00/

53, AVENUE DES MARTYRS
38026 GRENOBLE CEDEX
+33 (0)4.76.28.41.65

ETUDE: SDEU	PAGE: 20/32
DESSIN: GM & RA	DATE: 22/03/2016
FRONT END TWIN ADCS TYPE 1	

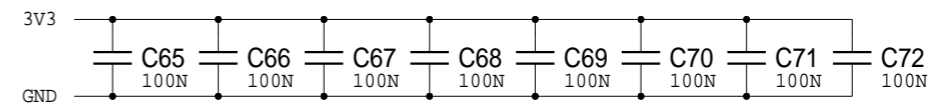
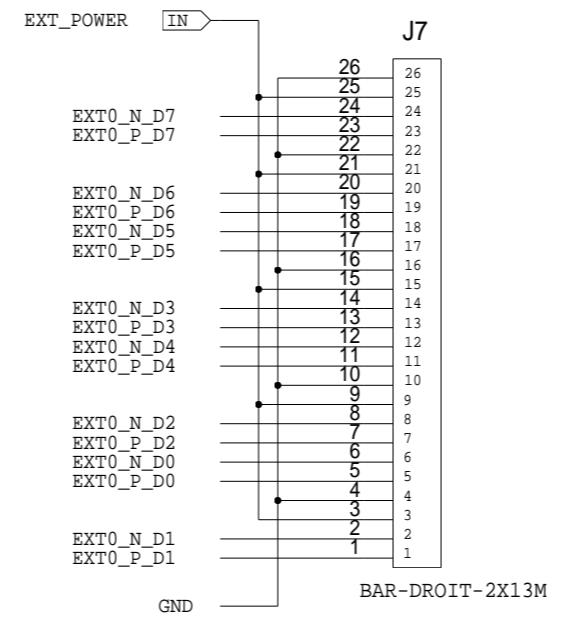
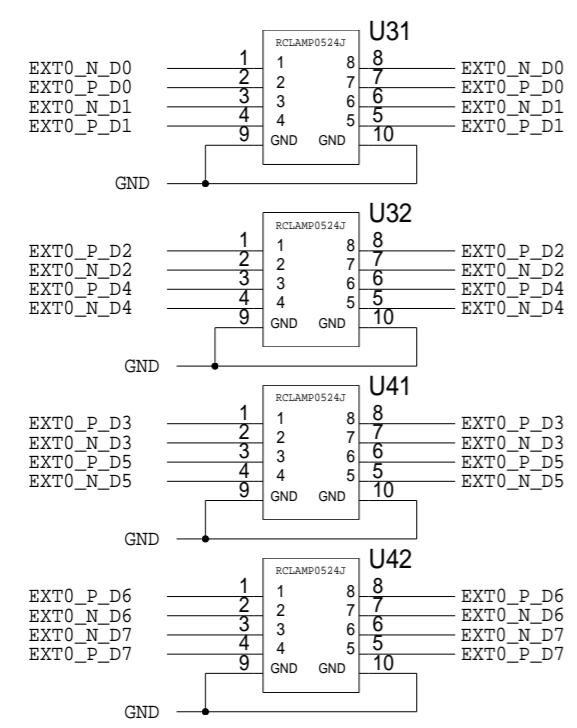
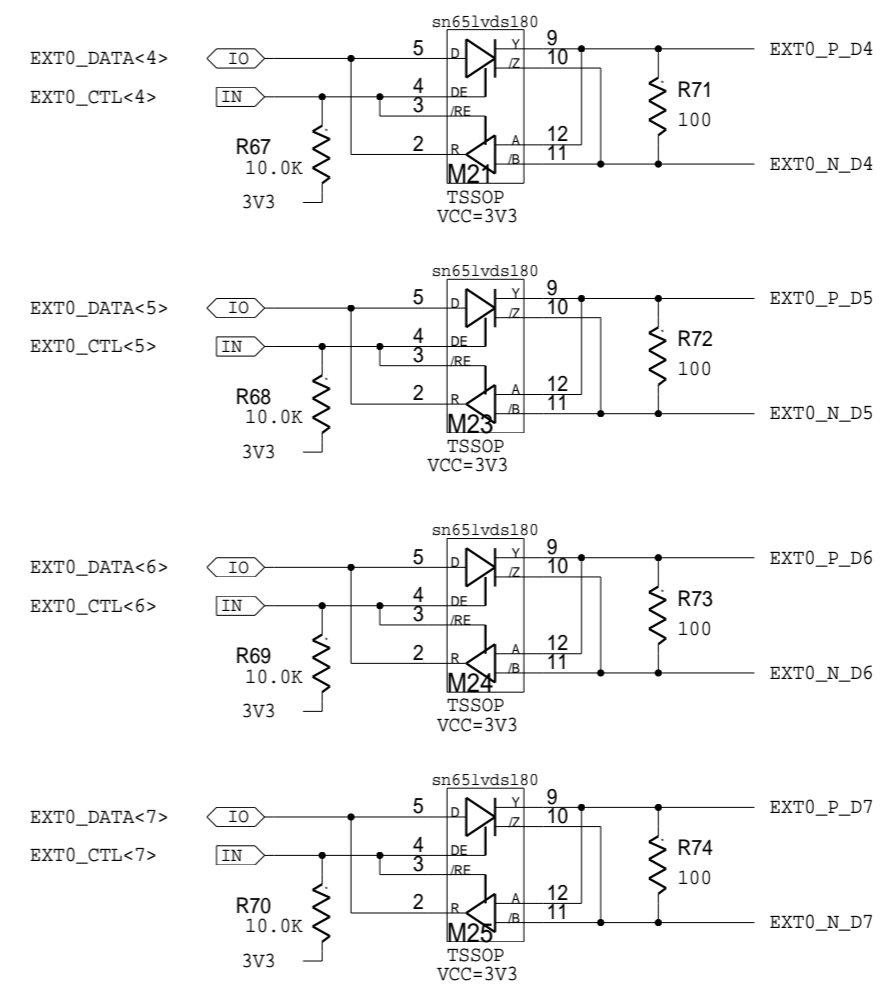
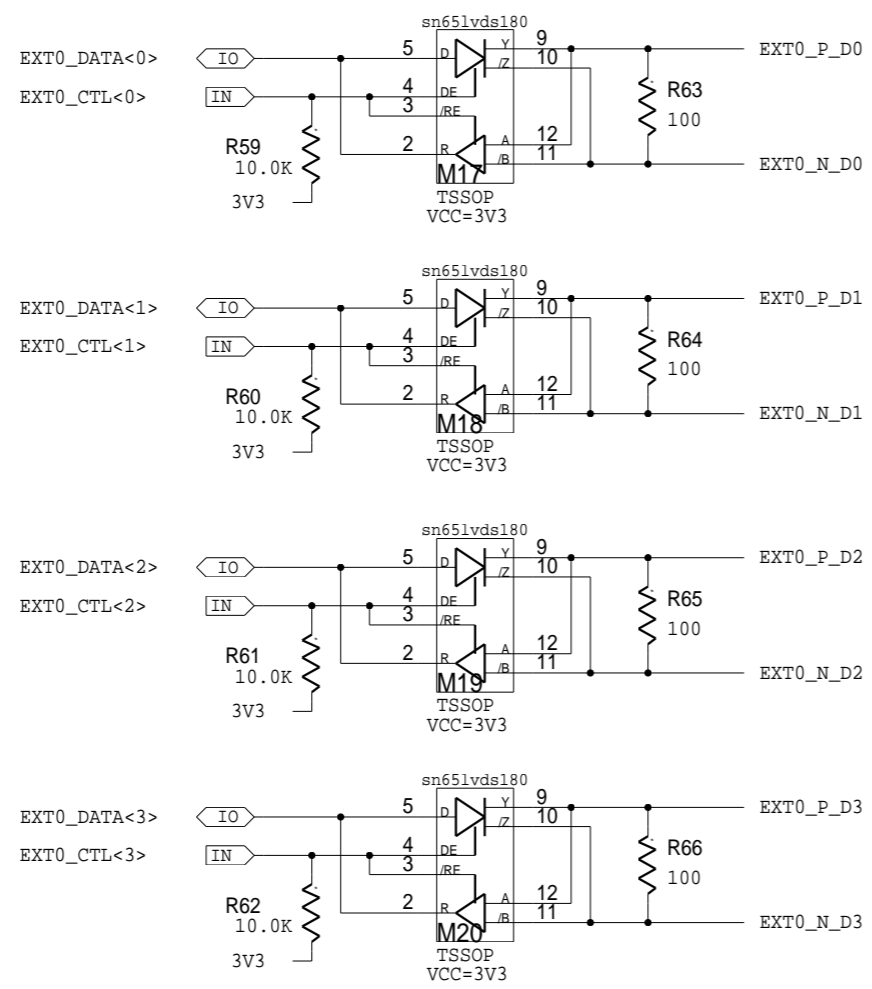
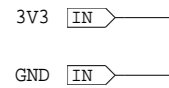

ALL D.N.M.

REF: /CAO-PROJETS/SPB16X/LAGORIO/AUGER/EVAL-UUB/		ETUDE: EVAL-UUB	PAGE: 21/32
53, AVENUE DES MARTYRS 38026 GRENOBLE CEDEX +33 (0)4.76.28.00.00		DESSIN: EL & JB	DATE: 22/03/2016
EXTERNALS CONNECTORS			

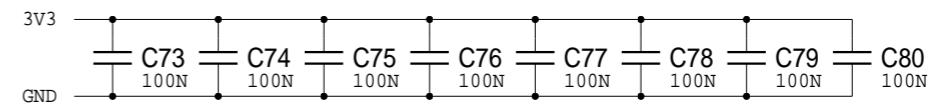
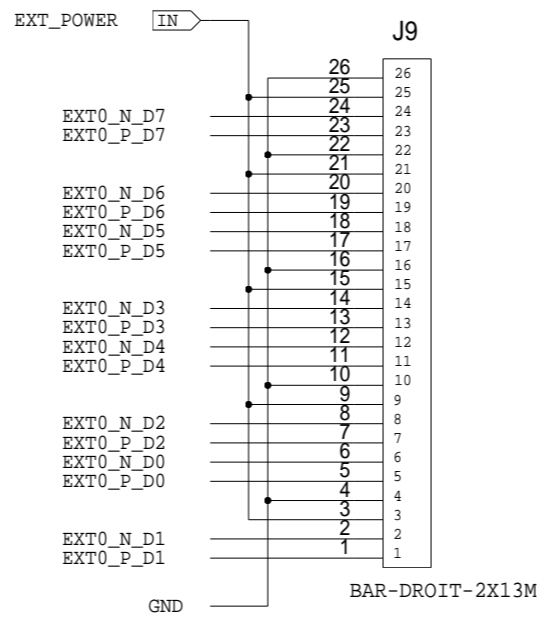
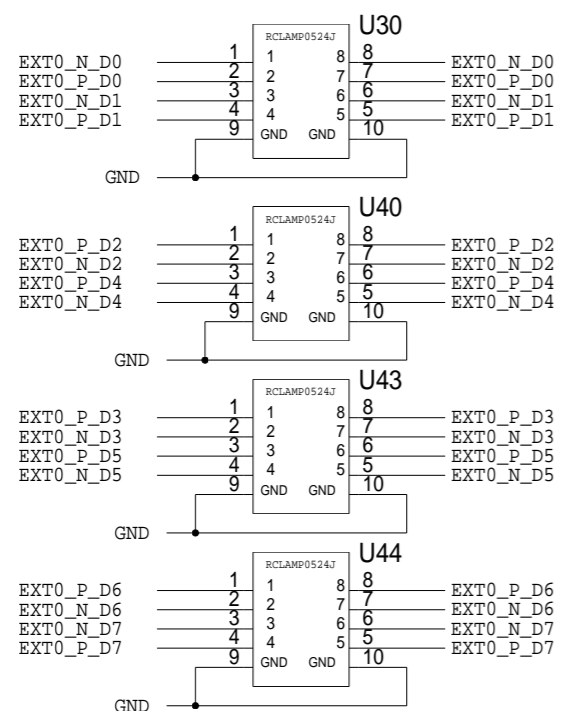
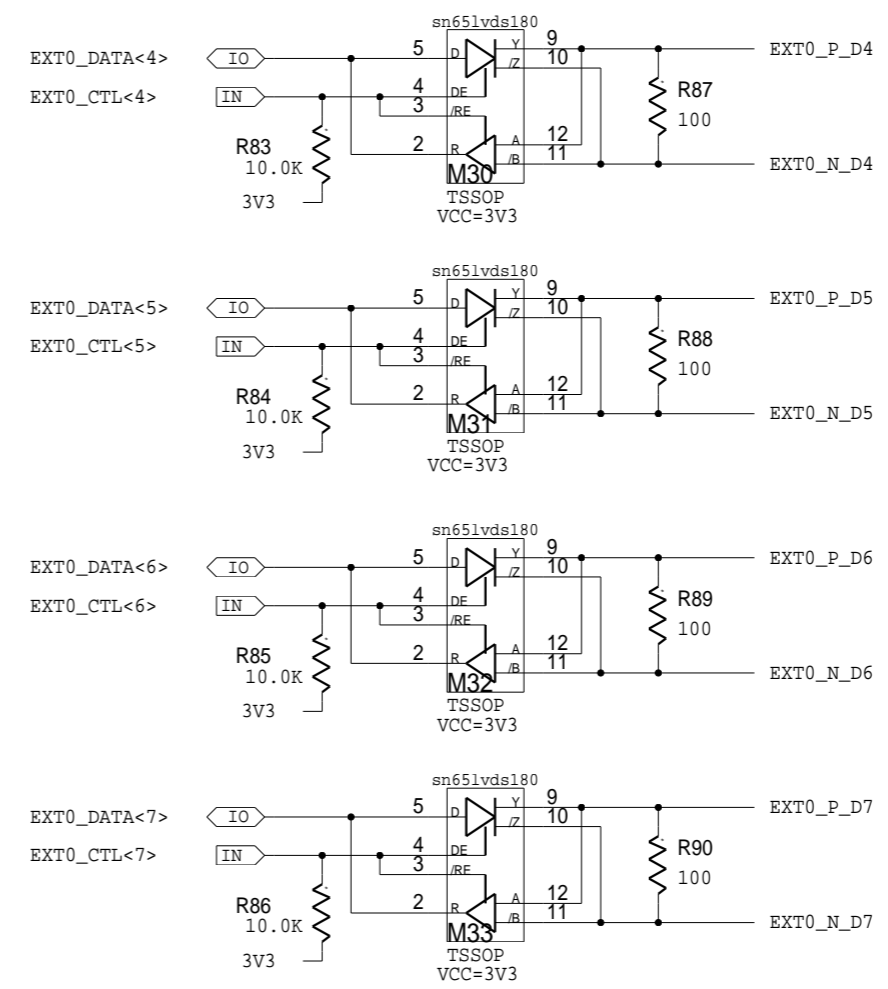
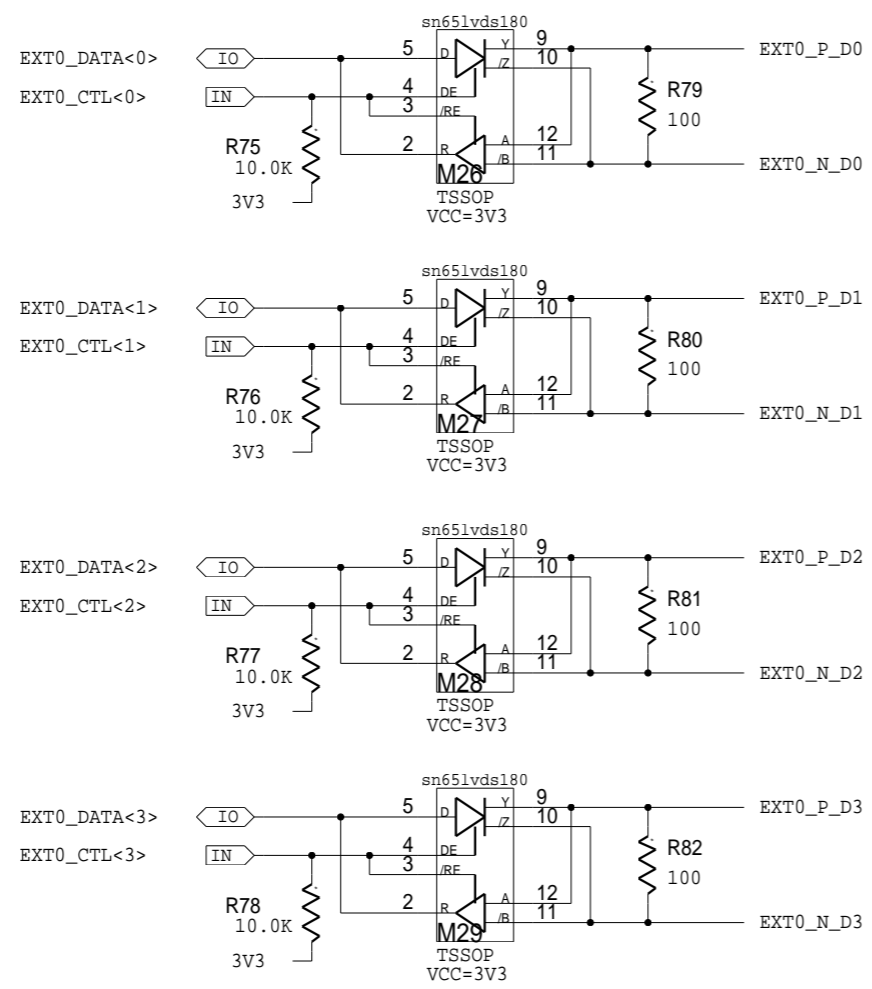
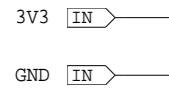

ALL D.N.M.

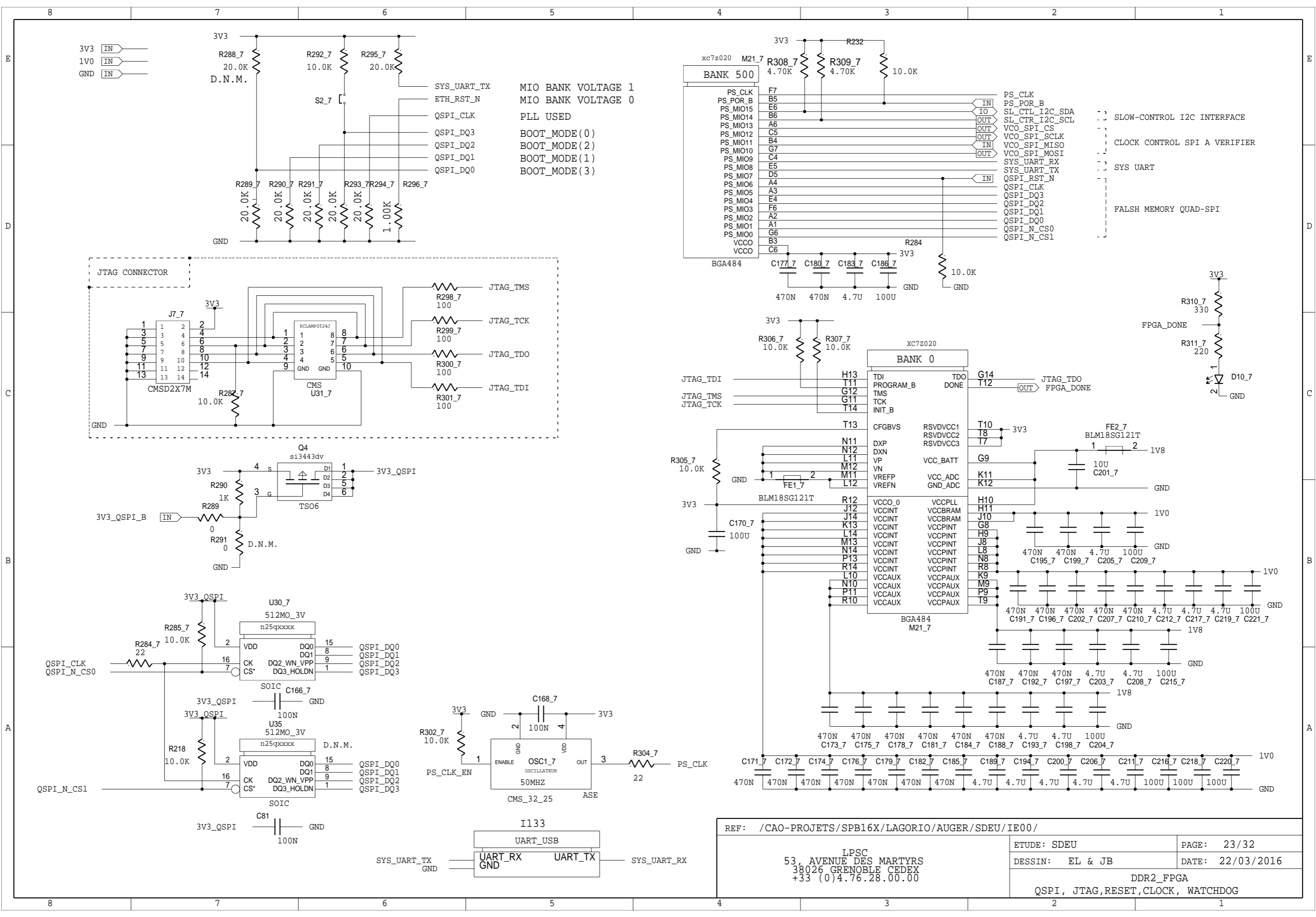

REF: /CAO-PROJETS/SPB16X/LAGORIO/AUGER/SDEU/IE00/	
ETUDE: SDEU	PAGE: 23/32
DESSIN: EL & JB	DATE: 22/03/2016
LPSC 53, AVENUE DES MARTYRS 38026 GRENOBLE CEDEX +33 (0)4.76.28.00.00	
DDR2_FPGA QSPI, JTAG, RESET, CLOCK, WATCHDOG	

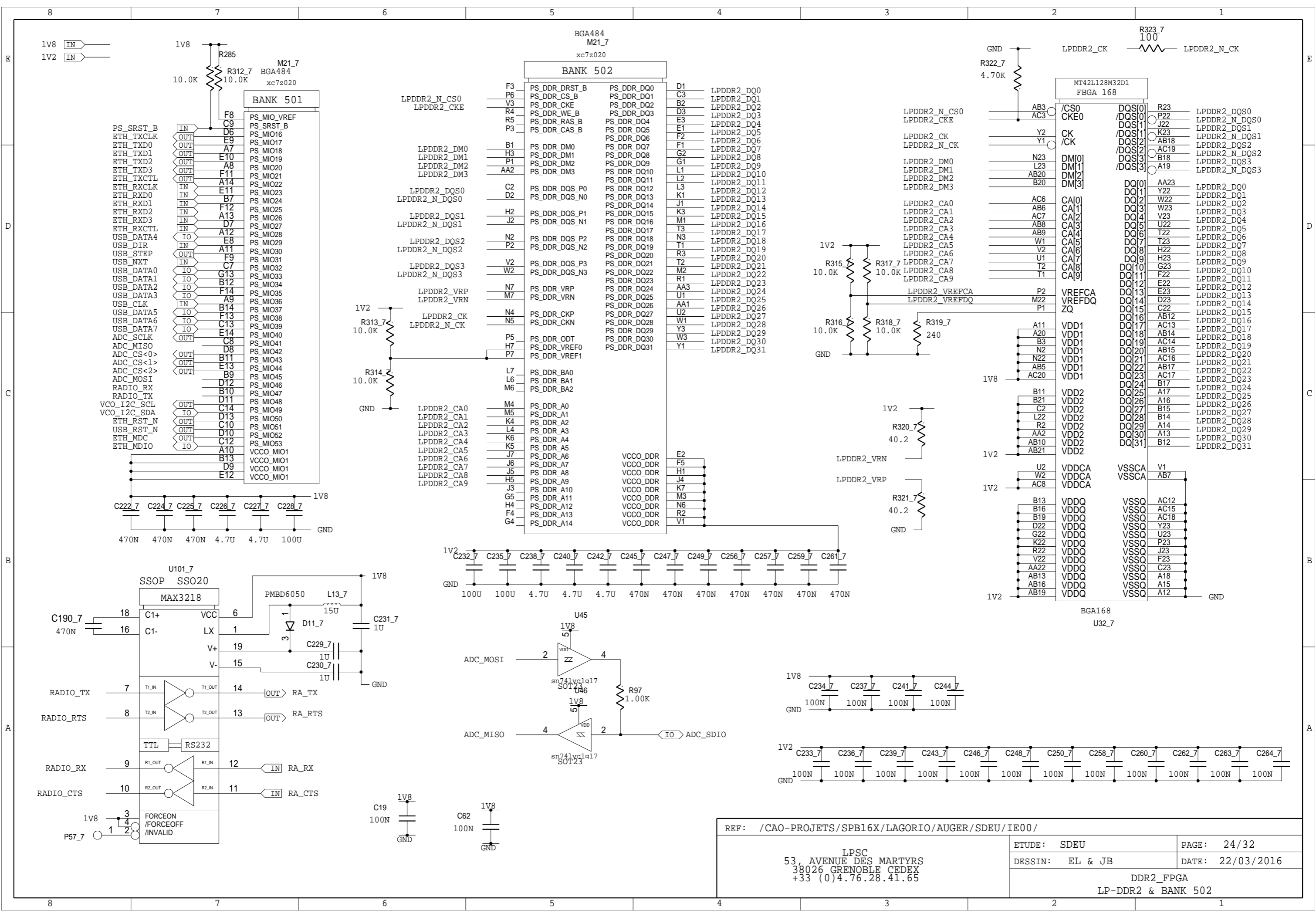

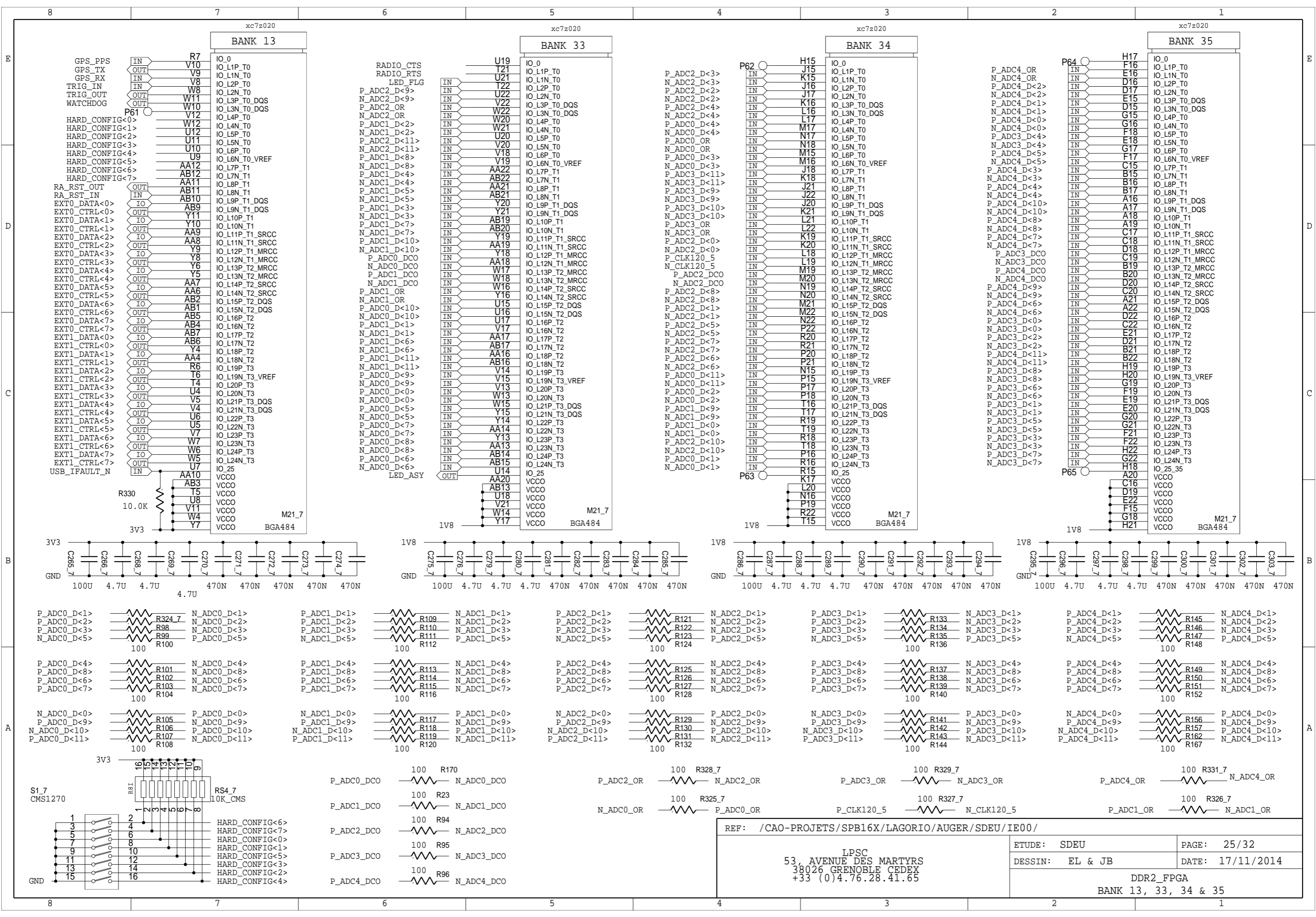

REF: /CAO-PROJETS/SPB16X/LAGORIO/AUGER/SDEU/IE00/

53, AVENUE DES MARTYRS
38026 GRENOBLE CEDEX
+33 (0)4.76.28.41.65

ETUDE: SDEU	PAGE: 25/32
DESSIN: EL & JB	DATE: 17/11/2014
DDR2_FPGA BANK 13, 33, 34 & 35	

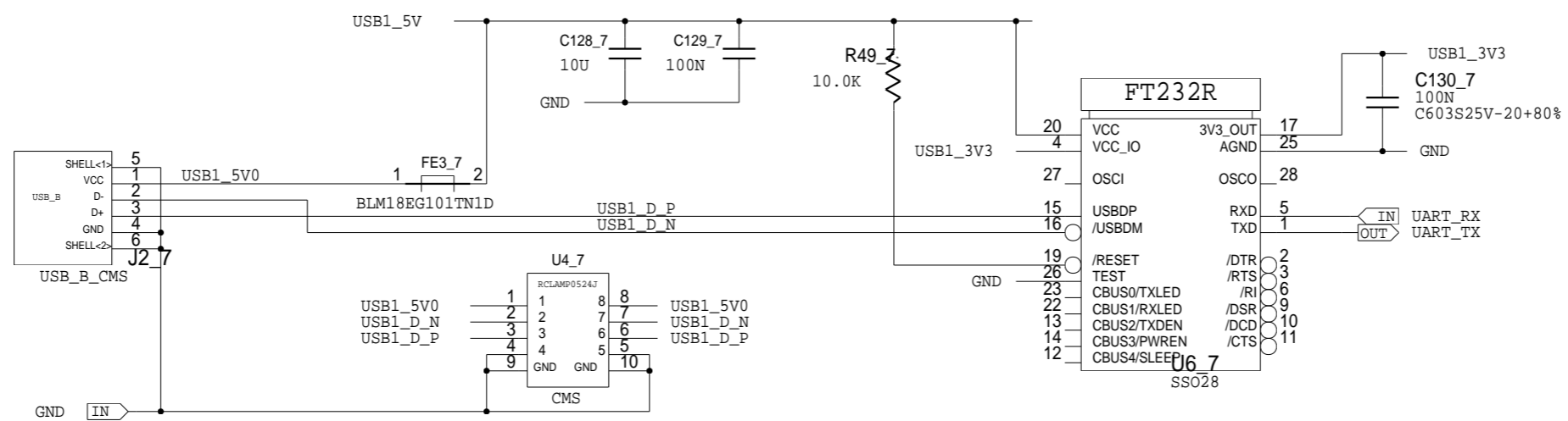

REF: /CAO-PROJETS/SPB16X/LAGORIO/AUGER/SDEU/IE00/		
LPSC 53, AVENUE DES MARTYRS 38026 GRENOBLE CEDEX +33 (0)4.76.28.41.65	ETUDE: SDEU	PAGE: 26/32
	DESSIN: EL & JB	DATE: 17/03/2015
UART / USB		

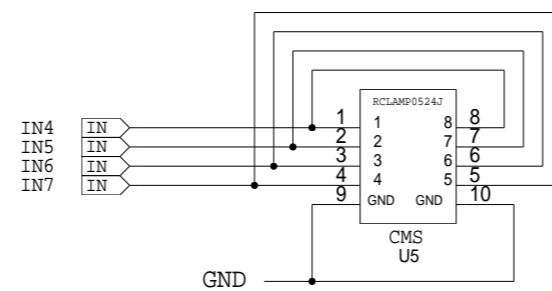
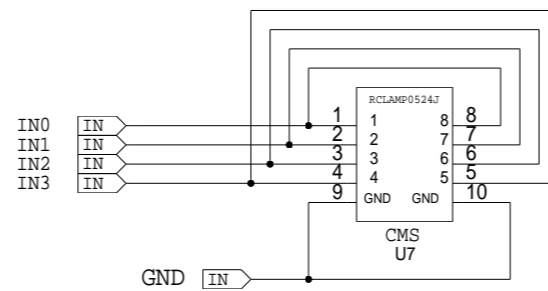

REF: /CAO-PROJETS/SPB16X/LAGORIO/AUGER/SDEU/IE00/

LPSC
53, AVENUE DES MARTYRS
38026 GRENOBLE CEDEX
+33 (0)4.76.28.00.00

ETUDE: SDEU

PAGE: 27/32

DESSIN: EL & JB

DATE: 30/01/2015

ESD 8 PINS PROTECTION
DB15 CONNECTORS

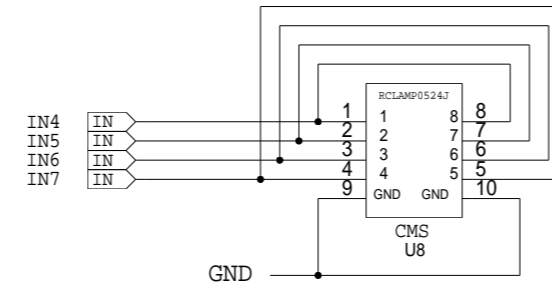
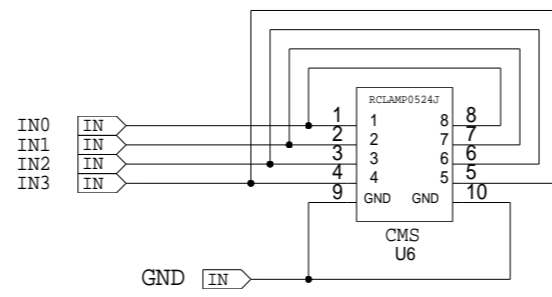

REF: /CAO-PROJETS/SPB16X/LAGORIO/AUGER/SDEU/IE00/	
LPSC 53, AVENUE DES MARTYRS 38026 GRENOBLE CEDEX +33 (0)4.76.28.00.00	ETUDE: SDEU
	DESSIN: EL & JB
PAGE: 28/32	
DATE: 30/01/2015	
ESD 8 PINS PROTECTION DB15 CONNECTORS	

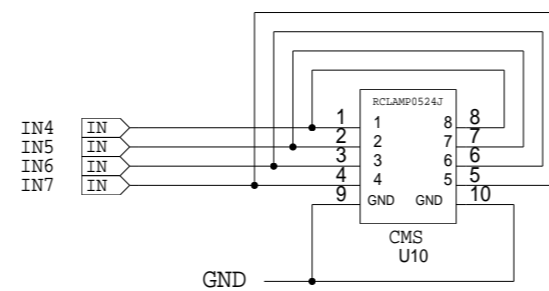
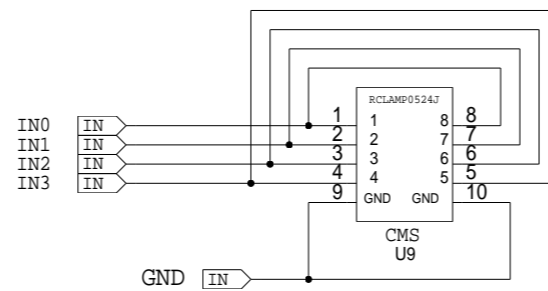

REF: /CAO-PROJETS/SPB16X/LAGORIO/AUGER/SDEU/IE00/

LPSC
53, AVENUE DES MARTYRS
38026 GRENOBLE CEDEX
+33 (0)4.76.28.00.00

ETUDE: SDEU

PAGE: 29/32

DESSIN: EL & JB

DATE: 30/01/2015

ESD 8 PINS PROTECTION
DB15 CONNECTORS

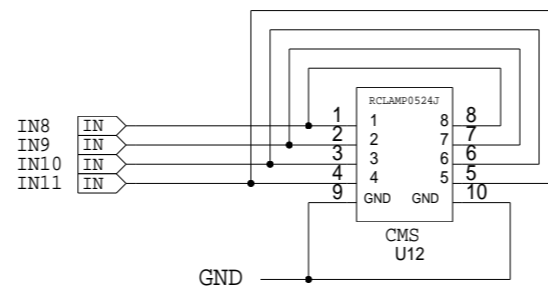
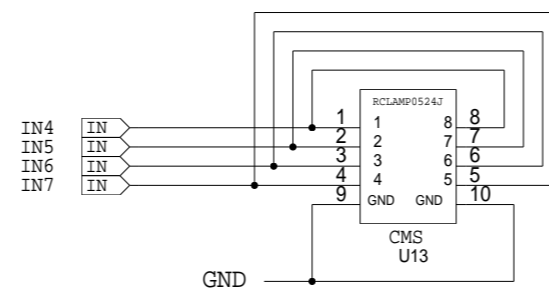
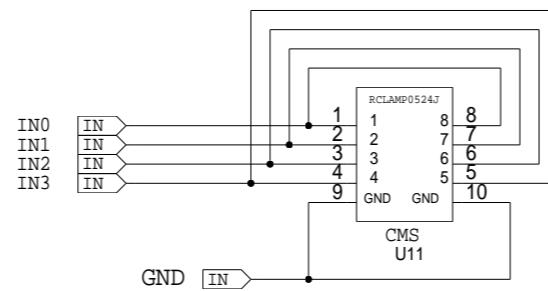

REF: /CAO-PROJETS/SPB16X/LAGORIO/AUGER/SDEU/IE00/		ETUDE: SDEU	PAGE: 30/32
LPSC 53, AVENUE DES MARTYRS 38026 GRENOBLE CEDEX +33 (0)4.76.28.00.00		DESSIN: EL & JB	DATE: 02/07/2014
		ESD 12 PINS PROTECTION DB15 CONNECTORS	

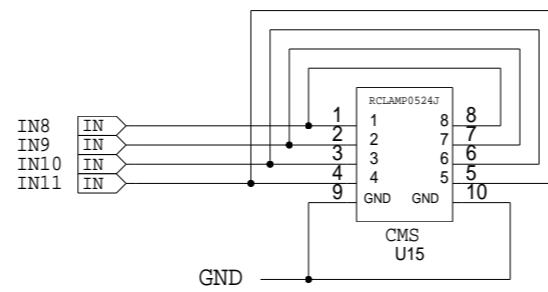
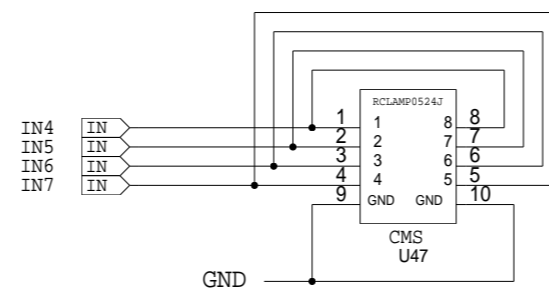
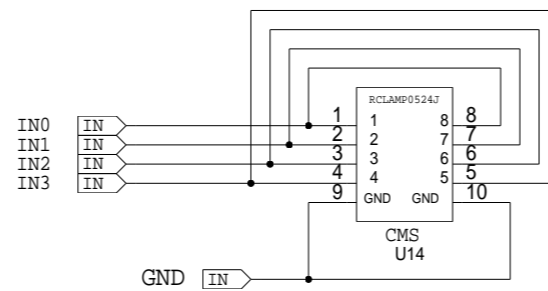

REF: /CAO-PROJETS/SPB16X/LAGORIO/AUGER/SDEU/IE00/

LPSC
53, AVENUE DES MARTYRS
38026 GRENOBLE CEDEX
+33 (0)4.76.28.00.00

ETUDE: SDEU

PAGE: 31/32

DESSIN: EL & JB

DATE: 02/07/2014

ESD 12 PINS PROTECTION
DB15 CONNECTORS

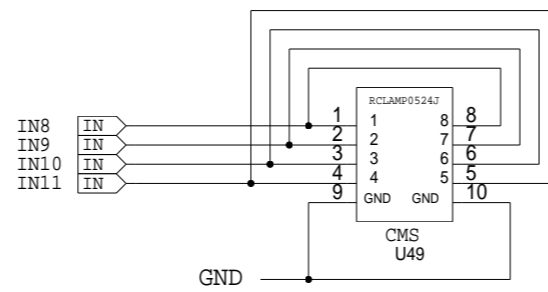
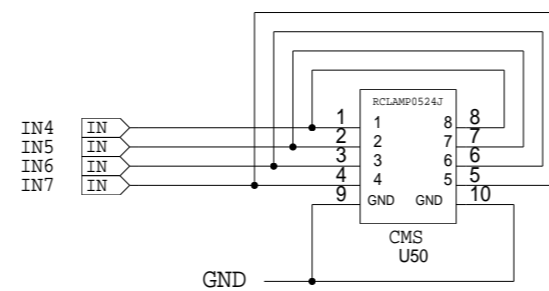
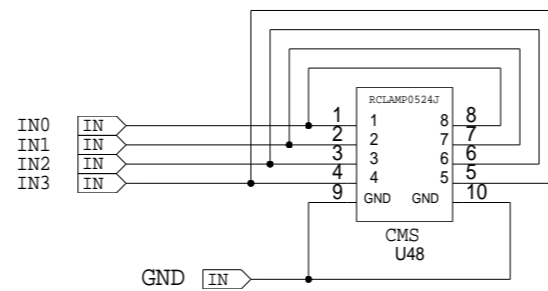

REF: /CAO-PROJETS/SPB16X/LAGORIO/AUGER/SDEU/IE00/

LPSC
53, AVENUE DES MARTYRS
38026 GRENOBLE CEDEX
+33 (0)4.76.28.00.00

ETUDE: SDEU

PAGE: 32/32

DESSIN: EL & JB

DATE: 02/07/2014

ESD 12 PINS PROTECTION
DB15 CONNECTORS