

02	30/01/2026	Y. Magnard	J.-J. Correia	Add items 49;50;58;66;67	M. Chebbo
01	05/12/2025	Y. Magnard	J.-J. Correia	FIRST EDITION	M. Chebbo
INDICE Issue	DATE	AUTEUR Author	VERIFIE PAR Checked by	MODIFICATIONS - observations	APPROUVE PAR approved by
MATERIE material				General tolerances : ISO 2768 mk	MASSE weight 283 KG
TRAITEMENT DE SURFACE surface treatment				Etats de surfaces (surface finish) Ra 3.2 sauf indication	QUANTITE (quantity)
				Filetages (Threads) : 6H	
Institut de Recherche et d'Innovation en Mécatronique et de Génie Mécanique 38400 St MARTIN D'HERES Tel : +33 4 76 51 47 88		CS 40700 F-38058 GRENOBLE CEDEX 9 adresse géographique : Bât OSUG A 414 rue le piscine domaine universitaire 38400 St MARTIN D'HERES Tel : +33 4 76 51 47 88	FORMAT A1 SIZE ECHELLE 1:5 SCALE	TITRE-Title <b>LGS WFS</b> <b>STRUCTURE &amp; TRANSLATION (TRANS) ASSEMBLY</b>	DWG N° E-MAO-PLA-10-02-01-00 IND- Issue FOLIO- Sheet 02 / 1/2

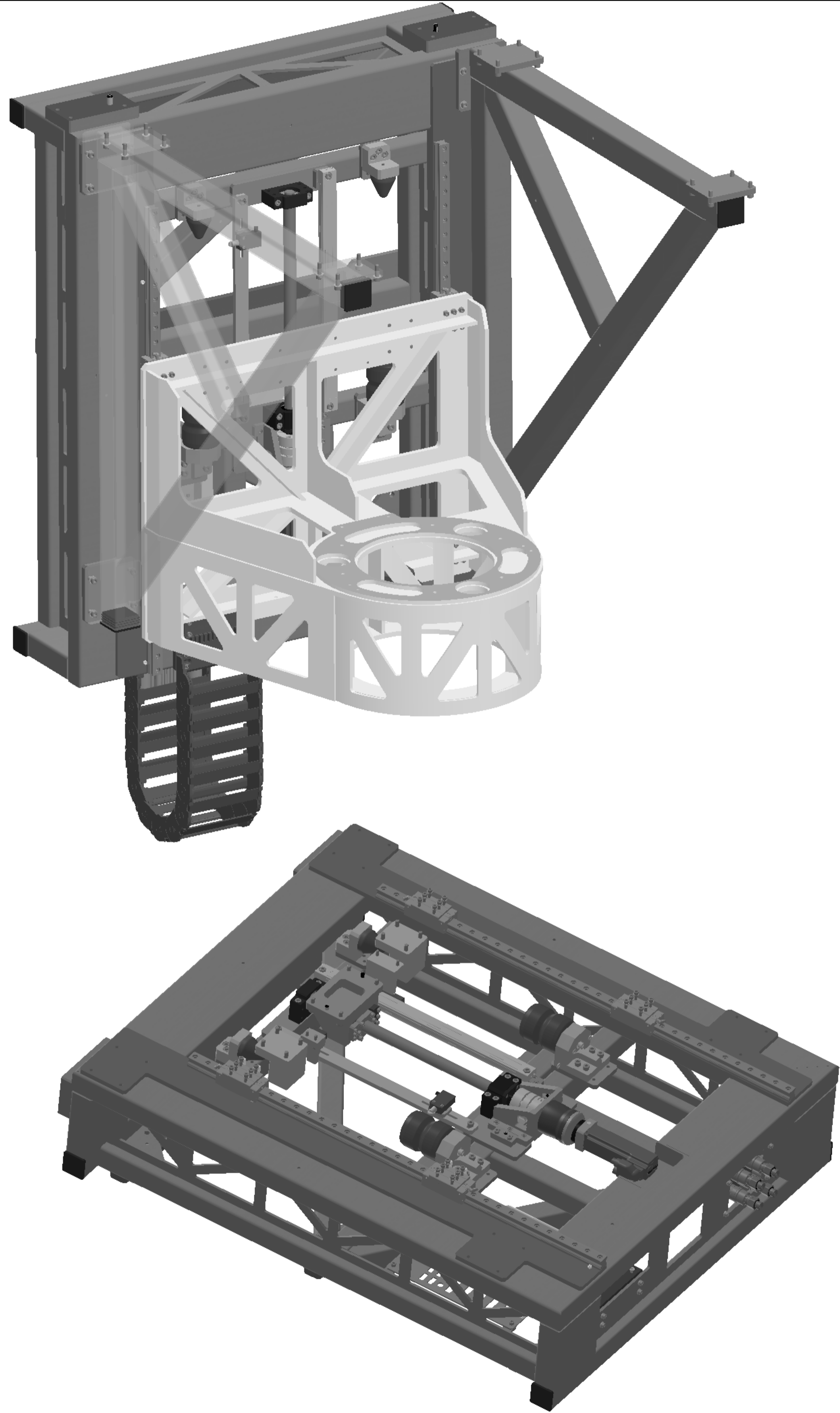

No	NUMERO DE PIECE	Description	Material	masse (g)	observations
1	E-MAO-PLA-10-02-01-02	NUT BRACKET	X2CrNi19-11(304L)	1 2942.09	
2	E-MAO-PLA-10-02-01-06	SWITCH DETECTION PART	EN AW-7075	1 100.88	
3	E-MAO-PLA-10-02-01-07	CHAIN SUPPORT	EN AW-7075	1 423.34	
4	E-MAO-PLA-10-02-01-14	FLOATING NUT FLANGE	CuSn8	1 170.35	
5	E-MAO-PLA-10-02-01-15	FRAME	S235JR (1.0038)	1 129594.19	
6	E-MAO-PLA-10-02-01-17	SCALE HEAD SUPPORT	EN AW-2017A	1 202.22	
7	E-MAO-PLA-10-02-01-19	LIMIT SWITCH SCALE	EN AW-2017A	1 354.2	
8	E-MAO-PLA-10-02-01-22	MOBIL CHAIN SUPPORT	EN AW-7075	1 474.14	
9	E-MAO-PLA-10-02-01-23	MOBIL FRAME	S355 (E36)	1 99938.26	
10	E-MAO-PLA-10-02-01-24	MOTOR BRACKET	X2CrNi19-11(304L)	1 1696.44	
11	E-MAO-PLA-10-02-01-25	NUT CLAMP	EN AW-7075	1 19.29	
12	E-MAO-PLA-10-02-01-26	NUT CLAMP 2	EN AW-7075	1 11.65	
13	E-MAO-PLA-10-02-01-31	SCALE WEDGE	EN AW-2017A	2 48.76	
14	E-MAO-PLA-10-02-01-33	SHOCK ABSORBER SUPPORT	X2CrNi19-11(304L)	2 1801.35	
15	E-MAO-PLA-10-02-01-34	STOP PART	X2CrNi19-11(304L)	2 2017.54	
16	E-MAO-PLA-10-02-01-35	SUPPORT	S235JR (1.0038)	2 23199.76	
17	E-MAO-PLA-10-02-01-36	SWITCH PLATE	EN AW-2017A	2 25.38	
18	E-MAO-PLA-10-02-01-37	UPPER STOP PART	EN AW-7075	2 268.42	
19	E-MAO-PLA-10-02-01-38	CLAMP	X2CrNiMo17-12-2(316L)	2 113.52	
20	E-MAO-PLA-10-02-01-40	COOLING PANEL	EN AW-7075	1 208.67	
21	E-MAO-PLA-10-02-01-41	CONNECTORS PANEL	EN AW-7075	1 517.49	
22	E-MAO-PLA-10-02-01-42	COOLING PANEL SPACER	EN AW-2017A	4 10.83	
23	E-MAO-PLA-10-02-01-43	ROTATION CHAIN SUPPORT	EN AW-7075	1 677.11	
24	E-MAO-PLA-10-02-01-44	RENFORT	Aluminium	2 61.25	
25	E-MAO-PLA-10-02-01-45	E-BOX CROSSBAR	EN AW-7075	2 1376.73	
26	E-MAO-PLA-10-01-01-00	LC145-370		1	HEIDENHAIN
27	E-MAO-PLA-10-01-01-01	LC145-370 (curseur)		1	HEDENHAIN
28	E-MAO-PLA-10-01-03-00	LIMIT SWITCH XCMN 2102L8	Matériau <non spécifié>	2 24.91	SCHNEIDER
29	E-MAO-PLA-10-02-01-01	ANGULAR BEARING HOUSING BK20		1	RODRIGUEZ
30	E-MAO-PLA-10-02-01-03	BALL SCREW - FLI - SFNUR2505LC	100Cr6 (Stub)	1 1881.22	RODRIGUEZ
31	E-MAO-PLA-10-02-01-03-02	BALL NUT SFUR2505	Steel	1 500.00	RODRIGUEZ
32	E-MAO-PLA-10-02-01-04	BUTEE PROGRESSIVE CONIQUE 512501	Matériau <non spécifié>	2 54.89	PAULSTRA
33	E-MAO-PLA-10-02-01-05	CABLE CHAIN 0,896m 2700 09 100 0 260 12E		1	IGUS
34	E-MAO-PLA-10-02-01-08	CIRCLIPS 07330-201200	1.4122 (X39CrMo17-1)	1 1.41	NORELEM
35	E-MAO-PLA-10-02-01-11	CYLINDRICAL PIN 03105-08	100Cr6 (Stub)	3 9.1	NORELEM
36	E-MAO-PLA-10-02-01-12	CYLINDRICAL PIN 03105-12	100Cr6 (Stub)	1 27.94	NORELEM
37	E-MAO-PLA-10-02-01-13	FLEXIBLE COUPLING SCL2-25-D16PFN-16PFN2		1	R+W
38	E-MAO-PLA-10-02-01-16	GRAISSEUR D2-11-02	Steel	3 4.02	MICHAUD CHAILLY
39	E-MAO-PLA-10-02-01-18	KEY DIN 6885 A 5x22	1.4571 (X6CrNiMoTi17-12-2)	1 4.16	NORELEM
40	E-MAO-PLA-10-02-01-20	LOCATING-PIN03105-082	100Cr6 (Stub)	1 8.01	NORELEM
41	E-MAO-PLA-10-02-01-21	LOCATING PIN 03105-122	100Cr6 (Stub)	1 25.02	NORELEM
42	E-MAO-PLA-10-02-01-27	CUSHIONED STOP Evidgom 810666	Matériau <non spécifié>	2 318.39	PAULSTRA
43	E-MAO-PLA-10-02-01-28	PIN 03325-08x20	100Cr6 (Stub)	6 6.13	NORELEM
44	E-MAO-PLA-10-02-01-29	RADIAL BEARING HOUSING BF20		1	RODRIGUEZ
45	E-MAO-PLA-10-02-01-30	RAIL MSR255-2-SS-F0-R980-10-10-H-II	100Cr6 (Stub)	2 3400.00	RODRIGUEZ
47	BECKHOFF-ag3210-np015-mf2-i-lz1-f1	PLANETARY GEAR REDUCER		1	
48	BECKHOFF-AM8012-xx01.stp	BRUSHLESS MOTOR-BRAKE		1	
49	NORELEM-29056-460601540	TUBE CAP		4	
50	NORELEM-29056-450500830	TUBE CAP		4	
51	ISO 4762 M8 x 50 - 28N		cl 10.9	6	Zinguée
52	ISO 4762 M8 x 20 - 20N		cl 10.9	4	Zinguée
53	ISO 4762 M4 x 16 - 16N		cl 10.9	6	Zinguée
54	ISO 4762 M5 x 12 - 12N		cl 10.9	4	Zinguée
55	ISO 4762 M5 x 16 - 16N		cl 10.9	11	Zinguée
56	ISO 4762 M6 x 16 - 16N		cl 10.9	22	Zinguée
57	ISO 4762 M6 x 25 - 25N		cl 10.9	68	Zinguée
58	ISO 4762 M8 x 25 - 25N		cl 10.9	58	Zinguée
59	ISO 4762 M6 x 20 - 20N		cl 10.9	39	Zinguée
60	ISO 10642 - M6 x 16 - 16N		cl 10.9	8	Zinguée
61	ISO 4762 M6 x 12 - 12N		cl 10.9	8	Zinguée
62	ISO 4762 M6 x 10 - 10N		cl 10.9	3	Zinguée
63	ISO 4762 M4 x 6 - 6N		cl 10.9	10	Zinguée
64	ISO 4762 M10 x 100 - 32N		cl 10.9	2	Zinguée
65	ISO 4762 M8 x 16 - 16N		cl 10.9	8	Zinguée
66	Washer ISO 7089 - 8		Stainless steel	32	200HV
67	Washer ISO 7089 - 6		Stainless steel	35	200HV
68	SYAUBLI_CBI09.1152_IA_0_0			4	
69	STAUBLI-CBI09.7152_IA_0_0			4	

02	30/01/2026	Y.Magnard	J.-J. Correia	see sheet 1/1	M.Chebbo
01	05/12/2025	Y.Magnard	J.-J. Correia	FIRST EDITION	M.Chebbo
INDICE	DATE	AUTEUR	VERIFIE PAR	MODIFICATIONS - observations	APPROUVE PAR
issue		Author	Checked by		approved by
MATERIE material				General tolerances : ISO 2768 mk	MASSE weight
TRAITEMENT DE SURFACE surface treatment				Etats de surfaces (surface finish)	KG
				Ra 3.2 sauf indication	QUANTITE (quantity)
				Filetages (Threads) : 6H	
CS 40700 F-38058 GRENOBLE CEDEX 9 adresse géographique : Bât OSUG A 414 rue le piscine domaine universitaire 38400 St MARTIN DHERES Tel : +33 4 76 51 47 88		FORMAT <b>A1</b> SIZE ECHELLE <b>1:5</b> SCALE	TITRE-Title <b>LGS WFS</b> <b>STRUCTURE &amp; TRANSLATION (TRANS)</b> <b>ASSEMBLY</b>		
Ce document ne peut être reproduit divulgué ou utilisé sans autorisation - This document may not be used, reproduced, transmitted without Authorization.					DWG N° E-MAO-PLA-10-02-01-00
					IND- Issue FOLIO- Sheet 02 / 2/2