

AGATA

Advanced Gamma Tracking Array

Project Definition Phase 2

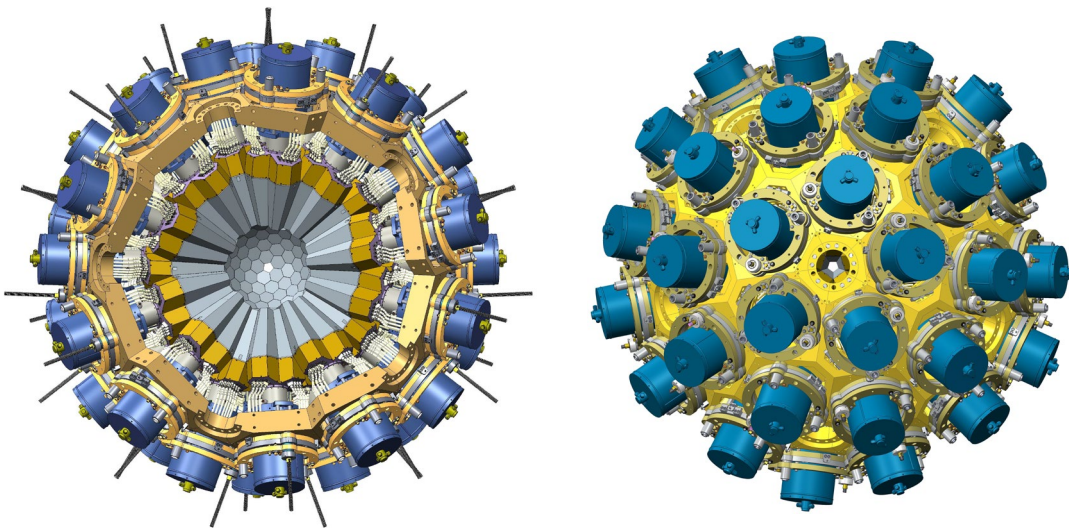

Edited by A. Gadea, B. Million, A. Boston, E. Clement, G. Duchêne, H. Hess, A. Korichi, J. Nyberg, F. Recchia, P. Reiter, J. Simpson

Input provided by the AGATA Management Board, AGATA Teams and other participants:
H. Boston, F. Didierjean, J. Eberth, C. Everett, M. Filliger, K. Green, C. Görgen,
R. Hetzenegger, R. Hirsch, D. Judson, M. Karolak, M. Kebbiri, L. Lewandowski,
L. Ménager, C. Nicolle, G. Richardt, M-H. Sigward, S. Thiel, M. Zielinska, Ch. Bonnin,
L. Charles, J. Collado, L. Gibelin, V. Gonzalez, N. Karkour, X. Lafay, I. Lazarus, D. Linget,
A. Pullia, G. Vinther-Jorgensen, M. Kogimtzis, Ch. Belkhiria, A. Boujrad, F. Saillant,
G. Wittwer, N. Dosme, X. Grave, J. Jacob, E. Legay, G. Lallaire, P. Le Jeannic,
A. Lopez-Martens, O. Stézowski, T. Lauritsen, F. Crespi, J. Dudouet, M. Labiche,
J. Ljungvall, Ph. John, L. Harkness-Brennan, F. Holloway, B. De Canditiis, B. Quintana,
R. Menegazzo, A. Lotodé, T. Joannem, A. Grant, I. Burrows, J.J. Valiente-Dobon,
A. Goasduff.

Index (including links to the sections in the document)

- Introduction to the AGATA Project and to the Phase 2 of the Project	3
- AGATA Phase 2 Project Definition Summary	4
- Detector Module Subsystem	8
Introduction	8
Status of Detector Procurement	9
Construction	10
Costs and Efforts	11
Maintenance Costs Associated to the AGATA Detectors	14
Commitment	15
Further developments	16
- Front End and Pre-Processing Electronics Subsystem	18
Introduction	18
Introduction to the Electronics for the Phase 2 of AGATA	19
Electronics General layout	21
Digitizer: New DIGIOPT12 Board	22
Pre-Processing	23
The Data Transfer Lines	23
The Input Data Motherboard	24
The Control And Processing board (CAP)	25
The Serial Transfer Acquisition Readout over Ethernet (STARE) mezzanine	27
Firmware and Software for the Inspection and Electronics Control	28
Mechanics and Power Supply Unit	32
Global Trigger and Synchronization system and Trigger Processor	32
The SMART Synchronization system and Trigger Processor	33
The Digital Pre-amplifier Development	35
Upgrade of Phase 0 and Phase 1 Electronics	36
Construction	37
Costs, Timescale & Efforts	38
Production and Maintenance Commitment	40
- Pulse Shape Analysis and Characterisation for AGATA Phase 2	42
Introduction	42
Upgrade/Plans for Phase 2	44
Costs & Efforts	46
Commitment	47
- AGATA Data Flow and Data Processing	48
Introduction to the Data Flow Subsystem	48
Data flow software infrastructure	49
Phase 2 Data Flow upgrade & challenges	53
Phase 2 Data Processing upgrade & challenges	57
Data Management and Policy	60
Cost estimates, efforts and schedule	60
Maintenance and Commitment	62
- Detector Infrastructure Subsystems	63
Introduction	63
Upgrade for Phase 2	65

EMC	69
Construction	70
Costs & Efforts of Phase 2	70
Maintenance Commitment	71
- Mechanical Infrastructure Subsystems	72
Introduction	72
Plans for Campaign at LNL (up to 30 ATCs)	72
Costs & Efforts	76
Construction and Commitments	77
AGATA Mechanical and Detector Infrastructure at the LNL (Host Lab responsibility)	77
Introduction	77
Plans for Campaign at LNL (up to 30 ATCs)	77
Costs & efforts for Host Lab	79
- Performance Monitoring, Simulations and Commissioning for the Phase 2 of AGATA	80
Simulations	80
Commitment	82
Commissioning and Performance	82
Commitment	83
- Complementary Instrumentation for AGATA Phase 2	85
Introduction	85
Front End Electronics and Data Flow integration	85
Simulations and Mechanical compatibility of AGATA with the Complementary Instrumentation	87
Commissioning of the AGATA + Complementary Instrumentation setup	88
Example of the NEDA/Neutron Wall + DIAMANT integration in the AGATA setup at GANIL	88
Example of the GRIT integration in its MUGAST version in the AGATA setup at GANIL	90
Beam selection detectors and ancillary integration in the AGATA setup at GSI/FAIR	91
Costs & Efforts	92
Commitment	93
- Annex I: AGATA Phase 2 summary tables for the tasks, effort and Institutions involved in the 10y period	94
Summary of the Tasks and Institutions involved	94
Efforts for AGATA activities included in the Project Definition over the 10y period	96
- Annex II: AGATA Phase 2 summary tables for the upgrade of AGATA to 135 detectors (3π)	97
- Annex III: AGATA Phase 2 summary table for additional costs for the completion of the AGATA array from 135 to 180 detectors (4π)	102

Introduction to the AGATA Project and to the Phase 2 of the Project

The AGATA array, is the European forefront instrument based on semiconductor Germanium detectors, for high-resolution γ -ray spectroscopy. It is used in the nuclear research facilities operating presently in Europe and will be especially important for the experimental conditions expected at the future facilities for intense radioactive ion beams as well as for high-intensity stable ion beams.

The European experimental γ -ray spectroscopy community has a long-standing tradition of coordinated efforts to build large scale high-energy resolution arrays. Since the early nineties, the community has worked together to build instruments with the highest possible sensitivity, e.g. the escape-suppressed spectrometer EUROBALL (1995-2004). The escape-suppression technique provides excellent peak-to-total (signal to background) ratios but limits the solid angle covered by the Ge detectors, thus limiting the sensitivity of the arrays.

AGATA is the result of the early European Commission financed initiative, the TMR network ‘Development of γ -ray tracking detectors’, with the participation of most of the present AGATA partner countries. Between 1996 and 2001 it encouraged the development of the highly segmented position sensitive Germanium detector technology.

The inception of the Ge position sensitive detectors technology has opened the possibility to build arrays of detectors based on the γ -ray tracking concept, providing an unprecedented level of sensitivity and efficiency. Only two arrays with such technology are being built in the world, the European implementation of the tracking array is realized in the AGATA project. The second one, as well under construction in the U.S., is the GRETA array.

AGATA is being built in a collaborative effort of more than 40 institutes in 12 countries. The conceptual design of AGATA foresees a 4π array with 60 triple clusters summing up to 180 Ge encapsulated detectors. Along the way to the final configuration, smaller sub arrays of AGATA have been implemented, first as a prove of concept for a tracking array at INFN-LNL and later, still at INFN-LNL, to prove the potential of AGATA in different experimental conditions as well as to profit from the scientific possibilities, with the maximum of the characteristics provided by the early AGATA implementations.

Since 2012 AGATA sub-arrays have been installed at the FAIR/NUSTAR-precursor PRESPEC set-up, placed at the focal plane of the FRS Fragment Separator in GSI, where experiments with in-flight highly relativistic exotic beams were performed, and at GANIL and SPIRAL where experiments with high-intensity stable beams and reaccelerated ISOL radioactive beams will be performed till mid 2021.

The present document updates the AGATA TDR (https://www.agata.org/sites/default/files/reports/TDR_EUJRA.pdf), describing how the collaboration intends to progress on the construction of AGATA until the full completion, as recommended in the “NuPECC Long Range Plan 2017” document.

AGATA Phase 2 Project Definition Summary

Phase 2 of AGATA (2021-2030) aims to progress on the construction toward the completion of the array. In this section, the concepts and most relevant upgrades are summarized. They are described in detail in the main text of the Project Definition for the Phase 2 of AGATA.

The guidelines for the construction of AGATA are:

- Sustainable growth of the AGATA subsystems from a configuration of 60 detectors resulting at the completion of Phase 1 to the full configuration of 180 Detectors,
- Improving mobility and compatibility for the Hosting labs: FAIR/NUSTAR, GANIL/SPIRAL, LNL/SPES, HIE-ISOLDE, JYFL,
- Achieving full Tracking Performance and optimizing the Position sensitivity,
- Improving performance of subsystems: Detectors, FEBEE, Data Flow, Infrastructure.

The first step on this new phase of AGATA will be the upgrade of the subsystems for the 60 detectors already existing. This is necessary for some of the subsystems as some parts belong to the early AGATA Demonstrator Phase, and were produced about 15 years ago.

To achieve the goal of increasing the number of available detectors and simultaneously operating the existing detectors, the high reliability of the cryostats and HPGe detectors will be further improved. On the detector side a new encapsulation technique for the HPGe crystals was developed and will be used for the future systems. This new encapsulation is completely compatible with the previous capsule but with a reusable detector housing. The new detector housing will both reduce the detector-repair costs significantly and the repair time.

To improve the reliability and to reduce the maintenance work of the cryostats, further modifications are foreseen to be established in the newly ordered cryostats. In the new AGATA Triple Cryostats the getter material will be mounted in an accessible housing mounted on the cooling finger. This facilitates the annealing of the getter material without exposing the whole cryostat as well as the detectors to thermal stress. Additionally, a more robust feedthrough is implemented to drastically decrease the vulnerability of the cryostat during a vacuum breakdown after an accidental warm up. Future developments will focus on the reduction of the maintenance costs and workload with a simultaneous increase of the high reliability of the detector systems. To handle the degrading of the energy resolution due to neutron damage of the HPGe detectors a reliable annealing procedure, preferable at higher temperature, has to be developed. A long-term goal will be the replacement of the actual n-type HPGe detector material by a p-type detector material. The development of an electrical (mechanical) cooling of the HPGe detectors could replace the cooling with liquid nitrogen.

The ultimate development of the AGATA Triple Cryostats could be the implementation of the cold VLSI (ASIC or else) fast-reset pre-amplifiers with warm digitizer in close proximity and highly-integrated digital pre-amplifiers, nevertheless, this is presently beyond the state-of-the-art of the different technologies involved. All these future developments will be based on the existing modular concept with a simultaneous compatibility to older generations of detectors and cryostats.

The key electronics goals for phase 2 of the project are to maintain the capabilities developed in the previous versions of the AGATA electronics, while reducing the complexity of the multiple optical connections, reducing the customized hardware parts and simplifying the interfacing of the customized parts with the rest of the system. To achieve these goals, the sampling Digitizers will be located, together with the pre-processing at the very front end. This has been possible thanks to the increasing processing capabilities of the state-of-the-art FPGAs. The data transfer will be performed using the standard Ethernet protocol. This decision, taken together with the Working Groups in charge of the Data Flow and Pulse Shape Analysis, will allow the dispatch of sample data to different processors in the PSA Farm.

The electronics hardware will make extended use of commercial “System on Module” (SoM) boards, simplifying the design and maintenance of the parts.

It is foreseen to maintain and improve the synchronization and trigger capabilities of the electronics, possibly with the use of newly developed subsystems in synergy with other large-scale instruments and laboratories.

The electronics system will have inspection, monitoring and debugging capabilities beyond what is presently available. This will facilitate researchers and engineers working with the setup to solve possible issues more efficiently and to check the data treatment by the pre-processing and triggering sub-systems.

Finally, the use of cost-competitive large-processing-capability FPGAs will open possibilities on improving the data pre-processing (MWD, Base-Line restoration, etc) if resulting in a larger Effective Number of Bits (ENOB) for the final data.

The physics goals of the AGATA phase 2 campaign will require improvements to the performance, both capability and computational, of the AGATA PSA algorithm. PSA is the most computationally intensive aspect of the AGATA computing system, and thus drives the processor requirements. However, PSA is also a parallel process carried out at the individual crystal level, allowing a relatively straightforward architecture with multiple independent processing nodes.

In order to improve the capability performance of the PSA a number of improvements are proposed. Firstly, an investigation of the dominant factors limiting the performance of the calculated basis will be performed. Necessary changes would then be made to the signal basis used by the PSA algorithm to identify interaction locations. The implementation of the existing AGS algorithm will be optimised for performance throughput. This work will include the addition of the export of PSA position uncertainties from the AGS algorithm to the Gamma-ray tracking algorithm.

The PSA algorithm will then be upgraded to include the handling of multiple interactions in a segment. The performance of this algorithm will be evaluated and

implemented for phase 2. The use of other (non AGS) PSA algorithms is being explored for future implementation. The focus is on the possibilities available using machine learning and will build on initial work that has started within the collaboration.

The data flow structure will continue to use the architecture of DCOD/NARVAL. With the DCOD version, memory access and network transmission are managed by the POSIX Memory Handler (PMH) and Common Transport Layer (CTL) which are no more embedded in the DCOD/NARVAL processes. These features are well suited for the full AGATA array as it will provide the required flexibility, modularity and robustness. With today's algorithms and with future faster processors, one may be able to easily process the PSA at 10 kHz/crystal with one or two Anode per crystal. Furthermore, with the capability to balance the CPU load, different PSA algorithms can be used depending on the event complexity enabling to improve the performance. Moreover, as the new electronics will base the readout on ethernet, the CPU can be distributed over High Performance Computer farms (HPC). In this case the ratio of 1 processing node per crystal is not anymore necessary thanks to load balancing and new technologies. Beside the advantages of the new electronics and data acquisition scheme in terms of infrastructure and performance, the software trigger, already under development, represents a major contribution of the Data Flow Working Group.

The present AGATA Detector Support System (DSS) planned for 20 ATCs needs to be enlarged in view of a setup with 30, 45 or up to 60 ATCs. Some items are obsolete and built with now discontinued components. Important upgrades are in progress. These developments will use modern components to build (backward compatible) modules for an array of 30 ATCs with the possibility to easily extend the production for a full configuration of 60 ATCs. The extension of the array will require the production of new LVPS crates and modules that will take into account the reduced power consumption of the electronics which is presently being developed, an upgraded LN₂ detector filling system, the purchase and installation of a new HV system, and the production and installation of additional sets of cables, like those developed and produced for the Phase1 of the project. The EMC will be tested and improved when needed. The implementation of an array with 20 ATCs, as given in the Phase 1 MoU, will use the first upgrade of crates and modules as part of the full array infrastructure.

The mechanical support structure of the AGATA array is being renewed so that it can hold the 2π array (30 ATCs) in the different Host Laboratories. This mechanical project foresees the possibility to be extended for a full 4π array (60 ATCs). The future AGATA main frame needs to hold the 2π array, to rotate it $\pm 90^\circ$ for detector loading procedure and to translate for access to the target area. It will be optimized for compatibility between the different Host Labs. Moreover, it will easily be enlarged to the 4π array support. The project is based on an axle shaft holding the 2π honeycomb structure with the possibility to rotate it. Such a structure will allow to open or translate the array either along the beamline or perpendicular to it.

For the tracking and data analysis for Phase 2, a straight forward improvement can be expected if the PSA is able to provide errors on the position and energy of the interactions. New developments using hybrid algorithms (Forward + Backward tracking) and machine learning technology offer opportunities for further improvements. The data analysis package is performing very well and additional developments are foreseen in order to enable analysis of higher fold coincidences as we do today with the 3D and 4D cubes. Furthermore, with the advent of γ -ray tracking detector arrays, it should be possible to measure entry distributions and the quasi-continuum of γ rays with orders of magnitude better accuracy than with Euroball or Gammasphere.

There are ideas to use tracking algorithms as a constraint to better identify interaction points in a crystal. There are promising opportunities offered by machine learning techniques (deep neural networks). The current software solutions to replay the data on a single computer (such as femul emulator, GammaWare or NARVAL standalone version) will be continuously updated. More advanced solutions adapted to the computing infrastructures based on cloud technologies and heterogeneous hardware (GPU/FPGA) for example, will be implemented where appropriate.

All future set-ups at different Host Laboratories, coupled to different complementary instrumentation, will require commissioning experiments.

Monitoring of performance in the long term is important and will be crucial to quantify the radiation damage to each of the crystals and, therefore, to decide on the maintenance work.

Methods for extracting angular distributions and correlations will be developed and refined. The variety of experimental conditions and complementary instrumentation will be included in the AGATA simulations.

This will be done implementing new event generators and specific realistic geometries. Accuracy of the simulation will be improved as soon as more information will be provided from the characterization of the crystals, in particular dead layers and passive materials will be refined to obtain the most accurate reproduction of the detector efficiency.

Detector Module Subsystem

Introduction

The AGATA Triple Cluster (ATC) detector consists of three asymmetric, 36-fold segmented, hexagonal shaped, encapsulated, tapered high-purity germanium (HPGe) detectors. The cluster detector comprises 111 high-resolution spectroscopy channels from the core contacts and the 36 segments of each crystal. Three capsules with sealed HPGe detectors are operated in one vacuum cryostat. The detectors are operated at liquid nitrogen temperature. Presently this is achieved using a liquid nitrogen dewar. For all 111 energy signals, cold input stages of the pre-amplifiers (FET with their feedback circuits operated under vacuum at LN2 temperature level) are used for lowest noise contribution and highest bandwidth. The use of a separate cooling ensures a minimal electronic noise contribution of the first input stages. The cold input stages are connected by feedthroughs into the warm part of the cryostat, i.e. not cryogenically cooled part, and to the warm stages of the pre-amplifiers. To monitor the temperature and vacuum properties, two PT100 resistive sensors are mounted inside the cryostat, one close to the germanium capsule and one close to the dewar. Additionally, information on the filling level and consumption of liquid nitrogen is monitored through a capacitance measurement between a metallic cylindrical tube inside the dewar and the inner wall of the cryostat. The fill level dependent capacitance is converted by a C/V-transducer into a DC voltage signal which provides a direct monitoring of the nitrogen level inside the dewar.

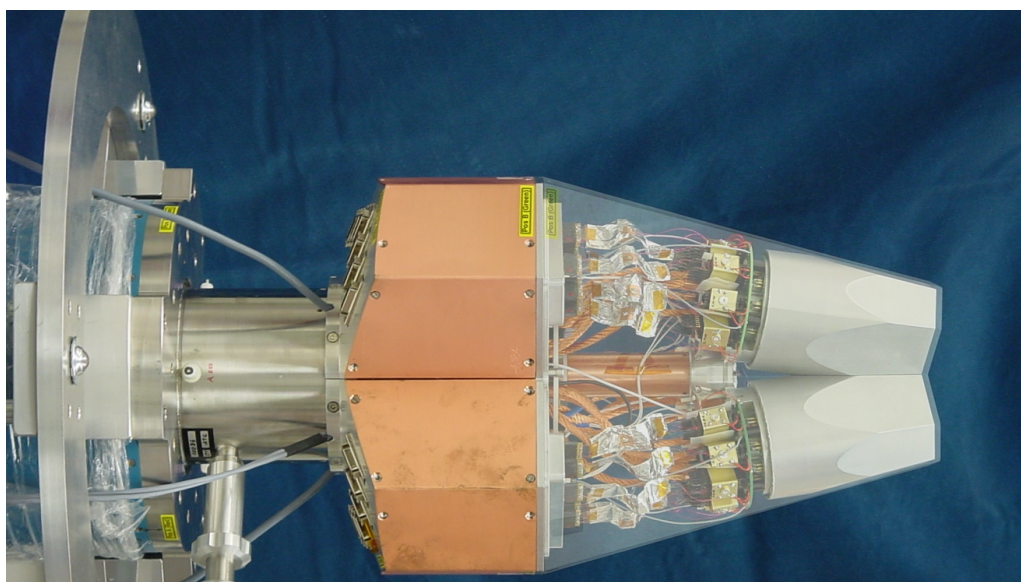

AGATA triple cluster showing the cooled stages of pre-amplifiers

The AGATA triple clusters (ATCs) require a major part of the capital investment within the AGATA project. The ATCs comprise mainly the investment for the germanium capsules and the cryostats. Additionally, expenses are caused by the operational costs, repairs and maintenance.

The complexity of the ATC requires a seamless collaboration between the AGATA detector group and all other AGATA working groups within the project. This is crucial to achieve the best reachable performance of the spectrometer.

Status of Detector Procurement

The situation of the encapsulated HPGe detectors is summarized in the following table. In total, 3 symmetric capsules and 48 asymmetric capsules (A-type, B-Type and C-type) were delivered.

Funding of 6 more HPGe detectors is approved. The orders of these 6 detectors is ongoing (status April, 2020). Seventeen sets of detectors, are property of the following different institutions of the AGATA collaboration.

	Owner		Owner		Owner
S001	IKP	S002	GSI	S003	TUM
A001	GANIL	B001	INFN Padova	C001	INFN Padova
A002	INFN	B002	IN2P3	C002	CEA Saclay
A003	Liverpool	B003	Liverpool	C003	Liverpool
A004	Ankara	B004	Ankara	C004	Ankara
A005	Sweden	B005	Sweden	C005	Sweden
A006	INFN Padova	B006	INFN Padova	C006	INFN Legnaro
A007	INFN Milano	B007	IKP Cologne	C007	IKP Cologne
A008	IKP Cologne	B008	IKP Cologne	C008	Liverpool
A009	Liverpool	B009	Liverpool	C009	CEA Saclay
A010	INFN Milano	B010	INFN Milano	C010	IFIC Valencia
A011	IN2P3	B011	INFN Legnaro	C011	IN2P3
A012	CEA Saclay	B012	IN2P3	C012	IN2P3
A013	TU Darmstadt	B013	CEA Saclay	C013	IFIC Valencia
A014	IKP Cologne	B014	INFN-Milano	C014	INFN Milano
A015	IN2P3	B015	TU Darmstadt	C015	TU Darmstadt
A016	Finland	B016	IKP Cologne	C016	IKP Cologne

For the 2019 physics campaign 44 detectors were employed in fourteen AGATA Triple Clusters and one AGATA Double Cluster.

Construction

The AGATA detector group will take care of the constant increase of the available number of the AGATA Triple Cryostats in order to reach the maximum efficiency for the experimental campaigns. The modular design of the ATC, the basic detector configuration and the proven cryostat technology will be employed also for the future phase of extension. A high reliability and low failure rate of the ATCs is mandatory and reflected in low maintenance effort for the spectrometer. Future developments focus on these aspects and new technical solutions are part of selected research and development projects of the detector working group.

Cryostat:

The AGATA cryostats will be manufactured in the next phase with the existing modular conception. To improve the reliability of the cryostats, modifications are foreseen to be implemented in the newly ordered cryostats.

For the 222 signal cables and approx. 30 grounding connections, new cable feedthroughs were developed which are compatible with the existing feedthroughs. These feedthroughs consist of gold-plated contact pins in insulators of aluminium-oxide ceramic. The gold-plated pins are sintered in one connector with a Cu-Ag-alloy and seven connectors are integrated by electron welding in one titanium-housing. One of these new feedthroughs is needed for the cabling of one HPGe detector. The feedthroughs are decreasing drastically the vulnerability for vacuum breakdowns after warm up of the whole system. In total, twelve out of 13 existing ATCs, have been upgraded with these new feedthroughs. The new technology will be used for all future ATCs.

The vacuum quality, in both the pressure and its rest gas composition, is improved by using an efficient and powerful vacuum getter material. Up to now the getter material was integrated in the dewar and had to be annealed with the cryostat hardware. For this operation the HPGe detectors were removed. The procedure is time consuming and all material inside the cryostats is exposed to thermal stress. To cope with this situation, the getter material will be mounted in a flexible housing on the cooling finger in the new triple cryostats. This getter material container can be easily accessed and dismantled without removing all three HPGe detectors. The getter material will be annealed outside the cryostat, reducing the maintenance time. The first new getter containers were tested and are already installed inside three ATCs (ATC10, ATC13 and ATC14).

In future, all existing cryostats will be modified and the getter material will be integrated in the container at the cooling finger. To equip the older ATCs with new getter container, some effort has to be invested for replacement of the getter within the dewar. This is foreseen to be part of future major maintenance and repair action of the ATC cryostats.

Detectors:

The highly segmented HPGe detectors are made of n-type HPGe material. Each crystal is encapsulated into a hermetically sealed aluminium canister. This facilitates the handling of the detectors during mounting and maintenance of the cryostats. The disadvantage of this encapsulation technology is the destructive opening of the capsule by the detector manufacturer in case of detector failure inside the detector capsule. HPGe crystal repair by the manufacturer is time-consuming and expensive. Therefore, a reusable detector housing was developed in cooperation between the IKP Cologne detector working group and the detector manufacturer MIRION. The new technology was successfully tested and employed for the production of detectors A013, A014, B015, B016, C015 and C016. The geometrical size and all other HPGe detector specifications are completely compatible with the previous HPGe detectors and its capsule. The new HPGe detector technology is operational since 2016 and will be used for all future AGATA HPGe detector.

Pre-amplifier (Electronics):

The Core and segment pre-amplifiers are part of the cryostat and delivered by the manufacturer of the cryostats. In principle, no changes in the pre-amplifiers are foreseen for the next phase (otherwise, see Detector Technology R&D activities section). Potential difficulties due to obsolete electronic components and maintenance of the preamps are anticipated and new design releases for the pre-amplifier will be provided by the electronics groups at IKP Cologne and INFN Milano. For example, the cooled analogue electronics was modified due to the obsolete field effect transistor FET BF862 which was no longer produced by manufacturers.

All these developments will be performed in close cooperation between the infrastructure group and the electronic group. The fundamental premise is to keep all future developments compatible with the existing ATC design.

Costs and Efforts

With the increasing number of ATCs, respectively detectors, also the efforts necessary for maintenance will grow. To cope with this task in the future, the workload will be distributed among four existing AGATA detector laboratories at University of Cologne, University of Liverpool, Irfu/CEA Saclay, IPHC Strasbourg. For this task, detector experts are available at all AGATA detector laboratories. A reasonable amount of spare ATCs and individual detectors is foreseen to maintain the continuous operation of the spectrometer.

The procurement costs for the detectors and cryostats is given in the following sections. The information includes the number of detectors and cryostats expected to be ordered each year, the cost for a single detector or cryostat, the total cost for the detectors and

for the cryostats, the total cost when applying the reduction discussed below and the annual expenditure for the full hardware.

The detector manufacturer Mirion Technologies (Canberra, France) has submitted a draft quotation for long-term supply of AGATA encapsulated HPGe detectors. The reference price for the quotation is the single encapsulated HPGe detector price as communicated to the AGATA collaboration in 2020: 206500 €. The reference price is updated annually on the basis of the French Labour cost index. In case the index varies by more than $\pm 2.5\%$ over a year, the change in price will be capped at the value of $\pm 2.5\%$. Our collected information, over more than 10 years of detector procurement, has shown that an increase of 1.5% per year has been applied in average.

The Mirion manufacturer's quotation includes a discount regulation for procurement of several future AGATA HPGe detectors per year. The "cost reduction" represents the savings in labour and material cost for detectors manufactured in quantity. The discount will depend on the numbers of HPGe detectors (N_{det}) ordered by the AGATA collaboration in a given year. The reduced unit price will benefit from a linearly progressing discount of $1 - (3\% * (N_{\text{det}} - 1))$ on the total price for procurement of up to 12 detectors per year corresponding to: no discount for the purchase of only one detector per year (for $N_{\text{det}} = 1$ reference price will be 206500 €) up to a maximum discount of 33% for the procurement of $N_{\text{det}} = 12$ or more in the same year. Thus, the price for N_{det} detectors is therefore given by $(206500\text{€} * N_{\text{det}}) * (1 - (3\% * (N_{\text{det}} - 1)))$, since the reduction is applied to all the detector units price. This calculation does not include the cost adjustment following the French Labour cost index as discussed above.

Regarding the cryostat costs, the current provider (CTT) has quoted 115 k€ as reference price for 2019. A discount of 5 % for a simultaneous purchase of two cryostats, 7.5 % discount for a simultaneous purchase of three cryostats and 10 % discount for a simultaneous purchase of four cryostats is offered.

Cost to Upgrade from AGATA Phase 1 to 135 Encapsulated Detectors (3 π)

To reach the goal of 135 detectors (3 π) until 2030, the AGATA community has to order a total of 75 detectors and 25 cryostats corresponding to an average of 7.5 detectors and 2.5 Triple Cryostats per year for the next 10 years. All costs are given in k€ without taxes.

The total cost for 75 detectors and 25 cryostats, based on the 2020 reference for the detector and on the 2019 quoted price for the cryostat, including an average increase of 1.5% per year would be **20128.6 k€**. These will be the funds needed for procurement plan without discount, as was in fact the case for Phase 1.

Considering the new quotation, negotiated by the Detector Module Team with Mirion Technologies, including an average inflation, observed during the last 10 years, of 1.5% per year and including the reduction corresponding to the ordered number of detector and cryostats, the total cost will be **16622.0 k€**. The funding scheme over the 10 years

is summarized in Table 1. The total costs could be further reduced accumulating detectors and cryostats purchasing in a reduced time period.

In their quotation, Mirion Technologies, included a maximum increase of the costs of 2.5% per year. With this condition a maximum cost of **17405.5 k€** for the encapsulated detectors and the cryostats will be expected.

Table 1) funding scheme for the 75 encapsulated detectors and 25 cryostats considering the expected increase (1.5% per year) and the discount offered by Mirion Technologies and CTT. Total expected cost over 10 years is 16622.0 k€

Year	2021	2022	2023	2024	2025	2026	2027	2028	2029	2030
number of detectors	7	8	7	8	7	8	7	8	7	8
price/detector	211.2	214.4	217.6	220.9	224.2	227.5	231.0	234.4	237.9	241.5
Total detector costs	1478.6	1715.1	1523.2	1767.0	1569.3	1820.4	1616.7	1875.4	1665.6	1932.1
Reduced detector costs	1214.5	1357.7	1251.2	1398.7	1289.0	1441.0	1327.9	1484.6	1368.1	1529.5
number of cryostats	3	2	3	2	3	2	3	2	3	2
price/cryostat	118.5	120.3	122.1	123.9	125.7	127.6	129.5	131.5	133.5	135.5
Total cryostat costs	355.4	240.5	366.2	247.8	377.2	255.3	388.6	263.0	400.4	270.9
Reduced cryostat costs	328.8	228.5	338.7	235.4	348.9	242.5	359.5	249.8	370.4	257.4
Total Costs	1543.2	1586.2	1589.9	1634.1	1637.9	1683.5	1687.4	1734.4	1738.4	1786.8

Costs to Upgrade from AGATA Phase 1 to 180 Encapsulated Detectors (4 π)

To reach the goal of 180 detectors (4 π) within 2030, the AGATA community has to order a total of 120 detectors and 40 cryostats resulting in 12 detectors and 4 Triple Cryostats per year for the next 10 years.

The **total** cost for 120 detectors and 40 cryostats, based on the 2020 reference for the detector and on the 2019 quoted prices for the cryostat, including an average inflation of 1.5% per year would be **32199.8 k€**. These will be the funds needed for procurement plan without discount, as was in fact the case for Phase 1.

Considering the new quotation negotiated by the Detector Module Team with Mirion Technologies, including an average inflation, observed during the last 10 years, of 1.5% per year and including the reduction corresponding to the ordered number of detectors and cryostats, a total cost of **22809.3 k€** for the encapsulated detectors and the cryostats is to be expected.

In their quotation, Mirion Technologies, including a maximum increase of the costs of 2.5% per year. With this condition a maximum cost of **23850.9 k€** for the encapsulated detectors and the cryostats will be expected.

Table 2) funding scheme for the procurement of 120 encapsulated detectors and 40 cryostats considering the expected inflation (1.5% per year) and the discount offered by Mirion Technologies and CTT. Total expected cost over 10 years is 22809,3 k€.

Year	2021	2022	2023	2024	2025	2026	2027	2028	2029	2030
number of detectors	12	12	12	12	12	12	12	12	12	12
price/detector	211.2	214.4	217.6	220.9	224.2	227.5	231.0	234.4	237.9	241.5
Total detector costs	2534.7	2572.7	2611.3	2650.4	2690.2	2730.5	2771.5	2813.1	2855.3	2898.1
Reduced detector costs	1704.7	1730.2	1756.2	1782.5	1809.3	1836.4	1863.9	1891.9	1920.3	1949.1
number of cryostats	4	4	4	4	4	4	4	4	4	4
price/cryostat	118.5	120.3	122.1	123.9	125.7	127.6	129.5	131.5	133.5	135.5
Total cryostat costs	473.9	481	488.2	495.6	502.5	510.5	518.2	526	533.8	541.9
Reduced cryostat costs	426.5	432.9	439.4	446	452.7	459.5	466.4	473.4	480.5	487.7
Total Costs	2131.2	2163.1	2195.6	2228.5	2261.9	2295.9	2330.3	2365.3	2400.7	2436.8

Maintenance Costs Associated to the AGATA Detectors

Maintaining the AGATA Triple Cryostats and detectors implies division of the repair into several tasks, from technical inspection to diagnostic and repair. The first steps should be done in the host laboratories by the local staff with help, if needed, from the highly trained detector experts. If possible, simple repair work will be done on site, and only if it is inevitable the systems will be transported to the AGATA detector laboratories to be repaired. With the increasing number of detectors, also the running costs and needed efforts will increase. To cope with this task all detector labs have to be trained to be able to repair the systems without practical guide. The estimate running cost is given in the table below. It considers a detector failure rate of 7.5%, a cost of 50 k€ per detector repair and maintenance costs of 1.5 k€ per cryostat and year.

The maintenance costs for the two possible upgrades to 3π or 4π are given in the following tables.

Table 3) Detector and cryostat maintenance cost for the upgrade to 3π

Number of Detectors installed	60	66	75	81	90	96	105	111	120	126	135
Estimated number of detectors with failures	5	5	6	6	7	8	8	9	9	10	11
Detector repair cost*	209.1	212.3	215.5	218.7	277.5	337.9	343.0	406.2	412.3	478.2	546.1
Cryostat maintenance	78,7	87,9	101,4	111,1	125,3	135,7	150,6	161,6	177,3	189,0	205,5
Total	287.8	300.2	316.8	329.8	402.8	473.6	493.6	567.8	589.6	667.2	751.6

* the warranty of the detectors has been taken into consideration while calculating the maintenance costs

Table 4) Detector and cryostat maintenance cost for the upgrade to 4π

Number of Detectors installed	60	72	84	96	108	120	132	144	156	168	180
Estimated number of detectors with failures	5	6	7	8	9	9	10	11	12	13	14
Detector repair cost*	209.1	212.3	269.3	328.0	388.4	394.3	457.4	522.2	589.0	657.6	728.1
Cryostat maintenance	78.7	95.9	113.5	131.7	150.4	169.6	189.4	209.7	230.5	252.0	274.0
Total	287.8	308.1	382.9	459.7	538.8	563.9	646.7	731.9	819.5	909.6	1002.2

* the warranty of the detectors has been taken into consideration while calculating the maintenance costs

Commitment

With the growing number of Ge-detectors and Triple Cryostats the needed man-hours will increase also. To take the new procured Ge-detectors and Cryostats in operation a workload up to 370h per ATC is needed. This workload consists of the Customer Acceptance Test (CAT) after the detector delivery by Mirion or Factory Acceptance Test (FAT), the Acceptance Tests of the AGATA Triple cryostat after the assembly of the new ATC by CTT, transport to the research facility and commissioning on site. To provide the maximum possible number of detectors for the physics campaign a steady maintenance of the detectors and cryostats is indispensable. Therefore, a continues maintenance procedure is established. To improve the vacuum properties each ATC must be annealed every 3 years, this means 15 to 20 ATCs (for a $3\pi - 4\pi$ configuration) have to be refurbished per year. Before the AGATA-spectrometer is moving to a new research facility or every 5 or 6 years a major inspection with corresponding repairs and upgrades for the ATCs is planned. The workload for this repair activity can increase from 100h/ATC up to 460h/ATC if the Ge-detectors have to be annealed in consequence of neutron damage.

To master these challenges in the future, the workload will be distributed among the research facilities which are hosting the AGATA-spectrometer and the four existing AGATA detector laboratories at University of Cologne, University of Liverpool, Irfu/CEA Saclay and IPHC Strasbourg.

Efforts required for the construction and maintenance of the Detector Modules

Activity	ETF/year	Description
Taking in operation the new ATCs	0.5	Needed until 2030
Maintenance of the Ge-detectors and ATCs	2,5	Workload increases with increasing number of detectors
Maintenance at the host facility	0,5	Technical inspection for diagnostics and small repairs
Development cryostat	0,5	Development of new cryostats, improvement of the reliability of the existing systems
Development Ge-detectors	0,5	Development of p-type detectors, new methods of passivation and dotation

Further developments

Detectors and Maintenance Costs

The Detector Module Working Group has committed since the beginning of the AGATA project to reduce the costs of the encapsulated detectors and their maintenance. Actions continue in this direction, a second provider is being searched actively and an encapsulated detector prototype is under production at a possible second provider. It is expected that the presence of competition in the provider market helps to contain or reduce the encapsulated detector costs.

Moreover, the recently developed new encapsulation technique has largely helped to reduce the repairing costs from about 93 k€ to 50 k€. Nowadays we are attempting to have the annealing performed while vacuum pumping the capsule. This might help to reduce the failure rate of the encapsulated detectors during the annealing process.

Detector Technology R&D activities

Neutron damage is a major issue for highly segmented n-type HPGe detectors. Fast neutrons create negatively charged lattice defects which are traps for holes. All segment signals are affected by this issue leading to left tail on the energy peaks and a decreasing energy resolution. To approach this issue a reliable annealing procedure will be developed in cooperation with the detector manufacturer. For this a modified HPGe detector capsule is requested allowing a higher annealing temperature (approx. 150 °C) with respect to the existing one (102 °C). The estimated costs for this is 150 k€.

A long-term goal will be the replacement of the actual n-type HPGe detector material by a p-type detector. Therefore, new methods for the doping and passivation of the p-type Germanium detector have to be developed. These developments are pursued within the ENSAR2 JRA PSeGe. The estimated costs for development of new doping and passivation methods 300 k€ and for developing the segmented p-type detector to production series maturity: 650k€

Cryostat:

High-Purity Germanium detectors require cooling to LN2 temperature to operate as gamma-ray detectors. Operating costs, availability, and the hazardous nature of the liquid nitrogen limits the practicality of the Germanium detectors.

Recent advances in electrical (mechanical) cooling technologies have the potential to replace the inconvenient liquid nitrogen cooling. The major problems of standard electrical coolers are the limited cooling power and degraded performance of the detectors due to vibrations. To adapt the electrical cooling to the AGATA Triple Cryostat further developments are needed to reduce the mechanical vibration and to obtain the needed cooling power. The estimated costs for development of an electrical cooler is 150 k€ and the costs to adapt the electrical cooler to the AGATA Triple Cryostat is estimated to be 200 k€.

Electronics:

Long term developments of the electronic group, replacing the Pre-Amplifier and the DIGIOPT12 board, e.g. using cold VLSI (more likely ASIC) fast reset pre-amplifiers with warm digitizer in close proximity and highly integrated digital pre-amplifiers, necessitate in a first step the development of a test cryostat to test the performance of the new electronics. The estimated costs for the development of a test cryostat with this new technology is 80 k€. The estimated costs for the integration of the new electronics in a largely modified AGATA Triple cryostat is 200 k€.

Front End and Pre-Processing Electronics Subsystem

Introduction

The AGATA efficiency and peak-to-total performance figures are achieved by using Pulse Shape Analysis (PSA) and gamma-ray tracking techniques, requiring the array working in Position Sensitive mode. In order to apply the PSA and tracking algorithms, it is necessary to digitize synchronously the 36 (segment) +1 (core) charge pulse and induced signals of each crystal at a 100 Msp/s rate. The core signal is split in the core pre-amplifier providing two amplification gains. The large counting-rate limit in the AGATA specifications requires a fast trigger in order to reduce data transfer and storage of the signal traces. Moreover, the energy associated to the charge signals, has to be determined on-line by using an MWD algorithm.

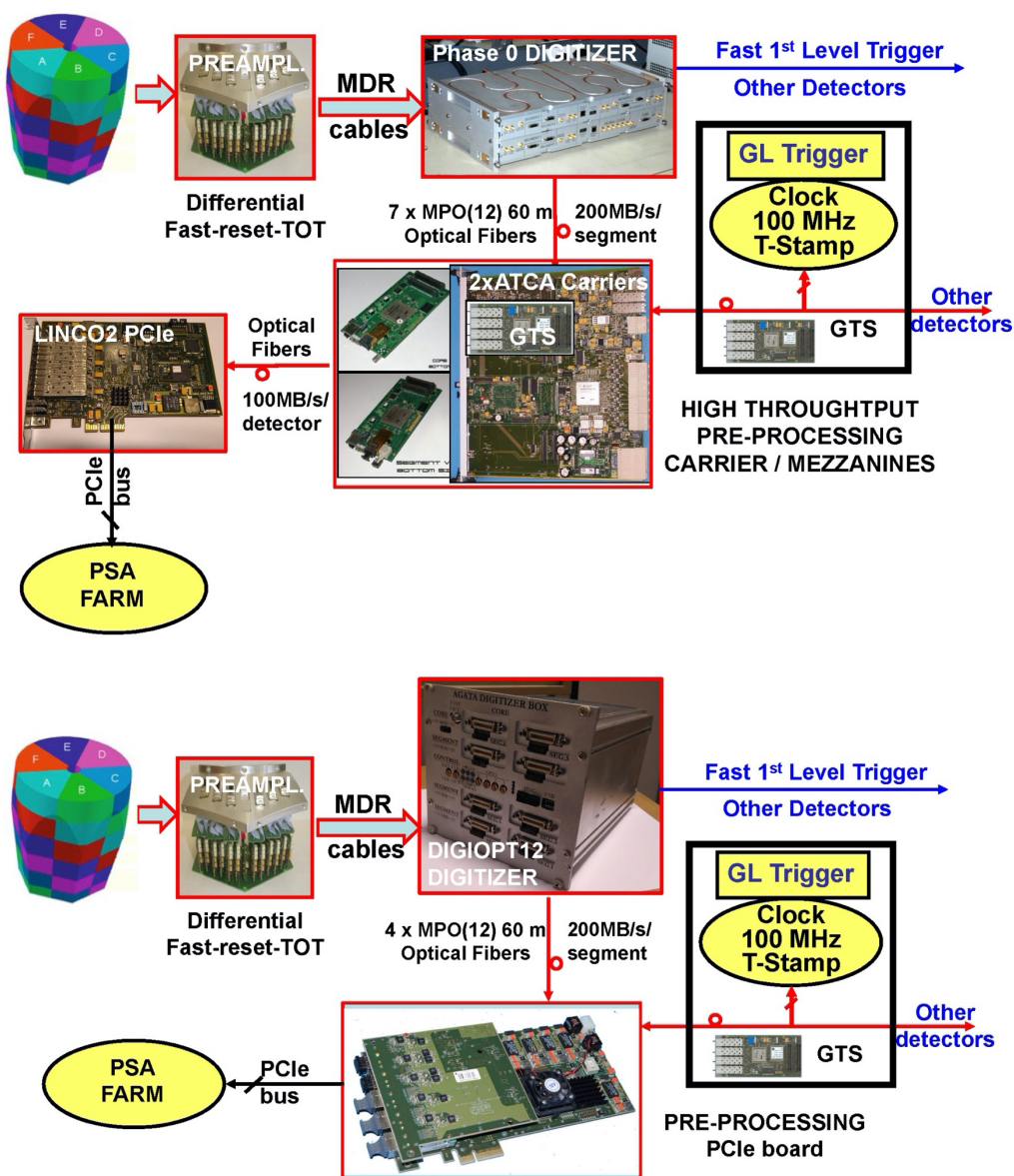

Schematic diagram of the Phase 0 (top) and Phase 1 (bottom) AGATA Front-End electronics

The architecture of the AGATA early electronics is a consequence of the processing and Input/Output capabilities available in a single FPGA at the design time (~2005-2007 for Phase 0). Among other features, the Phase 0 and Phase 1 electronics had the pre-processing in a different location with respect to the Front-End electronics (pre-amplifier + Digitizer) and both were connected by a set of long optical fibres.

The data taking flow starts from the pre-amplifiers. Then, the 100 MHz and 14 bit digitizers convert the signal pulses into digital data that are sent through optical fibres, coupled in groups of 6, to the pre-processing stage. The pre-processing electronics, of Phase 0, is composed of mezzanines that contain the processing logic for 6 segments or the core, and are mounted in an Advanced Telecommunications Computing Architecture (ATCA) carrier card. Another mezzanine card contains a link to the Global Trigger and Synchronization (GTS) system. The GTS provides a common clock and a timestamp, and manages the second level of the trigger, which may include events with different multiplicity in the array, or which are combined with complementary detectors.

The architecture for the AGATA Phase 1 electronics (increasing the array up to 45 capsules) keeps the functionality of the ATCA electronics with a higher integration of the system including 12 channels per optical fibre and only one PCIe card performing the pre-processing and GTS interfacing. A common problem to both Phase 0 and Phase 1 AGATA electronics generations is the limited availability of components for construction, repairing and maintenance due to obsolescence. The evolution in components has also some benefits in terms of power consumption, speed and cost which are worth to be profited from. These two aspects make it necessary to carry out a Front-End Electronics (FEE) redesign for the Phase 2.

Introduction to the Electronics for the Phase 2 of AGATA

The aim of this chapter is to propose a solution to build a scalable and stable Front-End and Back-End (pre-processing) Electronics system for AGATA beyond Phase 1, tracking the best technical solutions for the full 4π array.

Note that in principle we plan to have the same or equivalent pre-amplifiers and signal cabling from the Detector Module to the Digitizer.

Presently the current DIGIOPT12 digitizer boards will be used, with minor modifications due to obsolescence, noise improvements, Differential Non Linearity (DNL) improvements, introducing of a sliding scale, and possible excluding the transceivers from the design.

The pre-processing board will be installed together with the DIGIOPT12 boards and will act as well as control card for the programming and clock distribution.

For the design of the pre-processing and readout boards, we have considered the following important issues:

1. Interface between front end electronics and PSA Farm servers should not rely on any customize hardware interface,
2. Simplified and autonomous electronic modules to ease maintenance and minimize impact of possible rework due to obsolete components in future,
3. Highly integrated solution to ease the installation in experimental area,
4. Readout based on high bandwidth network technology (up to 10 Gb/s per crystal),
5. Stable and scalable architecture of the AGATA Back-End Electronics & Data Flow architecture (for which the necessary performances must be fulfilled from 45 crystal to the completion of the full array),
6. High level of monitoring, diagnostic and debugging with friendly graphic user interfaces,
7. Modularity to allow for the use of new technologies when available and suitable for the objectives of cost reduction and higher integration,
8. Maintenance of the system by external companies or using commercial off-the-shelf System on Modules (SoM), is highly recommended since it insures the availability of spare parts through the lifetime of the experiment,
9. Possibility to have a portable version to install them in Scanning tables, Acceptance Test labs, Host labs for detector maintenance labs so that results can be compared using the same instrumentation between experimental area and labs,
10. Built-in self-tests and built-in embedded software so that the system can work without network access to servers and complicated infrastructure. This instrumentation must have an independent and easy software interface to perform a crystal acquisition. If a computer should be connected and needed then this computer is part of the material. It is mandatory to simplify the installation. This must be defined during the project technical definition and should not need adding some software every time there is a new option required by the users. All requirements should be known during the design period, so that the hardware, firmware and software teams can integrate all requirements in this instrumentation,
11. Open Source software and firmware available for the full collaboration for future upgrades, training, dissemination etc...
12. All parts fully documented on engineering and user levels.

We also considered, for the long term of AGATA, the possibility of higher integration and power consumption reduction in the AGATA core and segment pre-amplifier. Exploring the ASIC technology for the AGATA pre-amplifiers, i.e. the integration of the pre-amplifier and the ADC in the spirit of the Digital Pre-amplifier module. Nevertheless, the technology for ASIC and FADC is presently unable to offer a “real” solution for the Digital Pre-amplifier requirements. The collaboration will explore this

possibility as soon as it is available, and it will be incorporated to the project if it improves the performance and reduces the cost.

Electronics General layout

The proposed electronics general layout is shown in the following figure:

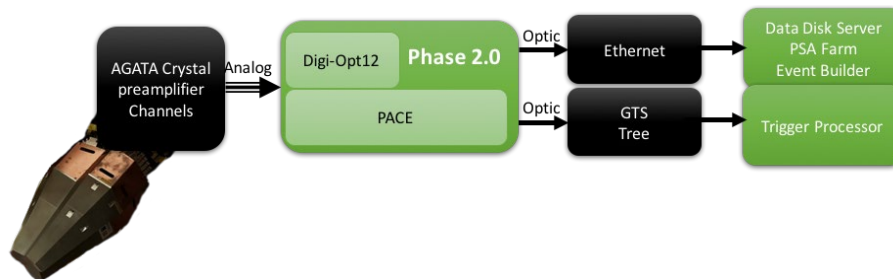

General layout of the AGATA Phase 2 electronics

The elements of the system are the Digitizer system and the Pre-Processing and Communication system (PACE) composed of the following parts:

- Digitizer Board (DIGIOPT12),
- The Data Transfer lines,
- Input Data Motherboard (IDM),
- Pre-Processing and Control board (CAP),
- Read-Out board (STARE),
- Trigger and Synchronization Interface (GTS or alternative system),
- The monitoring/Inspection Hardware,
- Pre-processing, control and monitoring Firmware and software,
- Mechanics, Power Supply and Cooling System (Temperature Stabilization).

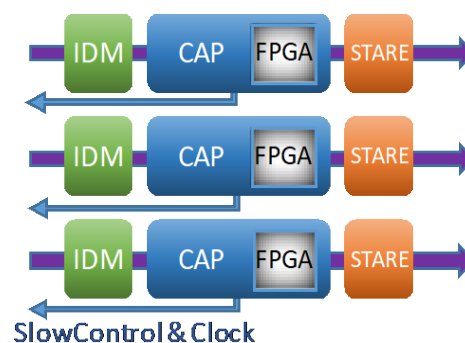

PACE scheme: Data collection, pre-processing and read-out

Digitizer: New DIGIOPT12 Board

It has been considered feasible to continue using of the DIGIOPT12 cards for the Phase2 of AGATA. The actual version of the DIGIOPT12 board is the outcome of optimizations and improvements guided by the user's feedbacks (including range adjustment, fast trigger channel optimization, filtering of the ADC voltage reference). DIGIOPT12 developments are now focusing on the issues related to ADC Differential Non Linearity (DNL) as seen after Moving Window Deconvolution trapezoidal filtering. In nuclear spectroscopy DNL issue is much more critical than in typical applications of flash ADCs. Nevertheless, as DNL is intrinsic of flash ADC architecture, changing FADC model or increasing to 16 bit resolution may not be helpful (current FADC already has an internal 16 bit architecture but the two Less Significant Bits (LSB's) are not transmitted because they are at the noise level). After completion of the study of the ADC DNL (in progress) we will implement all changes aimed to mitigate its effect, such as the use of sliding scale correction, a range optimization, the use of Digital to Analog Convertors (DACs) instead than Digipots for DC offset setting etc...

New opamps for analog signal conditioning

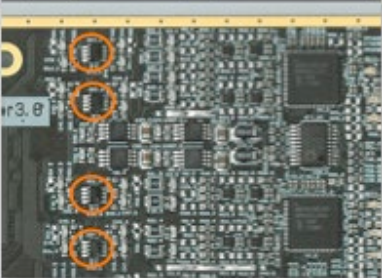

"Old" opamp: **AD8030**
 $e_n = 16.5 \text{ nV} / \text{Hz}^{1/2}$

↓

"New" opamp: **LTC6247**
 $e_n = 4.6 \text{ nV} / \text{Hz}^{1/2}$

New opamps feature lower noise and larger bandwidth

DACs instead than Digipots for ADC DNL characterization and sliding-scale correction optimization

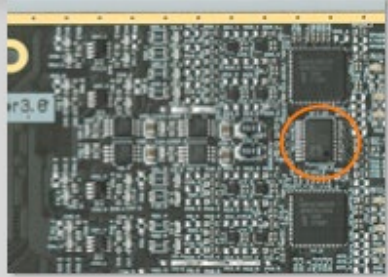

Use of DACs is envisaged in place of Digipots for high-resolution DC offset adjustment over the full ADC range. The DC offset may then be dynamically changed in order to implement the sliding scale correction as a cure to ADC DNL.

Recent and on-going developments in the DIGIOPT12 Board

DIGIOPT12 boards have been built until now in an industrial environment. The production yield, evaluated over the production of more than 92 boards, has been excellent and the failures of the boards almost negligible during the three years they have been functioning at the setup.

Presently the company is not anymore available and actions to translate the DIGIOPT12 design into the CAD format EAGLE, is being done. Modification of the design to incorporate the sliding scale hardware will be done.

The production is planned to continue through an industrial partner, that is already under investigation, for the 2020 production.

Pre-Processing

The following figure shows the functional blocks of the Pre-Processing system. Some of them correspond to physical boards and some just to functionalities that should be implemented either on hardware or firmware or split in both domains. In the following subsections a detailed description, both of the hardware and firmware, of these functional blocks is presented.

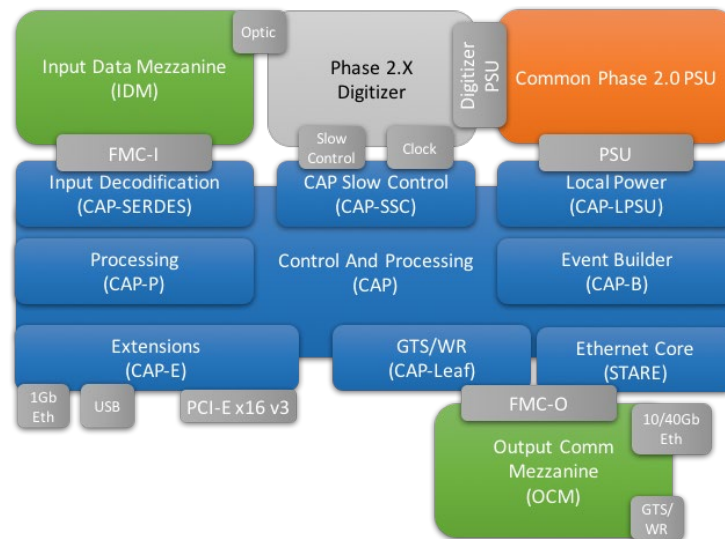

AGATA Phase 2 Electronics functional layout

The Data Transfer Lines

The elimination of the optical transceivers and optical fibres, between the DIGIOPT12 boards and the IDM concentrator of the pre-processing system, represents both a reduction of the power consumption in the boards and a reduction of costs. With this purpose a Flex-Rigid PCB connection has been designed, as a follow-up of the planned vicinity of the DIGIOPT12 boards and pre-processing boards (see following figure).

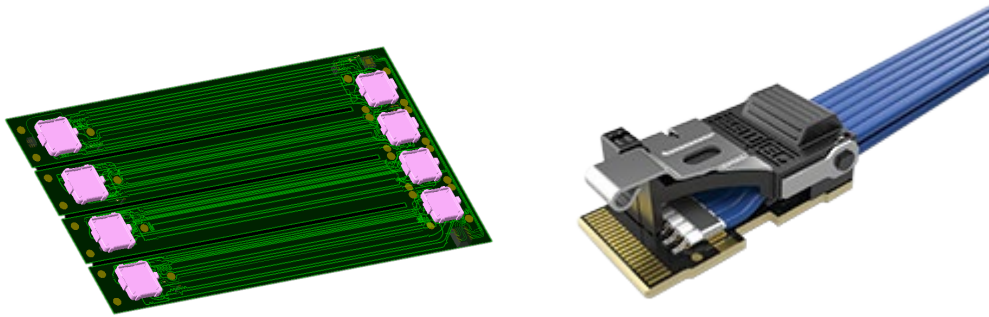

The PCB Flex-Rigid connection (left) or FireFly cabling (right) replaces the transceiver and optical fibres.

The other option could be copper based FireFly cables. The cost estimates for the Data Transfer lines, even for a limited production, is about 400 € for Flex-Rigid PCB and 250 € for the FireFly per Digitizer, compared with the 1.6 k€ of the transceivers for the previous phase electronics.

The Input Data Motherboard (IDM)

The IDM (see following figures) is the subsystem conceived to receive the data coming from the digitizers. It will receive the data from one crystal by copper connection or optical fibre and will implement a reduction in the number of input links to send to the CAP pre-processing board by using low-cost Time Domain Multiplexing devices; in this way, the number of high-speed transceivers used in the FPGA will be reduced. In Phase 1 electronics, the DIGIOPT12 board sends approximately 2Gb/s per each of the twelve output channels. This implies an aggregated bandwidth of 76Gb/s for 38 channels (36 segment + 2 core channels).

The first implementation of the board, used in the conceptual design of the electronics, has been produced and is being tested.

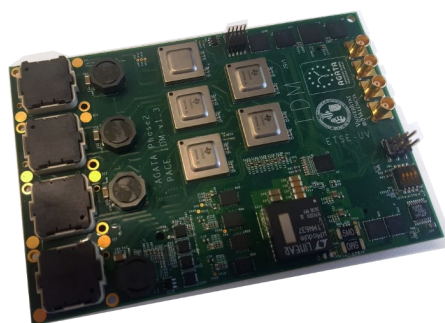

First version of the IDM board with only the concentrator part

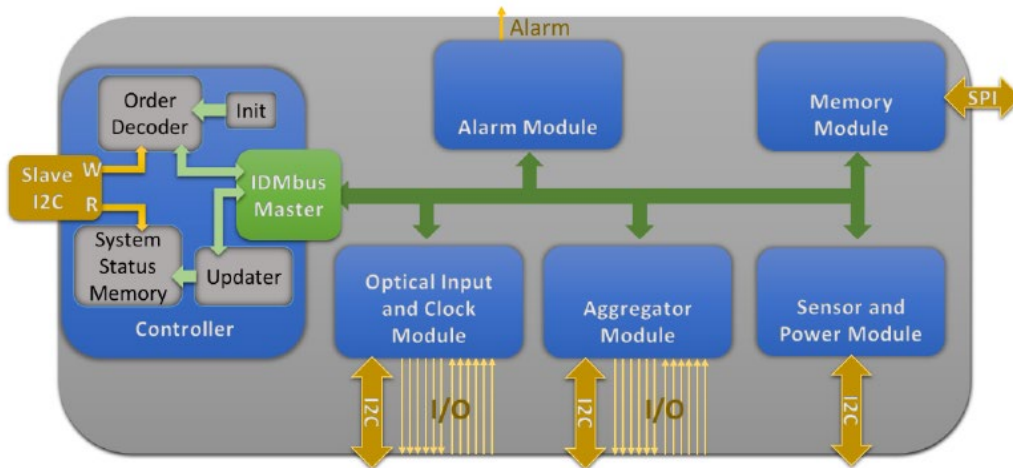

Functional block diagram of the IDM board

The Control And Processing board (CAP)

The main purpose of this board is to process the data from one crystal, generating the Local Trigger and extracting the Energy and Time information as well as the traces for the PSA analysis in agreement with the GTS Trigger Validation/Rejection cycle. A second task carried out by the CAP board is to provide intelligent slow control through Ethernet IPbus, for all the subsystems including the DIGIOPT12 boards. A description of the functionalities will follow in the Firmware section.

In addition, the interface between CAP and the Read-out STARE mezzanines will be designed in order to ensure the possibility of having triggered digitized traces of a capsule in a scope mode (with 10 Gbps bandwidth 6 segments can be displayed per crystal, increasing to 12 segments with 20 Gbps) and to display also the induced signals in the neighboring segments. Finally, the GTS (or equivalent Trigger and Synchronization system) functionalities will also be incorporated.

As mentioned before, the Control And Processing board is the core of the system and it holds the Master FPGA. Based on a balance in cost, processing capability and number of high-speed transceivers, a Virtex new generation FPGA is considered as the best option to perform the crystal data pre-processing.

Presently this board is not yet designed but during the conceptual phase design an evaluation board is being used with two FMC connectors to be able to connect the other mezzanine prototypes.

Among the possibilities for the design of this board, the use of Commercial-Off-The-Shelf (COTS) System on Modules (SoM) boards is under evaluation. This will facilitate the design and production as well as guarantee spare parts. The best candidate is the Trenc Electronic “TE0808-04-BBE21-A” (mounting a Zynq UltraScale + XCZU15EG -1FFVC900E).

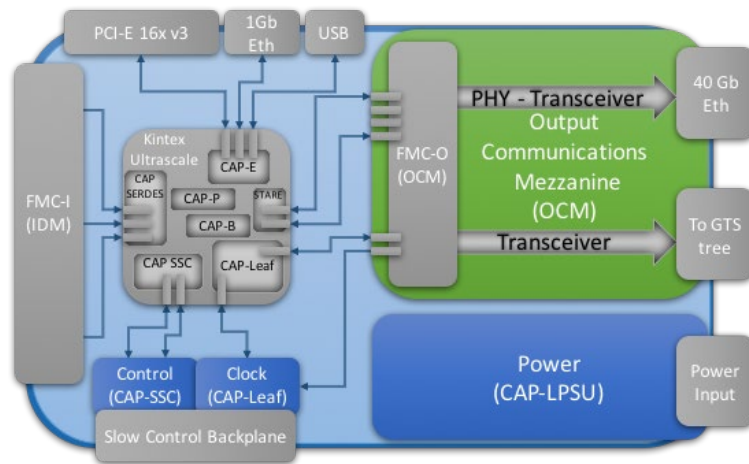

Control And Processing (CAP) board block design

As mentioned before, the CAP board implements the slow control logic for the DIGIOPT12 boards, digitizing the signals from an AGATA capsule, in the same way as it is presently implemented in the Digitizer Control Card. The system would be scalable and flexible to adapt to future DIGIOPT12 upgrades.

A power supply unit or units would provide all the voltages and current needed for the operation of the system. One key point in the design of this unit is the fact that its efficiency should be as high as possible to minimize the power dissipation and, thus, lower the cooling requirements.

The GTS leaf functionality could be provided by the FPGA in the CAP board with a physical connection (optical fibre) to the GTS tree. It is planned to implement the GTS hardware in the CAP board (see in the following figure the low complexity in the NUMEXO2 implementation). It is also foreseen to have compatibility with other Trigger and Synchronization systems.

The firmware necessary to work with the GTS is composed of two part, the GTS leaf IP firmware and the Read Control IP firmware (also called ADC Interface IP in the NUMEXO2 version of GTS).

The GTS IP firmware, in charge of the interaction with the external GTS tree as well as of the alignment of the clock, will be imported from the NUMEXO2 GTS project IP and will be already included in the proof-of-concept implementation. The Read Control IP will be built from the firmware of the previous phases of AGATA including the improvements contained in the NUMEXO2 firmware project.

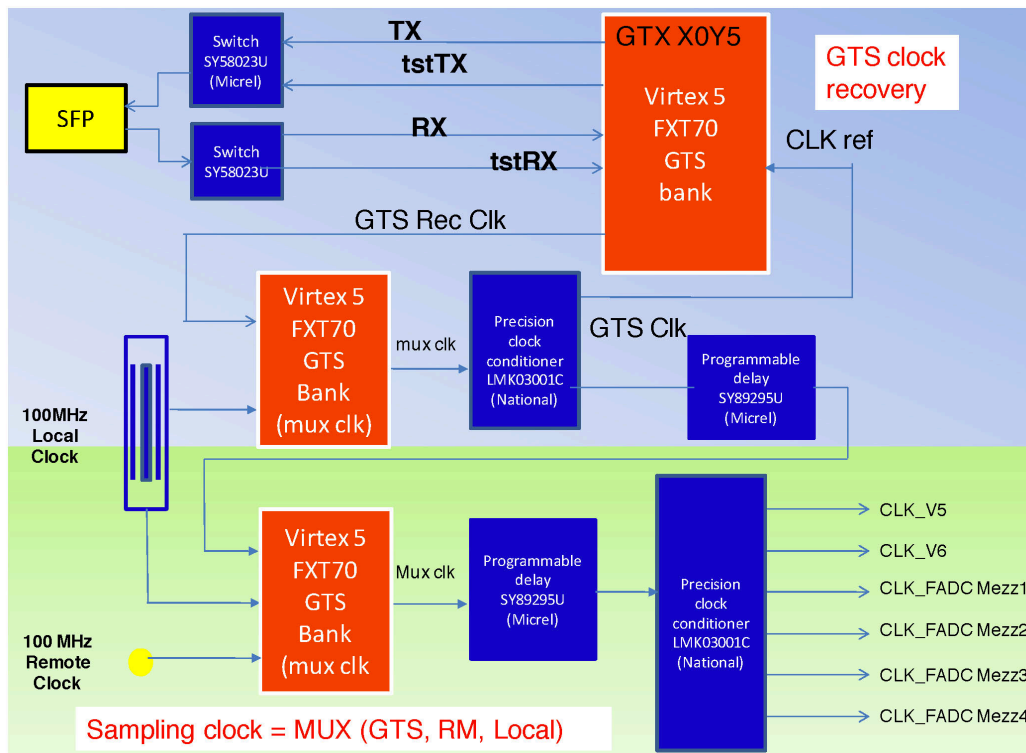

Implementation of the GTS clock recovery and clock management hardware designed in NUMEXO2 (courtesy of M. Tripon, GANIL, and collaborators).

The Serial Transfer Acquisition Readout over Ethernet (STARE) mezzanine

This mezzanine is aiming to provide a standard Ethernet capability to transfer data from the experimental hall to the PSA farm servers avoiding dedicated interfaces. The use of high capacity Ethernet network allows to remove critical customized cards inside the computer farm. A sizeable reduction of fibres between the experimental hall and the location of the PSA farm is also expected. In the worst case we will use only one fibre per crystal.

The use of 10 Gb Ethernet will allow to cope with the maximum data transfer rates within the AGATA specifications independently of the use of hardware or software trigger processor and will offer the opportunity to use longer traces if needed.

Ethernet protocol offers the possibility to swing data buffers among destination server, optimizing the data flow. The proper destination will be chosen as a function of server load, network traffic and data acquisition system configuration. Beside the load balancing capacity, this technology will offer the opportunity to send data to the different PSA servers.

With the current electronics, the scope mode which is useful for monitoring the experiment (visualization of the signals during the run) is not possible. The proposed design will include this functionality. Monitoring one channel in scope mode requires a bandwidth of 1.6 Gb/s.

A SoM implementation is being considered for the STARE board, in particular the best candidate presently is the Trenz Electronics “TE0841-02-41C21-A” (mounting a Xilinx

Kintex UltraScale KU040). This SoM module could be implemented in the IDM Motherboard or in a dedicated mezzanine.

The FPGA implemented in this SoM will have the firmware able to provide the Ethernet interface and will control the very high-speed links to the Ethernet transceivers. The Ethernet link will provide the data readout, the monitoring and setup control. One external clock will also be available.

The main functions in the FPGA mezzanine hardware and firmware of STARE are:

- Electrical interconnections with mezzanine connectors and gigabit transceivers,
- Embedded Linux OS used for readout manager control and global system setup control,
- Readout bloc management,
- Ethernet protocol management (embedded IP),
- Slow control management,
- Gigabit links dispatcher.

In the cost table, the option with an independent mezzanine has been considered.

Firmware and Software for the Inspection and Electronics Control

The electronics architecture being considered is such that it is directly connected to the DIGIOPT12 FADC cards – where there is no logic in the cards – thus it has to support both the slow control of the pre-processing and the DIGIOPT12 cards as well as the synchronization of the FADCs. The processing board will receive the serialized data from the DIGIOPT12 cards through the IDM concentrator board (to profit from the bandwidth of the FPGA serial ports), pre-process them and take a decision on the trigger request. It will also determine Energy and Time information for the core as well as for the segment channels and it will work on the advanced processing of the baseline. The data will be “Zero Suppressed” and Compressed. A simplified block diagram of the firmware functionalities is shown in the figure below.

The current GGP firmware has not been made available to the AGATA collaboration. Most of the firmware is being redone. This has been done taking also into account the new architecture decided for Phase 2. It has also profit from various parts of the older versions of the pre-processing as well as from newer developments that were made available.

The firmware has 5 main interfaces:

- DIGIOPT12 Channels Receiver: Reception of the digitized channels coming optically from the concentrator (IDM) mezzanines. It includes: Deserialization, Alignment, Buffering, Control signals Management,

- Interface with the FMC readout board (STARE): Communication path to be defined. Buffering via an external memory seems necessary before transferring data packets to the STARE board,
- GTS interface: Available new implementations from EXOGAM2 and from NEDA projects. Necessary to migrate to Kintex Ultrascale and to integrate in the global firmware,
- DIGIOPT12 Controller,
- General Slow control of the full electronics system: Configure all internal registers. Best option 1Gb-Eth / IPbus interface if bandwidth should be saved on STARE board, the IPbus interface could be extended to transfer channel data in scope mode in order to do long trace analysis and to configure properly the channel settings (trigger, MWD) before an acquisition run.

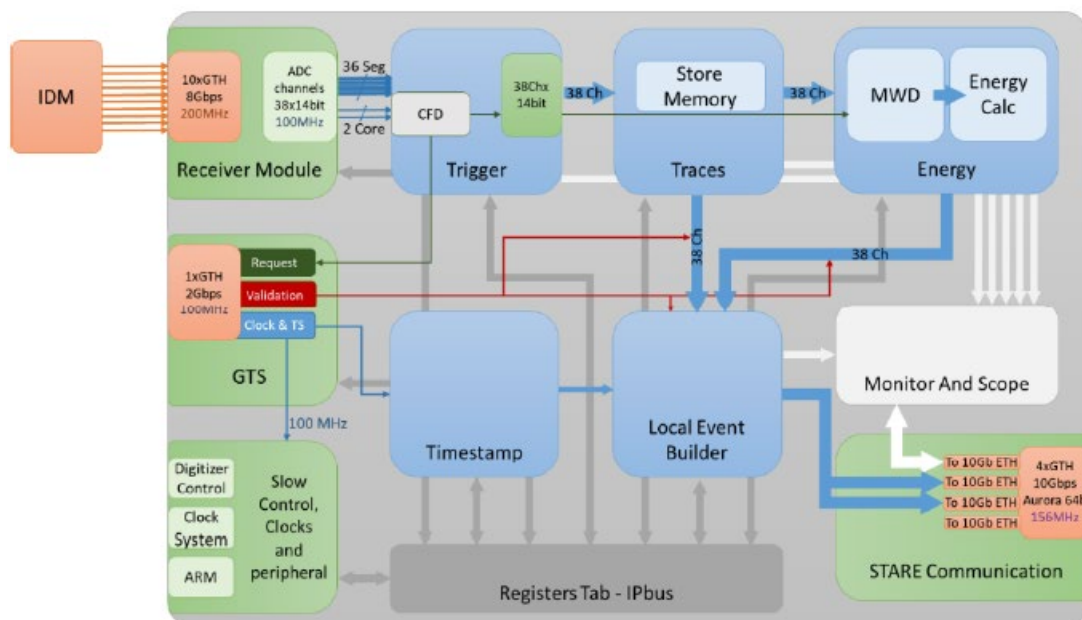

Control And Processing board (CAP) Firmware block diagram

The data path includes:

- High Frequency De-serializer,
- FADC data Stochastic Latency aligner,
- Internal Trigger Request determination LED/DCFD, triangular shaper and a threshold etc. This includes the evaluation of the segments with net charge signals,
- The possibility to have the logic OR of the “segment” triggers instead of the core trigger,
- Incorporation of the GTS Local Trigger/Trigger Request Timestamp to the data buffer,
- Pre-trigger and post trigger sample storage,
- Advanced baseline determination (all segments with net charge and core),

- MWD Energy Determination (all segments) with the advanced baseline for Phase 2,
- Storage of the data for the cores and segments, with selection of segments with net charge and mirror signals for PSA processing for Phase 2,
- Data compression for transmission,
- Management of the GTS Validation/Rejection,
- Delivery to the TCP or UDP FIFO.

Data Transmission path includes:

- Slow control of the digitizer boards DIGIOPT12 and the pre-processing card itself. Control commands come from Ethernet and the Control Card should communicate with the different devices using standard serial protocols,
- Ethernet register server for the Configuration and control. It has to manage the slow control of the pre-processing as well as DIGIOPT12 card (Management by the GEC and Run Control),
- TCP/hand-shake UDP Data transmission to the Data Flow,
- Management of the TCP/UDP IP block.

The GTS and clock management includes:

- GTS management, configuration and alignment,
- Management of the Trigger Request (TR) and TR Timestamp,
- Management of the Validation/Rejection FIFOS,
- Reception and broadcasting the 100 MHz clock of the GTS with minimum contribution to jitter and skew.

The status of the firmware preparation, is the following:

- ETSE and IFIC in charge of the IDM data IPS's: Data reception in the IDM Test-bench is fully functional since late 2019,
- IPHC Strasbourg in charge of the migration of the previous STELLA project,
- GbE + IPBUS for SlowCtrl & Data transfer to PC: done and fully functional,
- SERDES block (compliant w/ FMC112 ADC Data): done and to be tested,
- DSP blocks for algorithms (Trigger, MWD): done and to be tested,
- FIFO primitives & BRAMs for Data buffering: some issues to be investigated,
- READOUT block and I/F with GUI via GbE/IPBUS : Requires modifications,
- Add synchronization/timing features based on previous designs : to be done,
- GTS leaf f/w from NUMEXO2 (GANIL) : to be done,
- Read Control GTS IP : to be done,
- Add features of Control of the DIGIOPT12: to be done,
- Add the block (IDM channels receiver) developed by ETSE and IFIC,
- To receive channel data from IDM and to Transfer data to STARE, need to Define transfer protocol, registers tables, data formats & acquisition modes (links with s/w by IPBUS), diag, etc...

Since the outline design is still under discussion, the full list of VHDL code and hardware required has not yet been finalised. An important U.K. contribution is identified in the signal visualisation and diagnostics. Compared to other systems (like the Lyrtech system in JYFL designed by STFC Daresbury) the availability of signals from firmware algorithms for inspection is presently very poor in AGATA. It is necessary to visualise, for example, the different stages of the MWD energy algorithm. A good example is that the user needs to look at the trapezoid flat top while adjusting the PZ correction for pre-amplifier decay time to ensure that the flat top really is flat, eliminating any slope by fine-tuning the PZ correction factor. The work would be primarily VHDL, maybe some hardware design, and would include software to work with the visualisation VHDL firmware to display signals.

Proposal for inspection:

- Visualisation of input signals,
- Visualisation of MWD algorithm intermediate results (parameter adjustment),
- Timing of signals from ancillary detectors,
- Timing of trigger signals,
- Digital diagnostics for key GTS signals, readout signals.

In terms of specifications, all of these inspections have to be accessible remotely, and should be selected by software. Possibility to compare two channels as well as different signals within one channel is necessary. All should have the option to show the buses as “analogue”, with a user-friendly GUI.

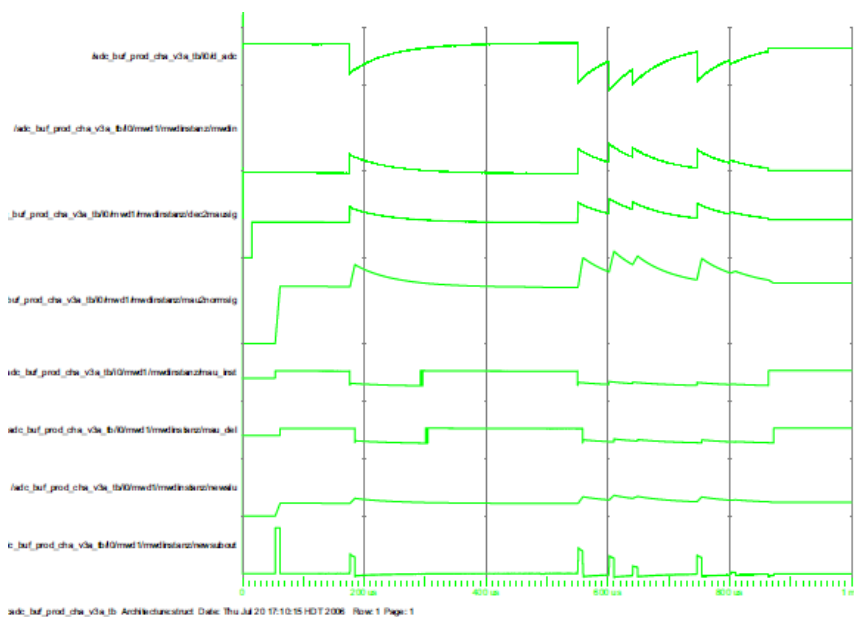

Example of visualization of the MWD processing

Mechanics and Power Supply Unit

The basis for the mechanical design of the PACE system is to keep the principle of the one used in the Phase 1. It consists of a 3U crate for the processing of the signals corresponding to one AGATA triple cluster. In the Phase 2 version it will also include the pre-processing hardware (in the Phase 1 the PCIe pre-processing board was placed in the PSA servers) connected to the DIGIOPT12 cards through FireFly cables. The following figure shows the concept proposed which should be investigated in detail.

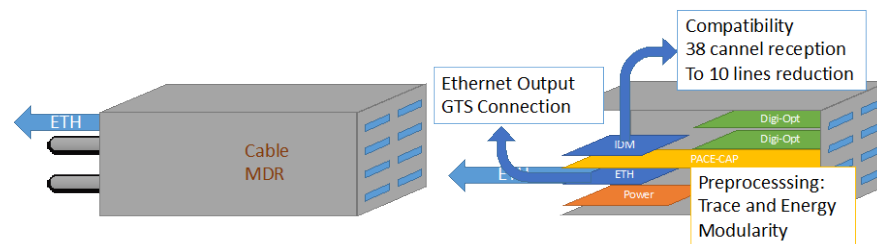

Mechanical proposal for the full system

A new Power Supply Unit (PSU) is being developed. The power supply requirements have been estimated as 110 W from the configuration including 4 x DIGIOpt12 (no optical transmission), CAP (pre-processing) + STARE.

The power supply distribution is shown in the following figure together with the PCB of the new PSU compare with the previous one.

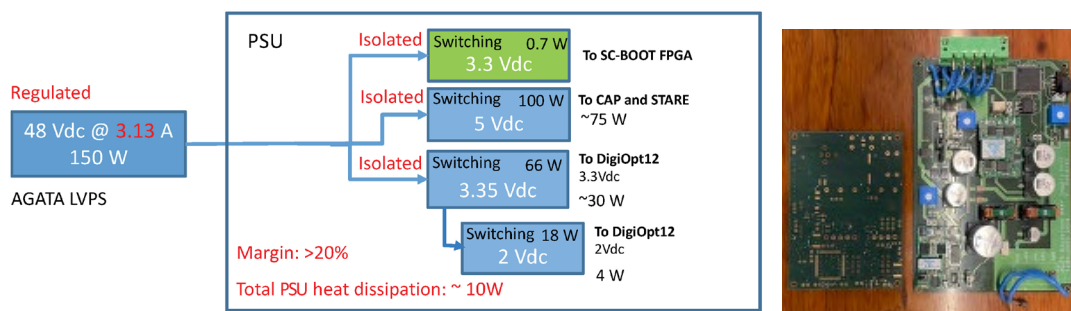

Power supply distribution among the required voltages and size of the new board compared with the Phase 1 Digitizer PSU.

Global Trigger and Synchronization system and Trigger Processor

The present AGATA GTS system has limitations that should be overcome for Phase2:

- Presently, due to the initial specifications, the number of available independent channels is limited to 255. This is a strong limitation when coupling with other detector arrays based on GTS,
- Difficulties to produce the present tree hardware. Obsolete components for the mezzanines, the last trigger processor has been produced by EXOGAM2. Large number of FIFOS mezzanines needed for the GTS Tree structure since, in the present design, each FIFO element has 3 Inputs and 1 Output. A GTS tree for 45 capsules requires presently a minimum of 23 FIFOS and 1 ROOT mezzanines,

- In strong disagreement with the initial specifications, losses in the GTS transfer were found when approaching 1MHz of trigger requests: with 1MHz requests from AGATA + NEDA we have from 5 to 10% losses. It is unclear whether they are coming from the protocol itself, the performance of the FIFOs or other reasons,
- Slightly different behavior on the Validation success comparing the ATCA (full GTS protocol) and the GGP and NUMEXO2 (simplified protocol with no identifier),
- Need broader compatibility on clock and synchronization for complementary instrumentation.

Two solutions have been discussed in the Working Group:

- Upgrade of the present protocol, to be done by INFN-Padova because there are no other experts on the development. It will provide an easy back-compatibility. Presently, after repeated contact attempts, we have no feedback from INFN-Padova on this possible upgrade,
- To migrate to a new Global Trigger and Synchronization. In particular to SMART, a new Global Trigger and Synchronization system being developed at GANIL, with large hardware and specification compatibilities with GTS.

We foresee difficulties to make the system compatible with previous versions of the AGATA electronics. Especially critical for the relatively recent GGPs, the pre-processing boards produced from 2013 to 2018, since the AGATA collaboration has no access to the GGP firmware source code.

The SMART system, still at the conceptual level, is being proposed by the GANIL GAP (G. Wittwer et al.) and a functional prototype is being expected for early 2021.

Regarding the Trigger Processor, we plan to continue with the GANIL EXOGAM2 trigger processor concept. Several improvements have been planned following the commissioning and the first experimental campaign at AGATA performed with this Trigger Processor.

The SMART Synchronization system and Trigger Processor

The SMART Trigger and Synchronization system is based in the micro-TCA standard. The SMART hardware is built around two boards, the HUB board and the ROUTER board. The HUB and ROUTER boards are in principle connected by standard LC/LC optical fibres, nevertheless, the distribution of the clock and timestamp can also be done through the micro-TCA, thus providing a larger flexibility for the number of trigger request sources in the system.

Both HUB and ROUTER boards are very similar, build as motherboards with the interfacing, hosting a SoM Trenz TE0784, with a high performance Xilinx FPGA.

Both HUB and ROUTER have 16 high band transceivers. The figure included below shows schematically the hardware structure of SMART.

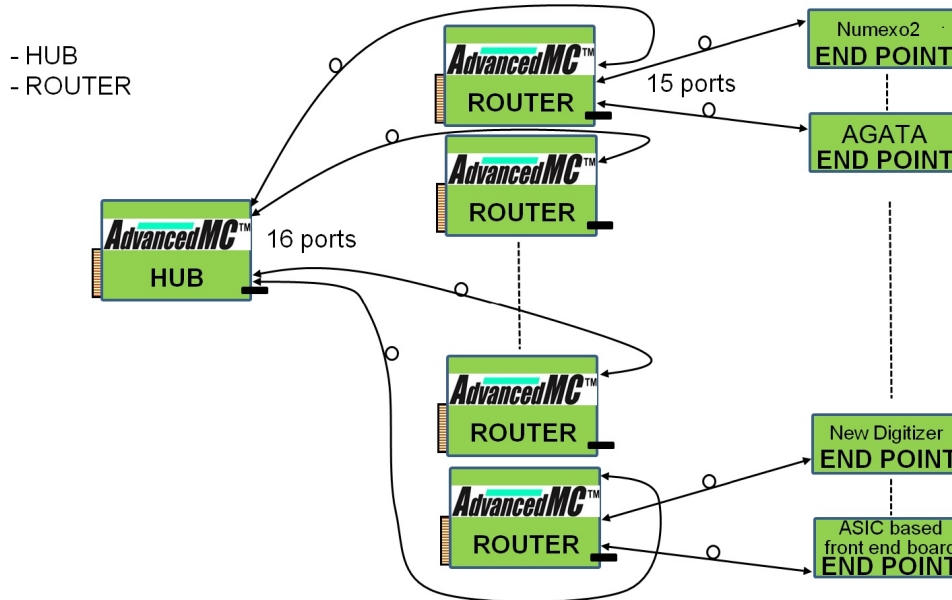

Scheme of the SMART Trigger and Synchronization system developed at GANIL

The SMART timestamp distribution is thus more similar to a star distribution than a tree distribution, reducing substantially the needed hardware.

SMART has a double time alignment, one for set-ups where only the rough clock alignment is sufficient and the fine alignment with about 300 ps resolution for systems like AGATA, requiring fine time alignment.

The timestamp and trigger request are transferred through the SMART system in a small packet protocol.

The HUB board will act as root in the synchronization system, but also as Trigger Processor. A new version of the GANIL EXOGAM2 Trigger Processor will be implemented in the HUB FPGA, thus a larger capacity FPGA might be needed compared with the ROUTER boards. To have the root and Trigger processor in a single board will simplify the communication and enlarge the band-width (the HUB has 16 high speed transceivers) of the trigger requests.

The HUB board will have a SMI input for an external clock as well as capability to read and incorporate an external timestamp. This will be useful for the coupling with the White-Rabbit synchronization system to be used in various laboratories in Europe, including FAIR.

We are still discussing how to incorporate conventional non-digital systems – in particular in VME environment – to the SMART synchronization and Trigger system.

A micro-TCA BEAST board already exists and could be coupled to the SMART system with the CENTRUM one, used in various instruments. This board has an input for an external trigger request. The timestamp will be distributed in the micro-TCA backplane. Nevertheless, the discussion on this aspect of the project is still ongoing.

For the SMART system the HUB cost is foreseen as 5.3 k€ and the ROUTER cost is foreseen as well of the same order: 4.8 k€.

In order to instrument AGATA, it would be necessary to have 12 ROUTER boards, distributed in 2 micro-TCA crates and 1 HUB board in 1 micro-TCA crate.

1 micro-TCA Crate, 1 Power Module (PM) and 1x10Gbe MCH (micro-TCA Carrier Hub/Switch) cost roughly 10 k€. Thus, the total cost of the crates and switches is estimated to be of the order of 30 k€.

The total cost for the Global Trigger and Synchronization system, including the Trigger Processor is estimated to be of the order of 120 k€, i.e. about 700 € per channel (2 k€ per ATC).

This is to be compared with the GTS cost from the previous phases, that was of the order of 5 k€ per ATC, considering all the associated infrastructure.

Summarizing, we expect to start in 2021 with the present GTS system but we would need to migrate towards the SMART system during the early years of Phase 2. Note that the pre-processing embedded GTS hardware is compatible with the SMART hardware.

A formal agreement and discussion of the AGATA collaboration contribution to the SMART developments are still to be discussed.

The Digital Pre-amplifier Development

Since the very beginning of the AGATA project, one of the long term goals was to instrument the array with Digital Pre-Amplifiers, i.e., instrumentation with electronics that provides the Digital output close to the encapsulated detectors. The Digital Pre-Amplifier technology, identified by the collaboration, involved the following developments for the very front end electronics of the array:

- The development of analog, cryogenic, ASIC preamplifiers that will be installed in the cold part of the AGATA Triple Cluster cryostat. Presently the only pre-amplifier part that is cryogenic corresponds to just the input FETs and feedback capacitance and resistance that are cooled to minimize preamplifier input noise. The advantage of this method is that signals from the detector are amplified as early as possible in the signal processing chain, thus maximising signal to noise ratio and improving spectral quality.

- Low-power consumption sampling ADCs will be placed in the electronic compartment of the triple cryostat possibly in the vicinity of the feedthroughs . The requirements for such ADCs are: high integration, ENOB ≈ 12 , low-power consumption and low cross-talk between channels.
- The pre-processing electronics will be placed in the neighbourhood and with copper input connection, avoiding power consuming optical transceivers and large amounts of long optical fibres.

The development of low-noise, analog, cryogenic ASIC pre-amplifiers is of interest not only in our field but in general when cryogenic detectors or systems require a prompt amplification. Early works for Astroparticle physics (A. Pullia, et al., IEEE Nuclear Science Symposium Conference 2008 pp. 2056, S. Riboldi et al., IEEE Nuclear Science Symposium & Medical Imaging 2010, pp. 1386) have proven the feasibility of the development but also the difficulties to control the behaviour of the ASIC components at cryogenic temperature. Developments on ASICs working at cryogenic temperature are of interest for several institutes of the collaboration as STFC-Daresbury UK (STFC's ASIC design group is already developing cryogenic ASIC technology), INFN-Milano Italy XXX and ETSE-University of Valencia Spain.

Presently, state-of-the-art low noise, highly integrated, fast sampling ADCs (100 Msps) have a power consumption between ≈ 100 mW / channel (Octal ADC Analog Devices AD9681) and ≈ 70 mW / channel (Octal ADC Texas Instrument ADS52J65). Although their power dissipation is close to fitting within the necessary power budget, it is not low enough to integrate the ADCs in the present warm pre-amplifier compartment of the cryostat. Nevertheless, testing such multichannel ADCs will be performed by AGATA groups, expecting to find optimal candidates as new devices come onto the market during the research phase.

Our Phase 2 pre-processing electronics has been designed with a reconfigurable input stage that can accept inputs from either the present preamplifier design or the new Digital Pre-Amplifier.

The schedule of this development is still largely undefined and, in any case, will not be completed before 2025. In the case that this development is successful, its cost affordable and the performance equivalent to or better than the classical preamplifier design, we plan to integrate the ASIC and Digital Pre-Amplifier technology in the Phase 2 front-end electronics.

Upgrade of Phase 0 and Phase 1 Electronics

The early electronics of AGATA called Phase 0 were designed around 2005 and produced in 2007/2008 and 2011/2012, for 15 and 10 channels respectively. All of them were produced with components that are presently obsolete. In 2022 a sizeable amount of boards will have about 14 years and there will be great difficulties to maintain the

hardware. In particular, the situation of the digitizer core and segment boards is really critical, as they are based on Virtex II FPGAs, that are obsolete and which production has been discontinued since 2012. The maintenance of the board is presently extremely difficult.

Some of these early digitizer + ATCA channels are being replaced during the late Phase1 period. We propose to complete the full replacement of the early 25 digitizer + ATCA channels in the early stage of the AGATA Phase 2. Note that, differently from the newer Phase 1 channels, the full Phase 0 electronics, digitizer and pre-processing boards, has to be replaced, with a total cost, per channel, of 16.7 k€.

Additionally, in 2025 the project definition foresees a full upgrade of the Pulse Shape processing part (see Pulse Shape and Data Flow section), that requires dispatching capabilities in the pre-processing electronics. This capability is not existing in the Phase1 electronics since it is still a point-to-point optical fibre read-out. Moreover, Phase 1 electronics was designed in 2010 and produced since 2013 and already has relevant obsolescence issues. We therefore foresee for 2025 the replacement of the Phase 1 electronics with new Phase 2 electronics channels, reaching the final processing capabilities. Moreover, the SMART Trigger and Synchronization system will also be incorporated to the array.

	2020	2021	2022	2023	2024	2025	2026	2027	2028	2029	2030
Phase 0 Electronics	Yellow										
Phase 1 Electronics	Yellow										
Phase 2 Electronics			Green								
AGATA GTS / TP	Yellow										
SMART GTS / TP						Green					
Point-to-Point Readout Single Node PSA	Yellow										
Ethernet Dispatching PSA on HPC						Green					

Schedule for the Electronics Upgrade in Phase 2
(yellow: use of existing electronics, green: use of Phase 2 upgrades)

Construction

The Electronics Working Group commits to get, as much as possible, the parts of the AGATA Phase 2 electronics produced in an industrial way, with acceptance tests and maintenance or replacement possibilities.

DIGIOPT12 boards: already the present DIGIOPT12 boards have been produced in an industrial environment and it will continue this way.

Pre-processing boards: we intend to use SoM (System on Modules) commercial boards for the pre-processing PACE FPGA and the Ethernet STARE interface. Our target are boards with guarantee of production and maintenance for a minimum of 15 years. Only

the IDM and STARE motherboards, the Power Supply units and the backplanes, will be customized since the input-outputs for the connection to the DIGIOPT12 boards, inspection lines, control, etc..., require a custom design.

The new Global Trigger and Synchronization system SMART is being designed as well with SoM boards.

Costs, Timescale & Efforts

The following tables show the 2020 estimated budget for the initial production of 30 systems and the task assignment and effort contribution of the Electronics Working Group partners in the development of the proposal.

The present budget implies a cost of about 16 k€ per crystal excluded the Global Trigger and Synchronization system.

Total production costs, including Phase 0 and Phase 1 upgrades, to complete the electronics of 45 ATCs is expected to be **2234 k€**, and to complete the electronics of 60 ATCs is expected to be **3097 k€**, assuming that the production will be done in batches of a minimum of 30 units.

Table 1- Production Budget in k€ for 30 units (2020 reference cost).

DIGITIZERS					
	PCB	Mounting	Components	Subtotal	
DIGIOPT12 boards (4xchannels so 120)				216,0	
				DIGITIZERS	216,0
PACE SYSTEM					
IDM (x30) (Large Motherboard)	25,0	20,0	80,0	126,0	
CAP (x30) (SoM based)				42,0	
STARE (x30) (SoM based)				45,0	
Power Supplies (x30)	15,0	1,5	3,5	20,0	
Flexiboards (x30)				12,0	
Backplanes (x60)	15,0	3,0	2,0	20,0	
				PACE SYSTEM	265,0
MECHANICS					
CRATE (x9)				4,5	
BOXES (x30)				6,0	
COOLING (x30)				12,0	
				MECHANICS	22,5
				TOTAL for 30 units	503,5

Table 2- Efforts Contribution by Institution.

Institute/University	Contribution	Man Power
IJCLAB Orsay	STARE card implementation, firmware,	4 senior engineers 2019: 0.55 FTE, 2020: 0.85 FTE, 2021: 1 FTE 2 FTE requested to IN2P3
IJCLAB Orsay	Data Flow software development, Control software development.	2 FTE
IPHC Strasbourg	Control and Data path firmware development	2 senior engineers 1.4 FTE in 2 years
STFC Daresbury	Pre-processing algorithms, visualization and diagnosis firmware and software development. Prototyping build and test	3.5 FTE AGATA Grant
TeDRA - University of Valencia and IFIC-CSIC	IDM implementation and firmware design, PACE systems hardware design Digitizer Mechanics and PS, Hardware implementation	1 senior + 1 young engineers 1.5 FTE/year Total: 4.5 FTE
University of Milan	DIGIOPT12 evolution	1 FTE/year Total: 3 FTE
GANIL	SMART development (shared also for GANIL systems)	2 FTE/year for 1 year

Regarding the time schedule, the proof-of-concept is scheduled in two phases: the first one has been performed between Spring and Summer 2019 and the final design of all boards is expected to be completed by mid 2020.

The advanced proof-of-concept, with a hardware and firmware closer to the final ones, will be performed in summer 2020.

The pre-production boards are expected towards the end of 2020 to be ready for production at the start of the new MoU for AGATA 4π , early 2021.

The Timescale for the production is the following:

- Proof-of-concept (advanced) partially done in summer 2019 (to be completed during 2020),
- Conclusions discussed on AGATA week September 2019,
- Decisions on SoMs to be used was taken on October 2019 in order to procure evaluation boards and check firmware compatibility
- Design of final IDM motherboard (mid 2019 – mid 2020),
- Advanced firmware to be delivered mid 2020,
- Hardware/Firmware testing mid 2020 to late 2020,

- Complete prototype ready by the end of 2020,
- Production early 2021 to late 2021,
- Installation: late 2021 – early 2022.

About 6 months of contingency time have been considered in the production timescale.

Production and Maintenance Commitment

Production

The future AGATA electronics must comply with industrial products specifications. There are several constraints to be considered in order to be able to reproduce such electronics at any time, using the same item list and the same production procedure to achieve the same final product. It is extremely important to construct the industrial procedure during the design phase in order to include such constraints in the design process.

The research laboratories cannot afford to work in severe conditions without documentations, providing maintenance and built-in Test benches, obsolete components etc.

The building of industrial specifications must be done in association with an expert private company who is able to maintain, produce and buy in advance specific components, which have a short lifetime on the market place. This is a transverse task that should deal globally with the electronics of AGATA.

The responsibility of this task is to ensure that every subsystem contains the following items: complete design description document, manufacturing files including all the special mounting notes and different constraints, purchase documents, ATP and ATR (Acceptance Test procedure and report), list of short lifetime parts, integration documents and all the production procedures.

Maintenance

To achieve effective maintenance the chosen company will have to insure stockage of enough spare parts and to be able to furnish the AGATA collaboration enough items to replace defected ones.

The SoM products will be chosen with an End of Life beyond the completion of the AGATA 4 π project.

The experience with the previous generation of electronics shows that replacement of complex components, such as large FPGAs, in the boards is very difficult and very seldom works. A maintenance programme based on replacement of the broken SoM products, with moderate costs, will be built.

Documentation

Documentation will be available for future needs, i.e. maintenance, operation, test, etc. Besides, this information, including user manuals, repairing manuals, technical descriptions, CAD files, VHDL codes, software, should be placed in a computer space publicly accessible to all members of the collaboration. This place will be setup making

use of the AGATA collaboration space or in a different place if it's judged convenient.

Activity	FTE	Institute
DIGIOPT12 Board Maintenance	0.2/year	INFN-Milano
PACE Board Maintenance	0.2/year	Uni. Valencia IFIC
STARE Board Maintenance	0.2/year	IJCLAB
PSU Board Maintenance	0.1/year	Uni. Valencia IFIC
Mechanics Production and Maintenance	0,1/year	IFIC Uni. Valencia
System Integration and Installation	0.1/year	Uni. Valencia IFIC, IJCLAB, STFC, IPHC
Firmware Installation, Updates and Maintenance	0.2/year	IPHC IJCLAB Uni. Valencia IFIC STFC
Monitoring, GEC, Data Flow Software, Installation, Updates and Maintenance	0.1/year	IPHC IJCLAB STFC

Efforts required for the Installation, maintenance and upgrade of the Phase 2 Electronics

Pulse Shape Analysis and Characterisation for AGATA Phase 2

Introduction

The large volume highly-segmented HPGe crystals that form the core of the AGATA spectrometer, require the use of Pulse Shape Analysis (PSA) and γ -ray tracking in order to realise the performance necessary to deliver the key physics goals. Effective γ -ray tracking and the subsequent suppression of events that do not deposit their full energy in the array, require localisation of individual interactions within the detector volumes with spatial resolution on the order of a few millimetres. This is achieved by combining segmented detector technology with pulse-shape processing to localise interaction points with sub-segment resolution.

When a γ -ray interacts within the crystal volume it produces a charge cloud of electrons and holes, which drift under the influence of the bias voltage toward the central electrode and the segmented electrode, respectively. The motion of the charges induces signals on the core channel and on multiple segments. For a given γ -ray interaction point one segment collects the net charge (energy) deposited while neighbouring segments record transient (image charge) signals that return to zero after the charge collection time. The net segment energy deposition allows the location of the γ -ray interaction point to within the volume of that specific segment, with a precision of several cubic centimetres. However, by exploiting the detailed shape and magnitude of the induced signals on the neighbouring segments, which depend on the exact location of the deposition of energy in the segment volume, it is possible to locate the interaction point(s) inside the crystal with sub-segment (few millimetre) precision.

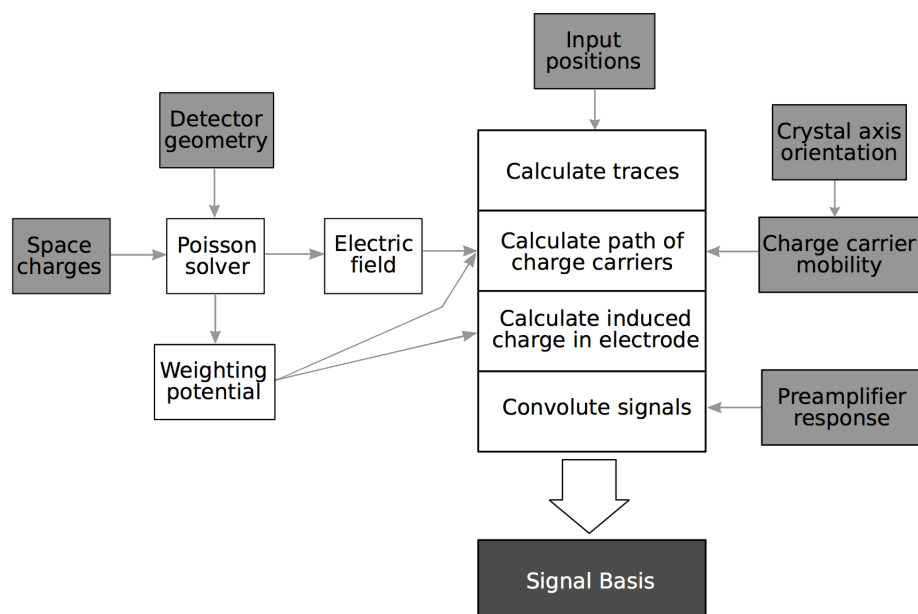

The AGATA Data Library methodology for basis generation

The implementation of Pulse Shape Analysis of the signals acquired with the AGATA array relies on the simulation of the electronic signals resulting from a γ -ray interaction point in a given position within the crystal. The corresponding pulse shape database is obtained by considering the drift of charges deposited on a grid of points which span the detector volume utilising the AGATA Data Library (ADL) code [Bart Bruyneel and Benedikt Birkenbach IKP (Eur. Phys. J. A (2016) 52: 70)]. The methodology used to calculate the pulse shape database (signal basis) for each detector type is shown schematically in the previous figure. The grey boxes indicate the key input parameters required by the code to enable a reliable basis to be produced. These parameters include the geometrical shape of the detector, the impurity gradient of the crystal, the crystal axis orientation, information on the mobility of the charge carriers and the pre-amplifier response function. Cross talk correction (both integral and differential) is then subsequently applied. The optimisation of these parameters is achieved through comparison (validation) with experimental data both through a programme of detector characterisation and in beam measurements.

The AGATA collaboration has a well-defined experimental detector characterisation methodology, this is used to generate the experimental validation data through detailed “coincidence scan” measurements of known single interactions at precise locations within the detector volume. The collaboration has established a number of sites where these measurements can be performed. This includes the University of Liverpool, IJCLab Orsay, IPHC Strasbourg and the University of Salamanca. These partners have worked to optimise the characterisation methodology and have developed new techniques based on both electronic collimation and the novel Pulse Shape Comparison Scan method. The latter provides the opportunity to measure a very large number of points within the detector volume in a much shorter period of time. The full validation of this method is currently in progress.

With a realistic set of basis signals PSA is reduced to the task of fitting the waveform data, event-by-event, with the best possible linear combination of basis signals. The PSA algorithm developed and implemented for AGATA Phase 1 is based on an Adaptive Grid Search (AGS) approach using a simplified single interaction per segment approximation. This has been well established within the collaboration and has yielded reasonable performance which has enabled the success of the AGATA Demonstrator and AGATA Phase 1 campaigns.

Upgrade/Plans for Phase 2

The physics goals of the AGATA Phase 2 campaign will require improvements to the performance, both capability and computational, of the AGATA PSA algorithm. PSA is the most computationally intensive aspect of the AGATA computing system, and thus drives the processor requirements. However, PSA is also a parallel process carried out at the individual crystal level, allowing a relatively straightforward architecture with multiple independent processing nodes.

The existing PSA algorithm uses a simplified single interaction per segment approximation while allowing multiple segments to be considered within a crystal. The algorithm also uses a crystal level calculated signal basis which has been optimised throughout the Phase 1 of the project in an attempt to maximise the performance of the PSA. The crystal level single hit pattern of determined interaction positions and the subsequent results from the Gamma-ray Tracking algorithm indicate improvements are required at the level of the PSA. For example, clear (non-physical) clustering of interactions is noted within the full crystal volume. This can only be explained if something is not correctly described in the calculated basis. The resulting Peak to Total and efficiency achieved using this basis is subsequently below what would be expected from pure simulations.

The computation performance of the algorithm(s) needs to be optimised to run on highly parallel, multi-core nodes. The existing algorithm is limiting the count rate capability of AGATA Phase 1. In moving to AGATA Phase 2 the algorithm(s) will be optimised to adapt to the new platforms and to allow flexibility in basis format, PSA outputs, and pre-processing options. Further, to take advantage of the performance gains provided by massively multi-core processors these routines will need to be vectorized and multi-threaded.

In order to improve the capability performance of the PSA a number of improvements are proposed.

- (1) An investigation of the dominant factors limiting the performance of the calculated basis is needed. This would include:
 - a. An evaluation of the impact of the temperature dependence of the mobility parameters,
 - b. The impact of a realistic charge cloud size,
 - c. Crystal dead layer related effects – the dead layer around the core electrode,
 - d. Neutron damage limitations – how the degree of neutron damage influences the efficacy of the signal basis in addition to the energy resolution correction already implemented,
 - e. The impact of the electronics signal chain (pre-amplifier grounding/configuration).

These impacts will be evaluated by performing a comprehensive set of experimental characterisation measurements to optimise the computed basis (for example full scans or pencil beam measurements) and a set of in-beam measurements to evaluate the impact on the resulting position resolution achieved. Necessary changes would then be made to the ADL signal basis used by the PSA algorithm to identify interaction locations.

- (2) Experimental characterisation of AGATA detectors will continue. This will include as a minimum the detailed characterisation of a subset of capsules and

²⁴¹Am scans of all new capsules to determine the crystal axis orientation, an essential input parameter for the E-field simulations.

- (3) The implementation of the existing AGS algorithm will be optimised for performance throughput. This work will include the potential addition of the export of PSA position uncertainties from the AGS algorithm to the Gamma-ray tracking algorithm. This will could allow performance improvements in the gamma-ray tracking.
- (4) The PSA algorithm will be upgraded to include the handling of multiple interactions in a segment. The performance of this algorithm will be evaluated and implemented for Phase 2.
- (5) An exploration into the use of other (non AGS) PSA algorithms for future implementation will be undertaken. The focus is on the possibilities available using Machine Learning and Topological Data Analysis. This task will build on initial work that has started within the collaboration.
- (6) Experimental Validation of a Method of AGATA Self-calibration. To improve the position resolution, a novel method for generating a reliable signal basis in a simple experimental way, utilising the self-calibrating capability of such arrays [Heil, Paschalis, Petri, EPJ A 54 (2018) 172] is proposed. This approach will be studied in detail.

For the next phase of AGATA, it is expected that the primary experimental data for physics analysis will be stored in the post signal PSA/GRT format of γ -ray interaction points and energies. However, the option to output and store waveform data is also required, for example, to enable debugging and testing of PSA and tracking algorithms.

Costs & Efforts

New PSA Farm

The existing AGATA PSA farm will need to be upgraded in order to deliver the performance required for AGATA Phase 2. The dual requirements of improved throughput and increased capability in the PSA algorithms make this an essential requirement. The PSA processing will also need to benefit from intelligent use of external triggering in order to improve the efficiency of the trigger validation process.

For the existing AGS and the implementation of the multiple interaction per segment algorithm a CPU based architecture will likely provide the optimum solution. The AGS algorithm requires 10ms per crystal on the existing hardware, the more computationally expensive multiple interaction algorithm requires 10ms per crystal to process the data based on a 2016 Xeon core. Assuming a conservative 4kHz per crystal post trigger this implies 40 cores per crystal or a 7200-core farm for the full array of 180 crystals. The

alternative, less mature, future algorithms based on a machine learning approach will benefit from a GPU based architecture. This solution will be investigated as part of the continuing R+D. Details on the proposed architectural solution and costing for the non-GPU phase of the project can be found in the following data flow subsystem section.

The implementation of the improvements to PSA will need to be staged. The optimised existing AGS algorithm could be implemented on the existing farm and also used to prototype the new architecture. The more advanced multiple interaction algorithm could be implemented with limited performance on the existing architecture but would realistically require the improved computation performance facilitated by the new architecture. The proposed solution for this can be found in the follow Data Flow section of this document.

Effort

- The improvements to the PSA basis and associated optimisation of the input parameters will require the AGATA detector characterisation team to coordinate a series of measurements of AGATA crystals. The data collected will be analysed and compared. This will require 4 FTEs of physicist effort and 2 FTEs of technical support.
- The continuing characterisation campaign for new detectors will require a further 2 FTEs of technical support and 2 FTEs of physicist effort.
- The performance optimisation of the PSA algorithms will require software engineers with oversight from physicists to ensure the end user requirements are met, this will require 4 FTE of software engineer support and 2 FTE of a physicist.
- The new PSA algorithm work will require the effort of both Physicists and software engineers. The implementation and optimisation of the multiple interaction algorithm will require 4 FTE of a Physicist and 1 FTE of a software engineer.
- The investigation of other PSA algorithms and machine learning approaches will require 4 FTE of physicist effort.
- The validation of the self-calibration methodology will require 3 FTEs of physicist effort.

The implementation of the optimised solutions within the AGATA data flow architecture is separately discussed with effort summarised in the next section.

Commitment

The detector characterisation work will be supported by commitments from the University of Liverpool, IPHC Strasbourg, IJCLAB Orsay, GSI Darmstadt, IKP Cologne and the University of Salamanca.

The PSA including the machine learning work will be supported by the University of Liverpool, University of York, GANIL, IJCLAB Orsay, CEA Saclay, IPHC Strasbourg, GSI Darmstadt, IKP Cologne and the University of Salamanca.

The consortium of University groups and National Laboratories will endeavour on a best effort basis to support the planned work. Effort will come from staff scientists, software engineers, post-doctoral researchers and funded PhD studentships.

Tasks, estimated milestones

- PSA/Characterisation: The improvements to the PSA basis and associated optimisation of the input parameters (Q4 2022)
- PSA/Characterisation: The continuing characterisation campaign (ongoing)
- PSA/Characterisation: The performance optimisation of the PSA algorithms (Q3 2021)
- PSA/Characterisation: New optimised multiple interaction PSA algorithm (Q4 2024)
- PSA/Characterisation: The investigation of other PSA algorithms (Q1 2025)
- PSA/Characterisation: Experimental validation of a novel self- calibration method (Q4 2023)

AGATA Data Flow and Data Processing

Introduction to the Data Flow Subsystem

This section specifies what is presently being used for the AGATA Data Flow subsystem and what is required to complete Phase 2 in terms of new developments, cost and FTE.

The data flow structure (see figure below) was originally designed for the LNL Demonstrator phase operation and this architecture, which is presently working at GANIL, is as also the foundation to build the Data Flow for the phase 2 of the project.

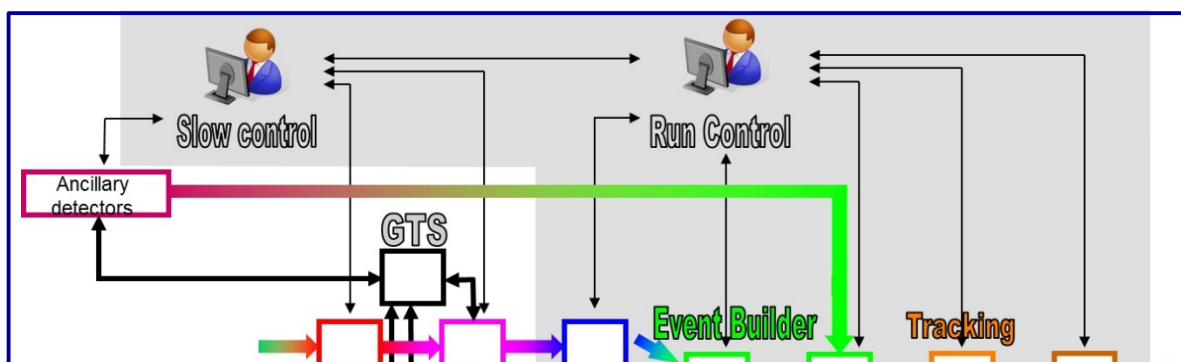

Block diagram for the data Flow structure for Phase 0, phase 1 and beyond.

The system is based on a set of coordinated processes of 3 kinds: Producers (handling incoming data), Intermediaries (filters, mergers, ...) and Consumers (data storage into files, histograms, ...).

The computing infrastructure deployed for AGATA Phase 0 and Phase 1, for the experimental campaigns at LNL, GSI and GANIL, consists of:

- one computing node per crystal to readout the data from the pre-processing electronics and to perform the Pulse Shape Analysis,
- one Cluster of computing nodes for event building, merging and tracking,
- a set of common nodes for the Run Control, Disk Server, SRM (Storage Resource Management -i.e. data transfer to grid), Slow Control, Data Analysis, spares ...
- disk servers for raw data and for backup,
- network switches,
- visualization workstations for both the experiment control and the online Data Analysis,
- data Analysis servers.

The current infrastructure of the data flow, in the present (2020) installation of AGATA with 45 capsules (1π), is composed of:

- 45 acquisition servers,
- 1 cluster with 3 servers for event building, merging and tracking,
- 1 CEPH cluster with 168 TB available @700 MB/s (5 OSDs, 3 Monitors, 1 RBD client),
- 1 backup server with 50 TB available (for quick recovery in case of failures)
- Local GRID server for data transfer
- 8 network switches,
- 5 visualization workstations,
- 4 analysis servers,

Data flow software infrastructure

Beside this infrastructure, one must also consider all software packages needed for data transport, algorithms integration, system and hardware control, graphical user interfaces, slow control system (see Electronics section), system backup as well as for providing interfaces for data analysis.

Within AGATA Phase 1, the first installation of the Data Flow hardware and software were completed in April 2012 and, since then, improvements and tests have been performed continuously. The Data Flow software and hardware have shown to be stable and successfully performed during the AGATA-PRESPEC campaign and they are still doing so for AGATA@GANIL campaigns.

In 2019, the initial NARVAL Data Flow software was largely rewritten and this upgrade corresponds to the birth of the DCOD/NARVAL version. This upgrade not only increased the bandwidth but is also the key for the implementation of AGASPY (see below for details).

Several services are needed to control and monitor the whole system including the electronics in consistent way. The Topology Manager (TM) is the key to insure this complex task.

The Data Acquisition-box structure at GANIL is illustrated in the figure below. It includes:

- GEC, Global Electronics Control for the whole AGATA system,
- GCC, Global Control Core acting as a bridge between the AGATA systems and the other environments (ancillary detectors and spectrometers such as VAMOS). Its primary function, for each experiment consist of: the preparation of directories with the needed configuration files, the dispatching of the hardware information into the corresponding configuration files and ensuring the coherency between the configuration files and the multiple parameters of the system,
- RCC, Run Control Core for the ancillary readout and data processing for both AGATA and ancillary actors,
- DCOD/NARVAL actors including the Event Builder, Merger, Tracker and storage,
- Topology Manager (TM).

It is worth noting that the Run Control Core is versatile and we have been using different ones depending on the host laboratory of AGATA. However, the core structure, described earlier, will be embedded in the Phase 2 setup with some upgrades that will be described below.

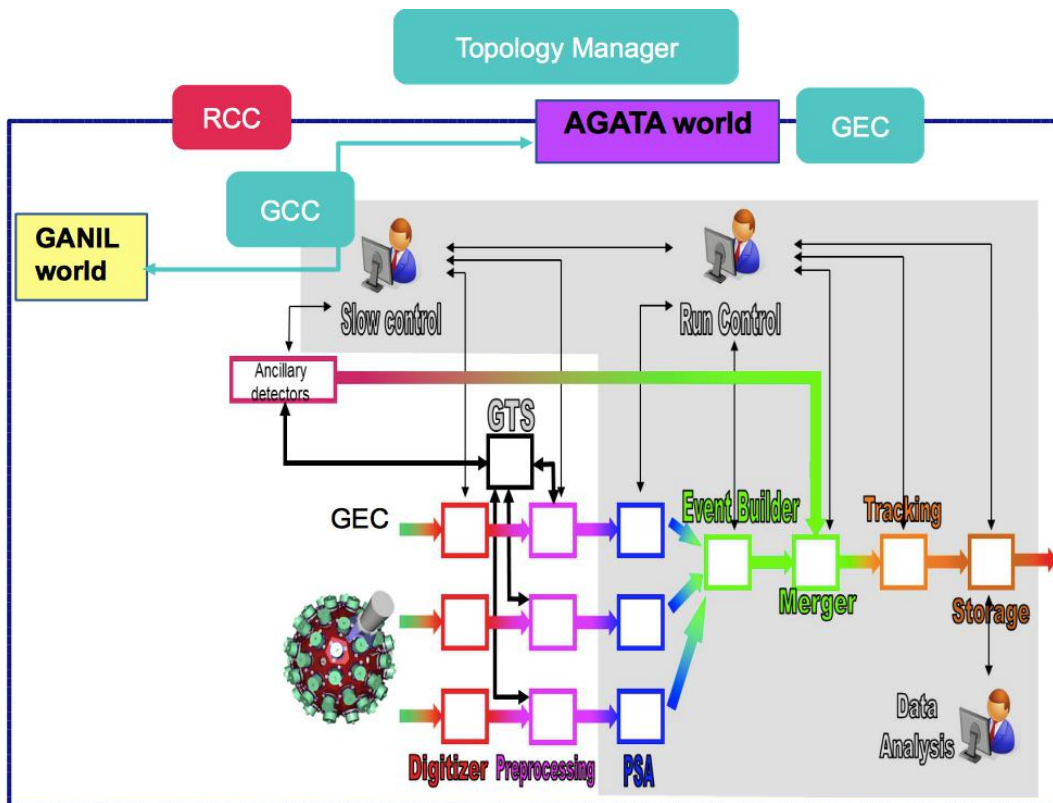

Block diagram for the Data Flow Structure at GANIL

Global Electronic Control (GEC)

The GEC, presented in the figure below, provides a global control of the whole AGATA electronics.

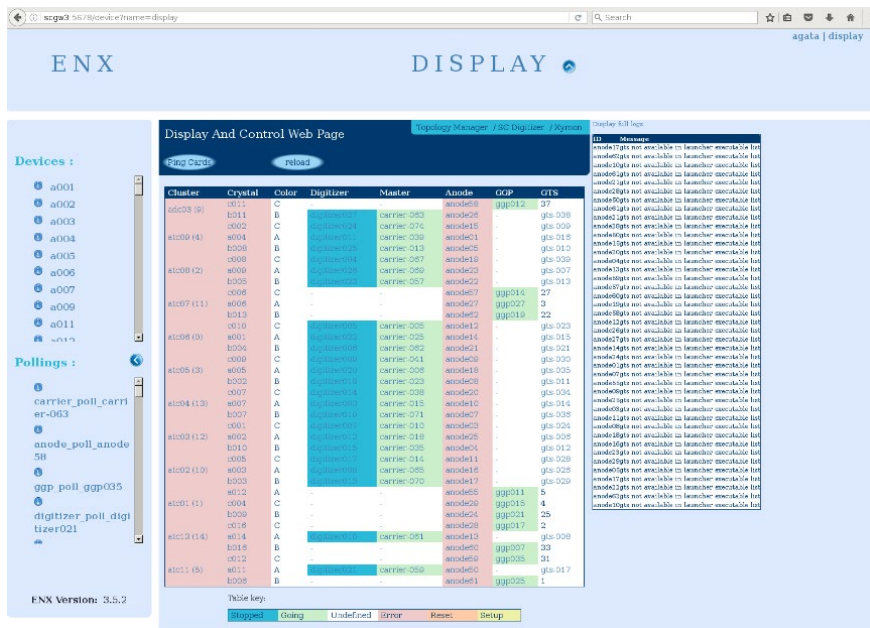

General layout of the GEC

Each sub-electronics system (digitizers, pre-processing) is controlled by a dedicated software that offers high-level fine-tuning options. It also provides access to specific interface, when needed, with a global view of the system at all time. An example of GEC functionalities is displayed in the following figure.

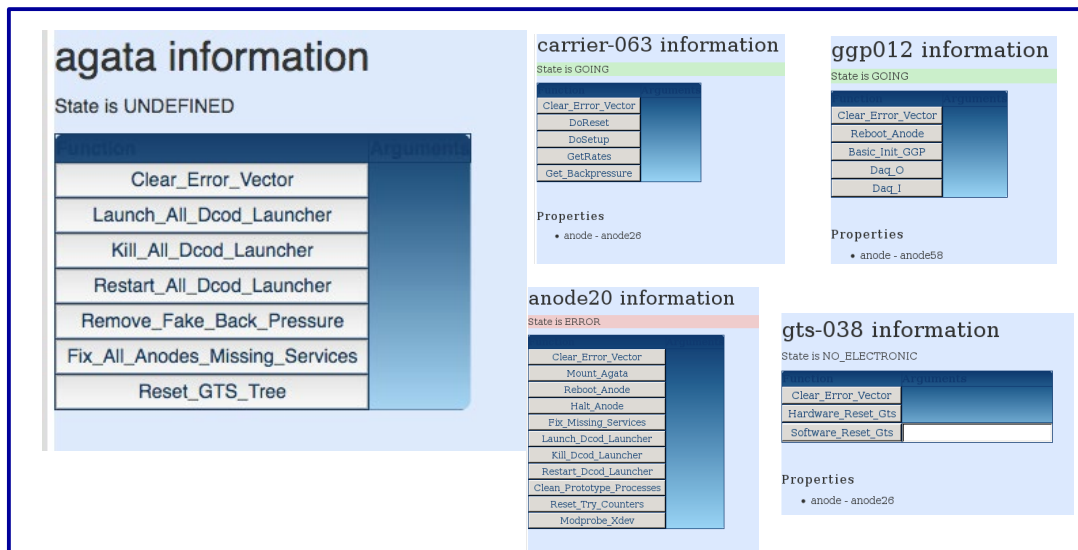

Example of functionalities of the GEC including the electronic and server status

Note that this global view is achieved in the framework of crystal-by-crystal (and channel-by-channel) basis, and hence, the GEC can be seen as a master of a superposition of different layers of specialized/dedicated tools.

Topology Manager

The Topology Manager (TM) is a major development in the data flow.

The task of the TM is to insure coherency and stability of all configuration files used by electronics sub-systems as well as the coherency of the algorithms used in the whole system in real time. The TM shows the status of the overall system: it includes the electronics version information of the various channels and the identification tags or numbers with the correspondence between the different labels (as for example the electronics channel number versus the crystal name or label).

In other words, the generation of the configuration files and the topology of the experiments is performed via the TM which includes the entire hardware list and relations. This is illustrated for few crystals in the figure enclosed below, where one can see the activated hardware in green and the non-activated one in yellow.

Note that the activation or de-activation can be performed from the web interface (as seen in the GEC) or by command line commands.

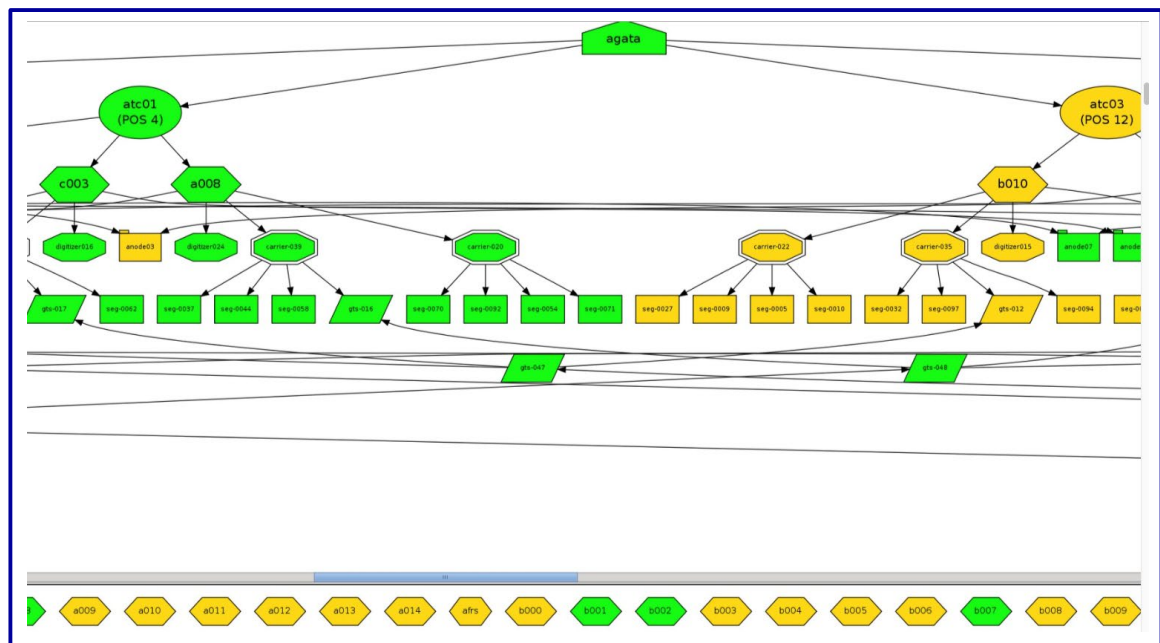

Example of activation tree in the AGATA TM

Software distribution

Ensuring software versions are unique, support of different distribution versions and accept multi Linux distribution are some of the important tasks of PEM (Project Environment Marketplace). Inside the AGATA Data Flow infrastructure, we have to manage at least Debian, Ubuntu and CentOS operating system distributions with, at this moment, 4 different releases of Debian distribution. When deploying a new version of some part of the infrastructure software, it's important to make sure that all has been correctly compiled and that all computing nodes are set with the same version of the program. These features prevent from any data flow corruption.

Phase 2 Data Flow upgrade & challenges

The AGATA Phase 2 Data Flow system will continue to use the transferrable architecture of DCOD/NARVAL described above.

One of the main drawbacks of the current infrastructure comes from the constraint imposed by the electronics related to the PCI readout (see Electronics section): hosting the PCIx cards requires one server dedicated to each crystal. This strongly constrains the computation model and limits the processing capability.

Different computing models, depending essentially on the physics requirements, are being evaluated keeping in mind the variety of the instrumentation coupling and the AGATA high-counting rate capability. The future Data Flow design will be based on a different approach, including new-developed features, that are presented below.

With DCOD/NARVAL, memory access and network transmission are managed by dedicated modules: POSIX Memory Handler (PMH) and Common Transport Layer (CTL). Data management in the computer memory is no more embedded in the DCOD/NARVAL processes and this feature is well suited for the full AGATA as it will provide the required flexibility, modularity and robustness for the full array. In this way, it will be easier to optimize separate codes and to include new protocols in the system. DCOD/NARVAL and the associated PMH/CTL diagram is illustrated in the following figure for a general example of data distribution.

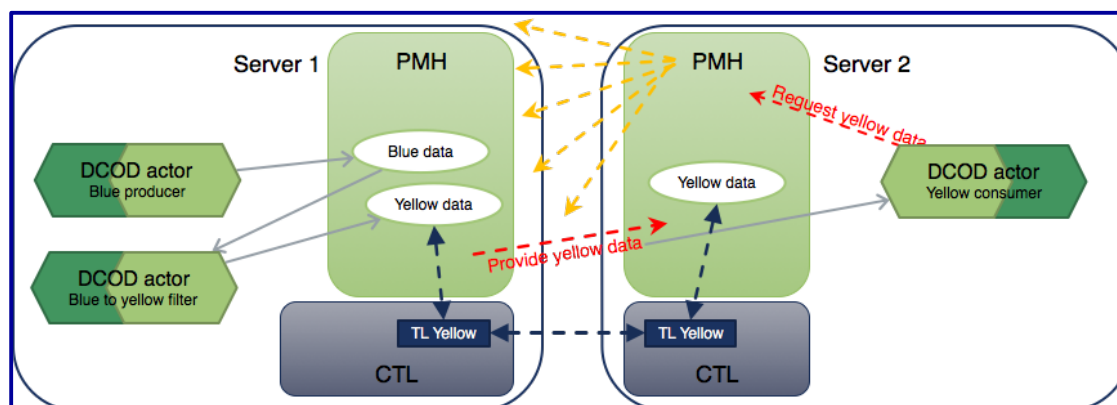

Example of data distribution with DCOD and the associated PMH/CTL

The Data Flow upgrade will be done in various steps according to the electronics evolution.

Improving PSA performance: event dispatcher and cache optimization

With today's algorithms and with future generation of processors, one should be able to process the PSA at 10 kHz /crystal with one Anode per crystal. But it's not possible to rely only on computing architecture evolution to reach this goal: some of the present limitations cannot be solved without deep optimization or large modification of the existing algorithm implementation. A balance of the PSA processing load can be considered, opening the possibility that different PSA algorithms can be used for different event complexities. Among all the possibilities, two options can be easily implemented:

Event Dispatcher:

For those PSA algorithms that perform better on single hits than on multiple hits, a first level filter can be set to dispatch data to the right algorithm farm and hence improve the performance. The proposed mechanism is displayed in the following figure.

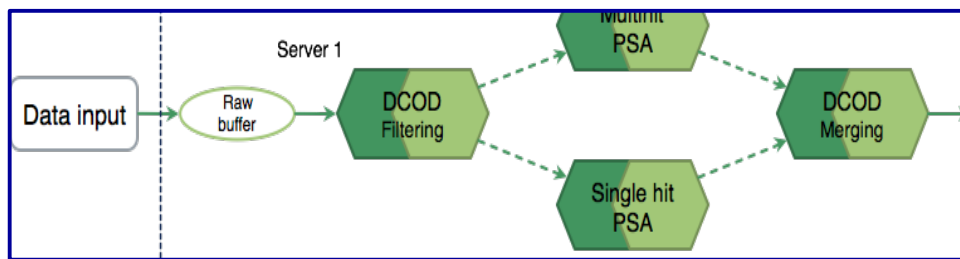

Event Dispatching using two different PSA algorithms

Cache optimization:

Another limit on the performance of the PSA in terms of rate is due to the memory access/cache that is constantly needed while running the current PSA. An innovative option could be based on splitting the PSA for a given crystal in 2 parallel tasks applied to 2 different sets of crystal slices (slices 1 and 2; slices 3 to 6).

The total hits in the front of a crystal (slice 1 and 2) correspond to 45% of the events while slice 3 to 6 correspond to 55% of the total events. Because of this, one can split the basis for the relative events and hence perform the PSA for the hits in slice 1-2 in one server and the rest in another one. Today's performance is limited to 4-5 kHz/crystal and the proposed method will allow a gain of factor of 2 for the data processing over the PSA. This is illustrated in the following figure for 2 crystals.

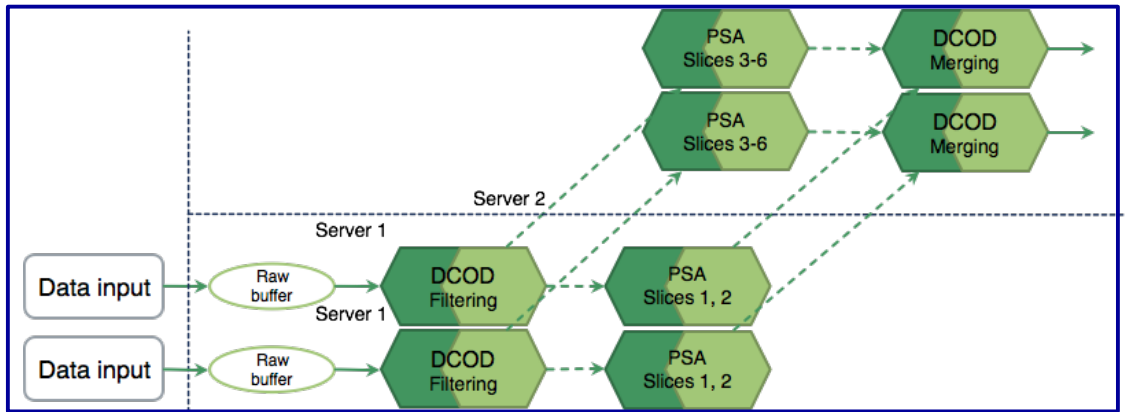

Schematic view of the PSA task over two sets of slices by splitting the basis

Data Flow upgrade with the new electronics (beyond 2025)

The Phase 2 electronics being presently designed is based on the scheme described in the figure enclosed below. As the new electronics boards readout will be based on ethernet, in other words, there will no more be point-to-point connections, the CPU-load will have the possibly to be distributed over High Performance Computer farms (HPC). In this case 1 node/crystal will not be necessary and new technologies could be implemented.

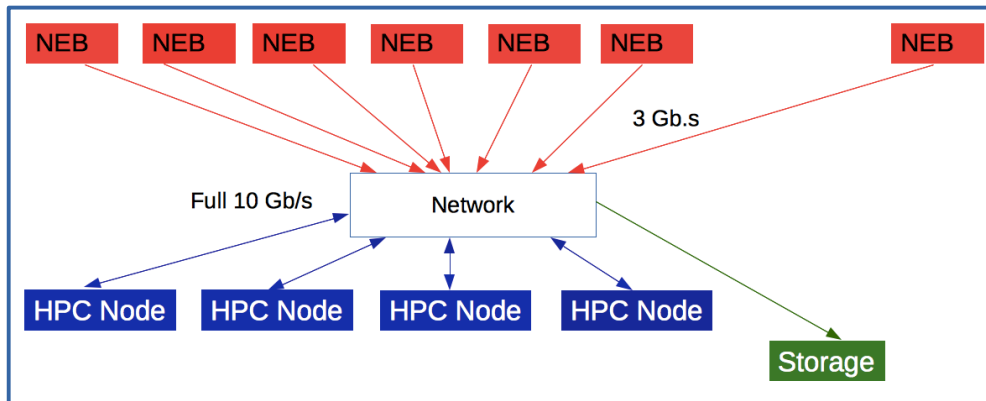

Possible Data Flow layout with the Phase 2 new electronic boards (NEB)

GPU optimization:

With such electronics, one can use a GPU optimization for an additional improvement of the PSA processing within the Data Flow-system. The corresponding scheme is shown in the following figure.

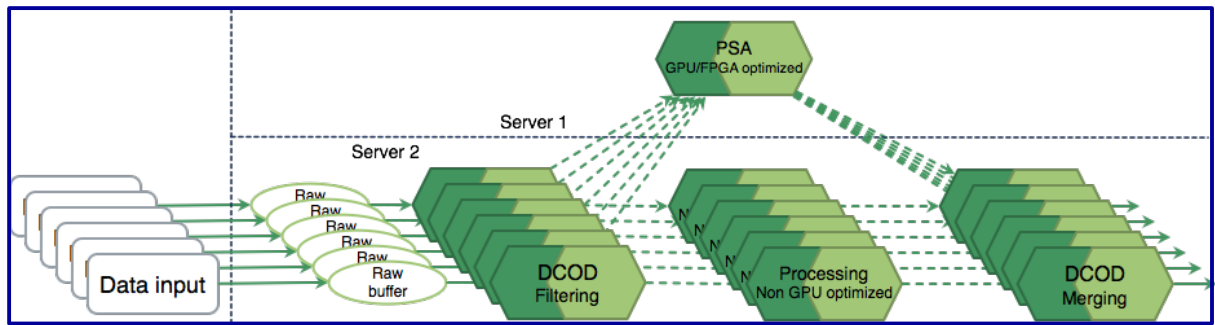

High performance computing farm sketch for the phase 2

It's worth noting that the implementation of new PSA algorithms, such as those based on machine learning (see PSA section), will require a GPU architecture.

Software trigger implementation

In the Phase 2 Data Flow upgrade, the recently developed software trigger (See following figure) will be implemented.

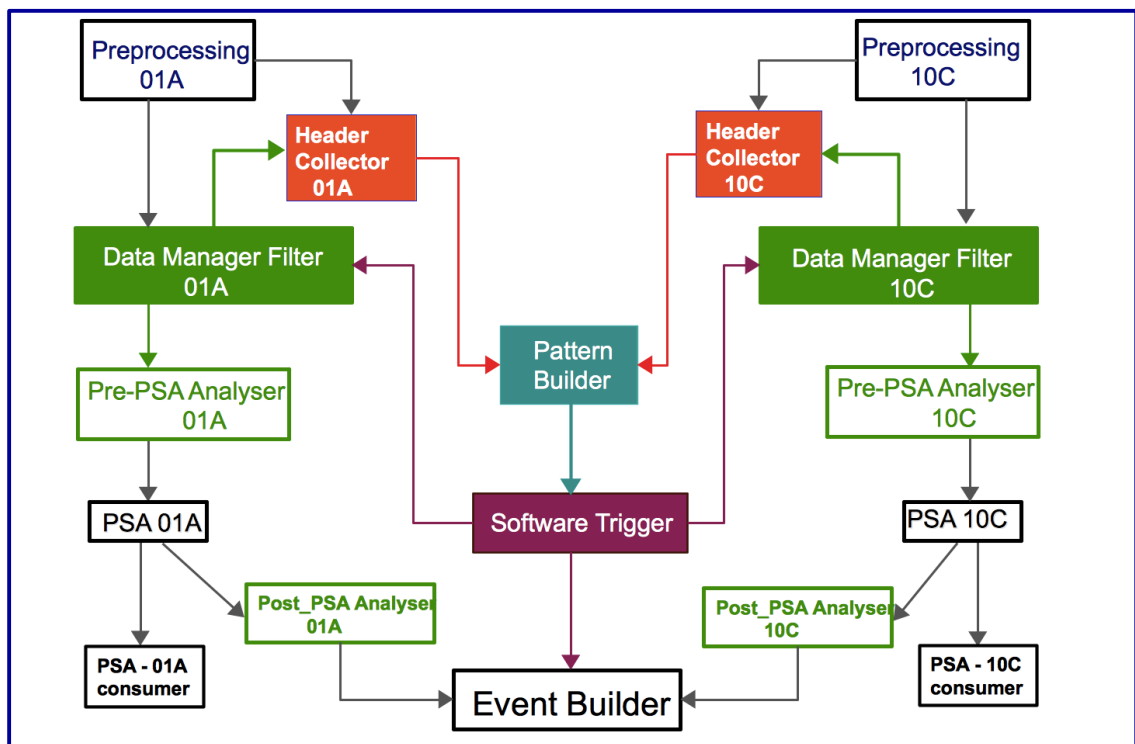

New Software trigger system block diagram

It represents a major achievement for the Data Flow. A third level trigger in the array will be necessary in order to be more selective and optimize the PSA processing load. The software trigger validates or rejects the pattern built by the pattern builder (depending on the trigger configuration requested by the physics goal) and provides all validations to the Event Builder. Three dedicated process have been developed in order to ensure the following specific tasks:

- The Header Collector extracts headers from the pre-processing electronics producer and performs a basic analysis of the flowing data from the corresponding crystal in order to provide the relevant information to the pattern builder,
- The Pattern Builder, while receiving these headers, builds a pattern composed of a list of crystals that fired in the same defined time window. These events are tagged and the resulting patterns are sent to the trigger, which in turns sends the information to the data management filter and to the Event Builder,
- Data Manager Filter (DMF) filters all the pre-processing electronics data while waiting for the trigger system status. If the trigger condition is fulfilled, the validation is sent to the Event Builder, otherwise the event is rejected.

Monitoring software upgrades

On-line spectra inspection is very important for prompt diagnostics of system performance and to ensure physics objectives are met. It becomes mandatory when the high counting rate prevents storing the raw traces. Automatic procedures need to be developed, when increasing the number of crystals in the array, in order to safely run the experiment with the proper warning, watchers and messages that should be promptly provided to the users.

A new tool called AGASPY has been recently developed using DCOD/NARVAL, to report any possible issue with the Data Flow (input/output, bit-swapping, missing channels, timestamp ordering ...) as soon as they happen. Although it is fully operational, it will be upgraded in order to include automatic procedures and further functionalities.

More information could be inserted into the data flow such as crystal failure, LN2 filling, with the corresponding warnings. Other features related to electronics monitoring (scope visualization, threshold and MWD parameter checking) will be implemented in collaboration with the Front-End Electronics working group. Without any doubt, machine learning techniques are to be added to the current tools to monitor a system producing a huge amount of data and meta data.

In other words, other improvements and upgrades that are connected with tasks from other working groups, will make the operation of the full array more robust. This will also require further personnel efforts.

Phase 2 Data Processing upgrade & challenges

Gamma-ray Tracking

A straight forward improvement of the tracking can be expected when the PSA will be able to provide errors on the interaction position and energy (especially when neutron damage correction is applied). Beside this, new developments, using hybrid algorithms

(Forward + Backward tracking) and machine learning technology, will be explored to improve tracking. The Compton-scattering formulae as well as the photo-absorption and Compton-scattering probabilities could be imposed as rules for the clustering machine learning procedure.

It has been observed that the application of forward tracking algorithm produces superior cluster quality when applied on simulated data as compared to experimental data. To overcome this problem Machine Learning is planned to be applied for clusterization. This new technology will also be investigated for the treatment of pair-production events. Moreover, it should be possible to use it in recognition pattern for the full or partial absorption which will result in a further improvement of the peak-to-total ratio.

We know, from previous developments, that Fuzzy logic is useful for problems that are well described, but it is complex and it becomes more complex when there is noise or uncertainties affecting the data, therefore developments using such technique is unlikely an avenue .

Data analysis:

The data analysis software structure is quite complex and a lot of efforts have been and will still be devoted to further developments and improvements. The variety of tools and developments can be seen in the structure of the data analysis software layout displayed in the following figure.

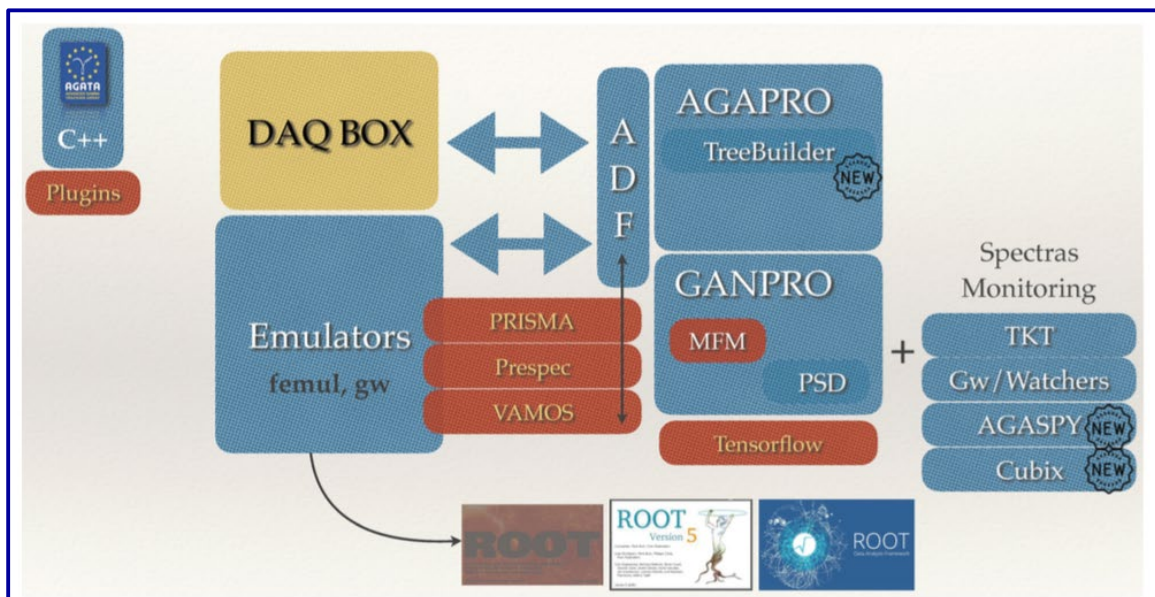

Layout structure of the AGATA Data Analysis Software

As expected, documentation is of paramount importance. An existing documentation (web site link : <http://agata.in2p3.fr/forum/viewforum.php?f=3>) provides a guide to help the users analyzing the AGATA data produced at the local level processing, i.e.,

before any building of events has been done. It includes the traces, energy and time calibrations, alignments, cross talk corrections and any other corrections to improve the quality of the data. This procedure will be used for Phase 2 with possible improvements as for example the implementation of a faster and automatic way to perform the data analysis.

Furthermore, with the advancement in the construction of AGATA, it should be possible to exploit the full potentialities of the γ -ray tracking.

A new software, Cubix, is now available in the GammaWare package. With Cubix, it is possible to perform the data analysis in the ROOT environment (for the moment only with 1D and 2D spectra). Presently coincidence conditions on $\gamma\gamma$ matrices can be performed with background subtraction. However, with a larger array one has to improve the tool in order to perform data analysis with higher fold coincidences, as is done today with the 3D and 4D cubes in the different analysis software (Radware, Xtrackn).

Moreover, one would be able to measure entry distributions and perform the γ -ray quasi-continuum analysis, with better accuracy than was possible with the previous generation of escape-suppressed detector arrays. However, the techniques for doing so may represent a challenge for γ -ray tracking arrays, since unfolding the data for the quasi-continuum analysis requires the construction of the proper response function. These techniques are being developed within the AGATA-GRETINA/GRETA collaboration.

Data re-processing, distribution and storage:

Currently, raw data produced during the experiments are stored on the GRID in two different TIER1 centers, CCIN2P3 Lyon and CNAF-INFN Bologna. The storing process is duplicated for security reasons in case of failures or losses of one of the TIER1 centers. The GRID itself is seldom used to re-process the data and, hence, the users usually download their data to local storage where they can run emulators able to manage part or the full data processing, in the same way as it is done online with DCOD/NARVAL. In fact, while the data processing for AGATA is possible on the GRID, the difficulties with the access to the infrastructures and the particularities of the GRID software have prevented its more extensive use for our analysis, even if the time-gain on replaying the PSA analysis has been shown to be quite sizable. New technologies, i.e. iRODS, are foreseen as future solutions and can be investigated. The chosen solution should also allow efficient and user-friendly re-processing on dedicated infrastructures.

Because of the increasing number of capsules and higher counting rates, the storage of raw traces needs to be avoided as much as possible: it becomes simply impossible for experiments with high γ -ray multiplicities. However, there might still be experiments for which raw data can be stored at the trace level. This would be interesting, for instance, for developments of PSA algorithms whether linked or not with higher processing levels. Indeed, there are ideas to use tracking algorithms as a constraint to

better identify interaction points in a crystal. As well, through machine learning techniques (deep neural networks), a possibility could be to fill the network with the traces of all the detectors and to get as output the tracked γ -rays. Such developments require high computing resources offline. It should be noted also that the current software solution to replay the data which run on single computer (such as femul emulator, GammaWare or NARVAL standalone version) are clearly, as such, not adapted. We do need to set up more advanced solutions adapted to the computing infrastructures to come: virtualization, containers, cloud technologies and heterogeneous hardware (GPGPU / FPGA). Whatever the chosen solution, it should stay suitable for online processing within the current Data Flow infrastructure.

Note that even without traces, data replays (for instance for re-building, re-merging + tracking) could be a long process as we experienced during the NEDA + DIAMANT campaign at GANIL. A faster analysis will become necessary but it represents a real challenge.

Data Management and Policy

The AGATA collaboration commits to implement, as soon as it is available, a Data Management Program (DMP), as part of Open Science, as soon as Nuclear Science discipline-specific research data management or Nuclear Science domain data protocols are available.

In the meantime, the AGATA Data Policy (approved by the ACC and ASC in 2010) as well as the specific Host Laboratories Data Policies, will be followed.

Cost estimates, efforts and schedule

The network infrastructure needs to be scaled according to the number of crystals.

A cost estimate can be only tentative, since the processor price is subject to fast and unexpected market fluctuations. In addition, the cost is much lower if the order is grouped on a large number of units. A first cost estimate for Phase 2 of Data Flow, PSA, Tracking and Data Analysis is given in the following table.

Cost estimate as for 2020:

New hardware	90 crystals 2 π	135 crystals 3 π	180 crystals 4 π	Cost/unit k€	Total Cost k€
Servers/crystal	90	+90	+90	3	810
switch/20	6	6	8	3	60
backbone switch	1	0	1	5	10
EB, Merge, Tracking	3	3	4	3	30
Data Flow servers	5	5	5	3	45
CEPH upgrade	7	7	7	15	315
CEPH monitors	5	5	5	1.5	22.5
Analysis machines	2	2	2	5	30
Phase1 upgrade (servers)	45			3	135
	605,5	465,5	479		
Total					1457.5 k€
Total (including cables)					1550.0k€

Column 3 (4) indicates the costs to be added to reach 135 (180) crystals starting from the 90 (135) crystals configuration.

It considers adding crystals, from the 45 presently used at GANIL up to 180, assuming also an upgrade for the processing capability to 2 servers per crystal for the PSA processing.

For the racks and cooling infrastructure, see the Infrastructure section.

Efforts needed and schedule:

<i>14 FTE including physicist, engineers and post-docs.</i>	
Data Flow	4.5 FTE
Data Flow Developments	3 FTE for 3 years from now on
Data Flow Maintenance	0.5 FTE
Network system admin	1 FTE
Tracking	3.5 FTE
Developments	3 FTE
Maintenance	0.5 FTE
Data analysis, re-processing and storage	4 FTE
Developments	3.5 FTE
Maintenance	0.5 FTE
<i>At least 2 post-docs for 3 years from now on will be needed</i>	

	2020	2021	2022	2023	2024	2025	2026	2027	2028	2029	2030
Current PSA (GANIL)	Yellow										
Current PSA (LNL)			Green								
Software Event Dispatcher For multiple PSA algorithms			Green								
Point-to-Point Readout Single Node PSA	Yellow										
Ethernet Dispatching PSA on HPC						Green					
ML tracking algorithms				Green							
New computing infrastructures for data re-processing and distribution				Green							

Schedule for the Data Flow and Data Processing for the Phase 2
(yellow: use of existing infrastructures and software, green: use of Phase 2 upgrades)

Maintenance and Commitment

It should be noted that hardware lifetimes are finite. If the machine lifetime may be of 5 years or more, the guarantee is of 3 or 5 years only (and the cost of an extended guaranty does not compete with supply replacing the machines). After this period, any broken machine or disk array has to be replaced. The performances of the system would anyway profit from any processor upgrade. It is therefore safe and valuable to replace all the servers every 5 to 7 years.

The collaboration, IJClab Orsay and IP2I Lyon, should be able to perform the developments and upgrades mentioned in this section with the human and financial resources that are necessary

Detector Infrastructure Subsystems

Introduction

The AGATA infrastructure consists of several items that constitute the Detector Support System (DSS). The present DSS is ready for a setup with 15 ATCs at GANIL.

Some items are obsolete and built with now discontinued components. Important upgrades are in progress. These developments will use modern components to build (backward compatible) modules for an array of 30 ATCs with the possibility to easily extend the production for a configuration of 45 or 60 ATCs.

The extension of the array to 30 (2π), 45 (3π) or 60 (4π) ATCs will require the production of new LVPS crates and modules, an upgraded LN₂ detector filling system, the purchase and installation of a new HV system, and the production and installation of additional sets of cables, like those developed and produced for the Phase 1 of the project. The EMC will be tested and improved when needed.

The implementation of an array with 20 ATCs, as given in the AGATA Phase 1, will use the first upgraded crates and modules as an intermediate step toward the full array configuration.

The DSS system consists of:

- **Low-voltage power supply (LVPS):** each unit powers 111 HPGe pre-amplifiers, 3 digitiser front-end electronics for one triple cluster (ATC) and the Profibus. At present, 18 first generation crates and modules are available.

A new upgraded version is under development with improved characteristics: more compact and with lower power dissipation in agreement with the characteristic of the new V1 and V2 digitizers (DIGIOPT12, see Electronics chapter). The project is the result of the collaboration between the Axis Company and the Irfu, France. The new LVPS crates and modules will be produced by Axis.

- **High-voltage:** a commercial CAEN HV system is presently used. Two SY527 mainframes and 10 A832P cards (12 channels with individual enable) are available from GAMMAPOOL loan. The system can power up to 120 channels, including spares. All components are more than 20 years old: they are now discontinued, and the repair may be problematic. This high-voltage system cannot be integrated in the DSS control system.

A new system is necessary to power up to 135/180 channels. Two solutions (CAEN SY4527 mainframe + A1560H boards or ISEG crate + EHS 8260P boards) have been tested. Performance differences are marginal, and both systems represent a valid long-term solution that could be easily integrated in the DSS control system.

- **LN₂ detector filling system (Autofill):** the present autofill system has been developed and produced by GSI. It is composed of 3 groups of modules (Profibus Crate, Valve Control Crate and Valve Power Supply) and each group is capable to manage up to 8 detectors. It can be used to keep a maximum of 24 ATC detectors (cryostats) at liquid nitrogen temperature. The system uses 2-wire connection to monitor the temperature of one PT100 in each cryostat and requires external PLC cards to read the second PT100 and the LN₂ level card in each detector. The control and command processes are running on an industrial PLC. An additional PLC unit is available as spare. The Graphic User Interface (GUI) and the PLC processes are based on MUSCADE, a set of tools, libraries and applications developed at Irfu, France. The LN₂ filling system is connected to a phone dialer to notify the occurrence of alarm conditions.

The upgrade necessary for 30 ATCs has already been defined: the project has been developed by Irfu, France using modern PLCs, hardware and software components. The configuration will be based on industrial items and will include 2 identical groups with 16 detectors each. Additional parameters will be monitored with improved performances as requested by the AGATA Detector team. The system can be easily extended to operate 45 or 60 ATCs. The GUI will handle both the LVPS and the autofill systems using the Profibus communication protocol. The open source EPICS environment will substitute the MUSCADE proprietary development framework.

- **Cables and patch boxes:**

Cabling is presently available for 45 capsules:

- Cables:
 - LVPS cables ($\pm 6/12V$, 48V, 5V): produced by Irfu, RCE and Axis companies;
 - HV cabling: collaboration;
 - Profibus network: produced by Irfu and FORCLUM company;
 - Pre-amplifier to digitiser MDR cables: industrial product;
 - Optical cables from digitiser and pre-processing cards: industrial product.
- One patch box per detector (ATC or ADC) with LV ($\pm 6/12V$) distribution to the capsules and LV filtering, Bias Shut Down (BSD) and LN₂ level monitoring boards. The box is attached to the Dewar.
 - 21 patch boxes are presently available. They have been produced with LV filters (Irfu, MKM and Axis companies, Strasbourg), BSD (GSI) and LN₂ monitoring boards (IKP-Cologne). Adjustment of the LN₂ monitoring card is done by the Detector Module working group.
- **EMC:** The Infrastructure Team is in charge to qualify the global grounding of the array; qualifier IJCLAB, France.

Upgrade for Phase 2

LVPS

The eighteen units of the first generation can be used with V0, V1 and V2 digitizers and cover the needs of 15 ATCs + 3 laboratories for tests (Axis and Irfu, France and detector development at IKP, Germany).

The upgrade is compatible with the lower power consumption of the V1 and V2 digitizers and satisfies the stronger space constraints of the evolving array. Moreover, it reduces the LVPS cost per ATC by a factor of 2. Only $\pm 6/12V$ and 48V power supply will be necessary. The LV modules for 8 ATCs will occupy two 8U high crates: one including eight 48V modules and a Profibus Controller and one including eight $\pm 6/12V$ modules and a Profibus Controller. This could allow to separate the 48V modules from the 6/12V modules and reduce the space needed close to the array, if necessary.

Eight crates are necessary for an array of 30 ATCs (90 capsules + 6 spares) and another four crates for each extra group of 15 ATCs.

Two “standard” 47U cabinets (2.1 m high), placed close to the array, will host the crates with the $\pm 6/12V$ and 48V modules for 30 ATCs, and another cabinet will be needed for each extra group of 15 ATCs. Additional fans installed in each cabinet will guarantee sufficient air circulation. In harsh environment, external air conditioning must be considered. An extra system of two crates with one of each module types is needed at Axis or Irfu and will be available as spare.

Preliminary cost estimate:

for the first module (8 ATCs): 60 k€,

for next modules (8 ATCs): 36 k€ (up to 20% discount for volume production) and 18 k€ for the additional system.

The total cost will be 186 k€ for an array of 30 ATCs (90 capsules+6 spares), + additional 72 k€ for each extra group of 15 ATCs.

HV

The replacement of the present HV system will be integrated in the DSS control system (software libraries available and standard USB/Ethernet communication protocol).

An additional module could be necessary to adapt the HV shutdown signal from the LN₂ autofill system to the HV boards.

Cost estimate (CAEN):

58.7 k€ for 30 ATCs (10.8 k€ Mainframe Full + 12x3.95 k€ A1560 Boards + 0.5 k€ for the signal adapter crate for the HV shutdown)

+ additional 29,5 k€ for the first extra group of 15 ATCs (5.8 k€ Mainframe Base + 6 x 3.95 k€ A1560 Boards)

+ additional 23,7 k€ for the second extra group of 15 ATCs (6 x 3.95 k€ A1560 Boards).

Autofill + PLC + Profibus DP network + cryogenic accessory items

The upgraded LN₂ filling system for 30 detectors (+ 2 spare channels) will use industrial components and is based on two identical groups of 16 detectors. Each group will be connected to an independent buffer tank of at least 300 l. In this configuration, each buffer tank will be refilled twice per day.

For an array of 45 or 60 ATCs, the configuration will include 3 or 4 of these buffer tanks, one for each group of 16 detectors. An alternative could be to use a large volume “external” tank with internal buffer tanks (at least 600 l) used only for emergency fill.

The system has been developed in view of the full 60 ATCs (+4 spare channels) filling. It will be integrated in one cabinet (2m high) for 30 detectors, with an extra 1/2 cabinet for each extra group of 15 detectors.

Cost estimate: 61,5 k€ for 30 ATCs + 31 k€ for each extra group of 15 ATCs.

Racks for 30, 45 or 60 ATCs

o Racks for DSS in Experimental Hall

For an array of 30 ATCs 7 racks (2,2 m high) will be necessary for DSS, including LVPS, Autofill, HV and DSS control as well as pre-processing (V2 electronics).

The corresponding power requirement in the experimental hall is estimated to be 19,2 kW.

The numbers of racks (2.2 m high) in the experimental hall increases by 3 for each extra group of 15 ATCs with a full power estimated to be 28,8 / 38,5 kW for an array of 45 / 60 ATCs.

Cost estimate: 0,6 k€/rack resulting in 4,2 k€ for 30 ATCs, and another 1,8 k€ for each extra group of 15 ATCs.

o Racks for Data Flow in the Data Acquisition area

For an array of 30 ATCs 8 racks (2,2 m high) will be necessary for anodes and services servers as well as for the GTS.

Full power in the Data Acquisition area is estimated to be 35 kW.

The numbers of racks needed for an array of 45 / 60 ATCs will increase by 3 for each extra group of 15 ATCs with a full power estimated to be 53 / 70 kW for an array of 45 / 60 ATCs.

Cost estimate: 0,6 k€/rack resulting in 4,8 k€ for 30 ATCs, and another 1,8 k€ for each extra group of 15 ATCs.

Cables and other items for 30 / 45 ATCs

- LVPS cables:

- 45 x 48V cables are available at GANIL, 45 extra cables are needed to reach 90 capsules + another 45 for each extra group of 15 ATCs.

Cost estimate 2.5 k€ to reach 90 capsules + 2,5 k€ for each extra group of 15 ATCs,

- 15 x 6V/12V cable sets (including the 2 cables from LVPS to patch box) are available at GANIL, but only 10 sets are 15m long (necessary for the LNL setup) so that an extra 5 sets must be acquired: 20 extra sets are needed to reach 90 capsules and another 15 sets for each extra group of 15 ATCs.

Cost estimate 17 k€ to reach 90 capsules + 13 k€ for each extra group of 15 ATCs.

- HV cables: 45 are available at GANIL, 45 new cables are needed to reach 90 capsules + another 45 for each extra group of 15 ATCs,

Cost estimate 3 k€ to reach 90 capsules + 3 k€ for each extra group of 15 ATCs.

- Other cables:

Shutdown: 90 cables to reach 90 capsules + 45 for each extra group of 15 ATCs (10€/cable),

Shutdown adapter sets (with new HV system): 90 cables for 90 capsules + 45 for each extra group of 15 ATCs (5€/cable),

PT100 cables (3 or 4 wires) from patch box to Autofill-PLC: 2x30 “cables + new connectors on patch box” to reach 30 ATCs + 2x15 for each extra group of 15 ATCs, (about 50€ for a PT100 20m cable, including connector to patch box + 15€ for the patch box connector),

LN₂ level reading: 15 cables to reach 30 ATCs + another 15 for each extra group of 15 ATCs (about 45€ for a 15m cable with connector on both sides)

Cost estimate: 220€ €/ATC resulting in a total cost of 6,6 k€ to reach 90 capsules + 3,3 € for each extra group of 15 ATCs.

- Profibus cable and terminators. Cost estimate: 3 k€.

- LN₂ metallic hose: to avoid frost and for better thermal efficiency all presently used flexible liquid nitrogen hoses will be substituted by metallic ones. The length has to be optimized on the mechanical drawings (a first estimate could be 3m) to connect the ATC dewar to the LN₂ manifold valves.

Cost estimate: 100€/m resulting in about 300€/hose resulting in 9k€ for 30 ATCs and another 4,5k€ for each extra group of 15 ATCs.

- Bayonets: due to the new metallic hoses to be used, all bayonets, including their thermal shield, need to be renewed: 1 bayonet/ATC is needed.

Cost estimate: 500 €/bayonet resulting in 15 k€ for 30 ATCs + 7,5 k€ to instrument each extra group of 15 ATCs.

- The patch boxes for 21 ATCs have been produced by Irfu and IPHC (Strasbourg).

Another 10 patch boxes are needed for 30 ATCs + 15 patch boxes for each extra group of 15 ATCs.

Cost Estimate cost 6 k€ to reach 30 ATCs + 9 k€ for each extra group of 15 ATCs.

- The 70 LN₂ cards for the full array have already been produced by IKP Cologne.
- MDR cables of 10m are available to complete up to 45 capsules + spares.

Each capsule requires 7 MDR cables and an ATC 21 MDR cables, so that 315 MDR cables are necessary to complete 30 ATCs (90 capsules) + another 315 MDR cables for each extra group of 15 ATCs.

Cost estimate: 150€/MDR cable resulting in 47,3k€ to reach 90 capsules + 47,3k€ for each extra group of 15 ATCs.

Spares for all different cable types are also needed. An extra quantity of ~ 10% should be considered.

- Optical cables:
 - For V0 and V1 electronic channels:

Optical cables are available to complete up to 45 capsules (with 24 V0 type and 21 V1 type electronic channels + V1 type spare).

- The MPO optical fibres for digitizer to pre-processing connexions, from experimental room to Data Acquisition room (60m, max 100m), are provided by the Host Lab.

The FEE group is taking care of the necessary fibre adapters for the new digitizers.

- From pre-processing/GGP to GTS tree (12 m):
100 total optical links are already installed at GANIL: 4 for the 24 channels of V0 electronics and 21 for the 21 channels of V2 electronics.
- LC/LC optical links (1m) from ATCA to GTS:

40 of these links are presently installed at GANIL and cover all necessities for the 24 channels of V0 electronics. V1 and V2 electronics do not need such optical links.

○ For V2 electronic channels:

- The optical fibres (1 cable, including TX and RX, per capsule, 10 Gbps Ethernet, 60m max 100m, cost estimate 90\$/capsule) from pre-processing (in experimental area) to Data Flow (in Data Acquisition room), are provided by the Host Lab.

These optical fibres are not directly compatible with those used for V0 and V1 types electronics but they might be adapted.

- The connexions from pre-processing (in experimental area) to the Global Trigger System tree (or eventually SMART, anyway placed in the Data Acquisition room) will require one 60m long MPO optical cables grouping 6 of these pairs per group of 6 capsules.

Plans are to produce around 60 channels of V2 electronics to substitute part of the ATCA V0 electronics.

Global cost estimate: 8k€ to reach 90 capsules + 6,3 k€ for each extra group of 15 ATCs.

- The Slow Control will require one 1 Gbps Ethernet connection per capsule to reach the Ethernet. The length of the cables will depend on the position of the Ethernet, still to be defined. In case it will be close to the Data Acquisition room, whether the connection will be done with direct 60m copper cables or through Ethernet switches in the experimental room to group several 1 Gbps cables to 10 Gbps optical fibres to reach the Data Acquisition room is still to be defined.

Maximum Cost estimate: 5k€ for 60 capsules to reach 90 capsules + 3,7 k€ for each extra group of 15 ATCs.

EMC

EMC tests and technical improvements will be progressively introduced on the installation under the IJClab, France supervision. Costs are included in the item costs given in the table.

Construction

The LVPS upgrade is designed by Irfu (Saclay) in collaboration with the company Axis that will build the crates and modules. Note that the LVPS upgrade is being done within the Phase 1 of AGATA and it will be used already to instrument the last 5 ATC's of this phase.

The Autofill upgrade will be done by Irfu (Saclay).

The cables will be bought by the collaboration.

Costs & Efforts of Phase 2

The following table summarises the costs and responsibilities for the upgrade to 30, 45 and 60 Clusters.

Items	No. units to reach 30 ATCs (90 capsules)	No. units to be added for each extra group of 15 ATCs for each ATC (45 extra capsules)	Costs/u. (k€)	Costs to reach 30 ATCs (k€)	Costs to be added to reach 45 ATCs (k€)	Costs to be added to reach 60 ATCs (k€)
LVPS	30	15	-	186	72	72
HV	1 Mainframe Full + 12 HV boards	1 Mainframe Base + 6 HV boards	10,8 / 5,8 + 3,95	58,7	29,5	23,7
Autofill + PLC + Profibus	1 system	1/2 system	61,5	61,5	31	31
Racks (2.2 m) Exp. Hall Data Flow. area	7 8	3 3	0,6	4,2 4,8	1,8 1,8	1,8 1,8
Metallic hoses + bayonets	30 30	15 15	300 500	9 15	4,5 7,5	4,5 7,5
LVPS + HV Cables	45 cables 48V 15 sets 6/12V 45 HV	45 cables 48V 15 sets 6/12V 45 HV	-	3,1 * 18,7 * 3,3 *	3,1 * 14,3 * 3,3 *	3,1 * 14,3 * 3,3 *
Profibus Network	1	1	3	3	3	3
Patch Box	10	15	0.6	6,6 *	9.9 *	9.9 *
Other detector cables	-	-	0,22	7,3 *	3,6 *	3,6 *
MDR cables	315	315	0.15	52 *	52 *	52 *
Optical links including GTS and Slow Control	V0/V1: available V2: 60	V2: 90	-	8,8 * 5,5 *	6,7 * 4,1 *	6,7 * 4,1 *
TOTAL				447,5	247,5	241,7

* Numbers include 10% for spares

The LVPS upgrade will be done by Irfu, France. The estimated time needed is:

- The first product requires 4 to 6 months, including tests at Saclay and GANIL. (Note that the first upgraded LVPS is procured within the Phase 1 of AGATA).
- The series production requires 2 to 4 months, depending on the number of crates and modules to be produced.

The Autofill upgrade will be done by Irfu/CEA, France. The estimated time needed is:

- Development of software and networks: 1.5 man-year
- Electrotechnical concept: 3 months
- Production monitoring for wiring cabinet + tests: 2 months

The EMC test and technical improvement will be done under IJClab, France supervision.

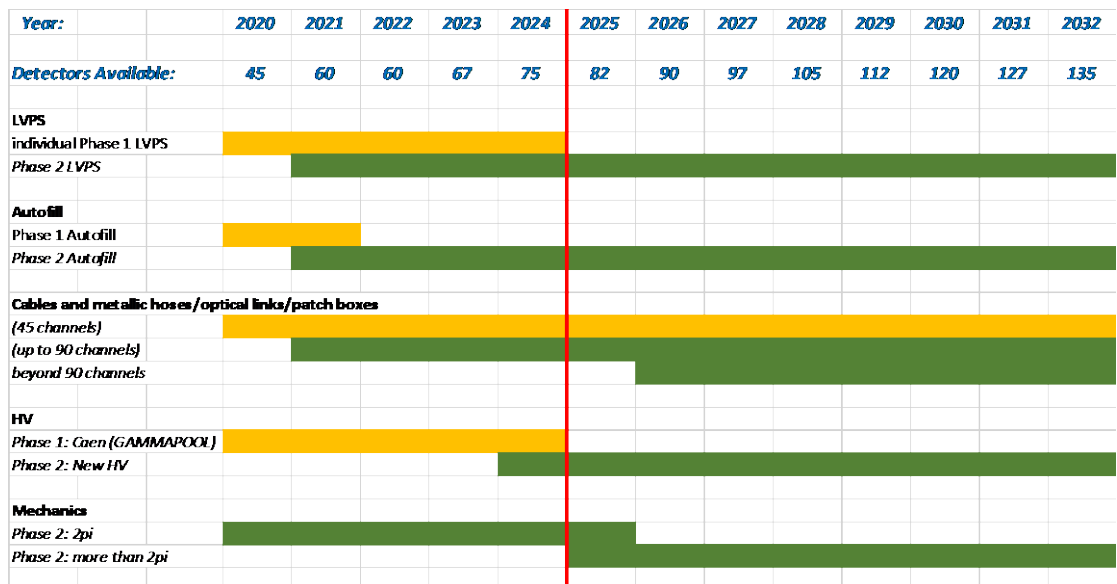

Schedule for the Infrastructure Upgrade in Phase 2
(yellow: use of existing infrastructures, green: use of Phase 2 upgrades)

Maintenance Commitment

Irfu, Saclay is in charge of the maintenance of the LVPS and LN2 autofill control systems with the help of the local team for diagnostic and first maintenance.

Regular maintenance would require about **2k€/y** for replacement of fans, internal dedusting, change capacitors and international transportation.

Mechanical Infrastructure Subsystems

Introduction

This section comprises the description of the mechanical support structure of the AGATA array and the requirements for the installation of the AGATA array in any of the possible host laboratories. This mechanical project foresees the possibility to be used for the full 4π array. It includes:

- The manufacture of the necessary flanges to enlarge the Honeycomb up to the 30, 45 or 60 ATC arrays,
- The main support of the array based of a shaft able to sustain and rotate the 2π AGATA array. It can be doubled for the 3π or 4π array, and
- Mechanical design and manufacture for a new scheme for detector mounting.

Upgrade/Plans for Phase 2

AGATA Main Frame

- *Present main frame (1π)*

The present AGATA main frame installed at GANIL is capable of holding the 15 flanges (1π) of the Modular Detector Mounting structure (honeycomb). This corresponds to 15 ATCs, 45 crystals. It has been designed in such a way that the detectors can be loaded or unloaded at a safe working height. This is done by allowing the structure to rotate so that all detectors can be loaded/unloaded from the horizontal position.

The frame can also translate from the target to an upstream position to allow access to the target area.

- *Future main frame (2π to 4π)*

The future AGATA main frame needs to be able to hold the 2π array, to rotate it $\pm 90^\circ$ for detector loading procedure, to translate it for access to the target area. Moreover, it should easily be enlarged up to the 3π or 4π array and it should optimize the compatibility between the different Host Labs. The mechanical design for the 2π array is being performed by STFC (Daresbury Laboratory, UK), and is under validation by the AGATA mechanical working group as well as the future Host Labs.

The 45 or 60 ATC arrays will need the full 4π structure to be hold. This will require to double the 2π structure.

The present section describes the structure for the 2π array.

The main parts of the 2π array main frame are:

- Enlargement of the honeycomb up to 30 (2π) flanges,
- main shaft and its support,
- base raft,
- linear drive,
- cables support.

The honeycomb needs to be enlarged up to 30 flanges by adding 15 flanges to the present ones. When using AGATA in the target point of a magnetic spectrometer 3 cut flanges need to be used on the horizontal plane to allow for a continuous rotation of the system without clashing with the beam tube. Consequently, the construction of 19 flanges, including 1 spare, is required.

Cost estimate of 1 flange: 0,92 k€
and for 19 flanges: 17,5 k€

This cost is for material only, machining will be provided by INFN Padova and LNL.

The main structure consists of the honeycomb being mounted to a rotating axle shaft. The axle shaft is hold on a support structure and fixed by two bearings. The full system is mounted on slide rails to allow for its translation and open access to the target chamber.

Cost estimates:

- Axle shaft and bearings: 9,8 k€
- Axle support structure: 3,5 k€
- Axle motor drive and gearbox systems: 16,7 k€
- Slide rails for target access: 4,2 k€
- Motor gearbox and controls for slide rail system: 8,4 k€
- Slide support plates and kinematic mounts: 4,2 k€

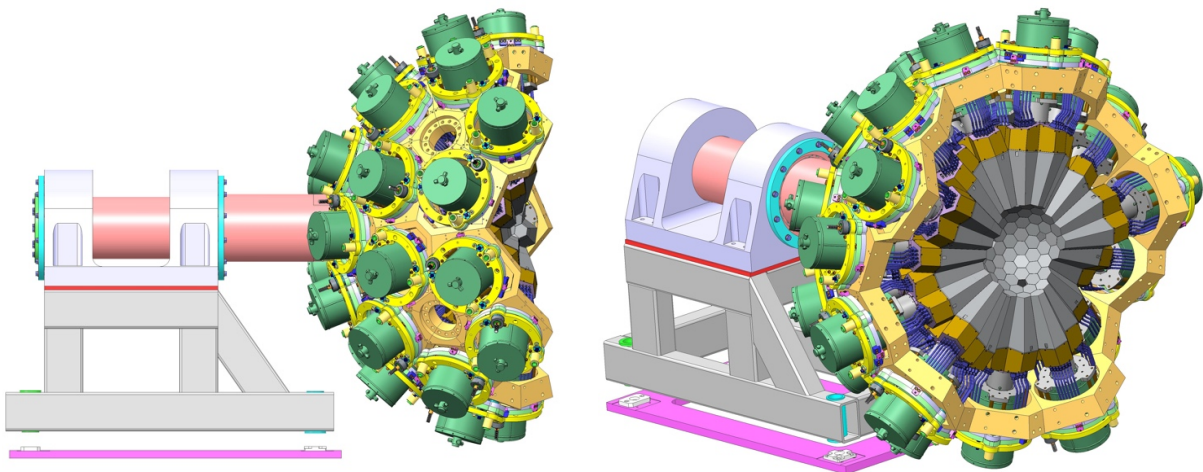

**Two views of the AGATA array (2π) mounted on its rotating axle shaft.
Platforms and lower supports not shown.**

The installation of the AGATA array at FAIR, even in the case of a 2π array (30 ATC), will require the use of 2 axle shafts to allow for the lateral opening of the array, and for the full honeycomb structure to ensure stiffness and stability.

Moreover, due to the position of the pentagon holes in the Honeycomb structure, the whole structure needs to be tilted, about 40° with respect to the perpendicular direction to the beam tube, so that 2 pentagons holes are facing each other making it possible for the beam tube to pass through the full structure.

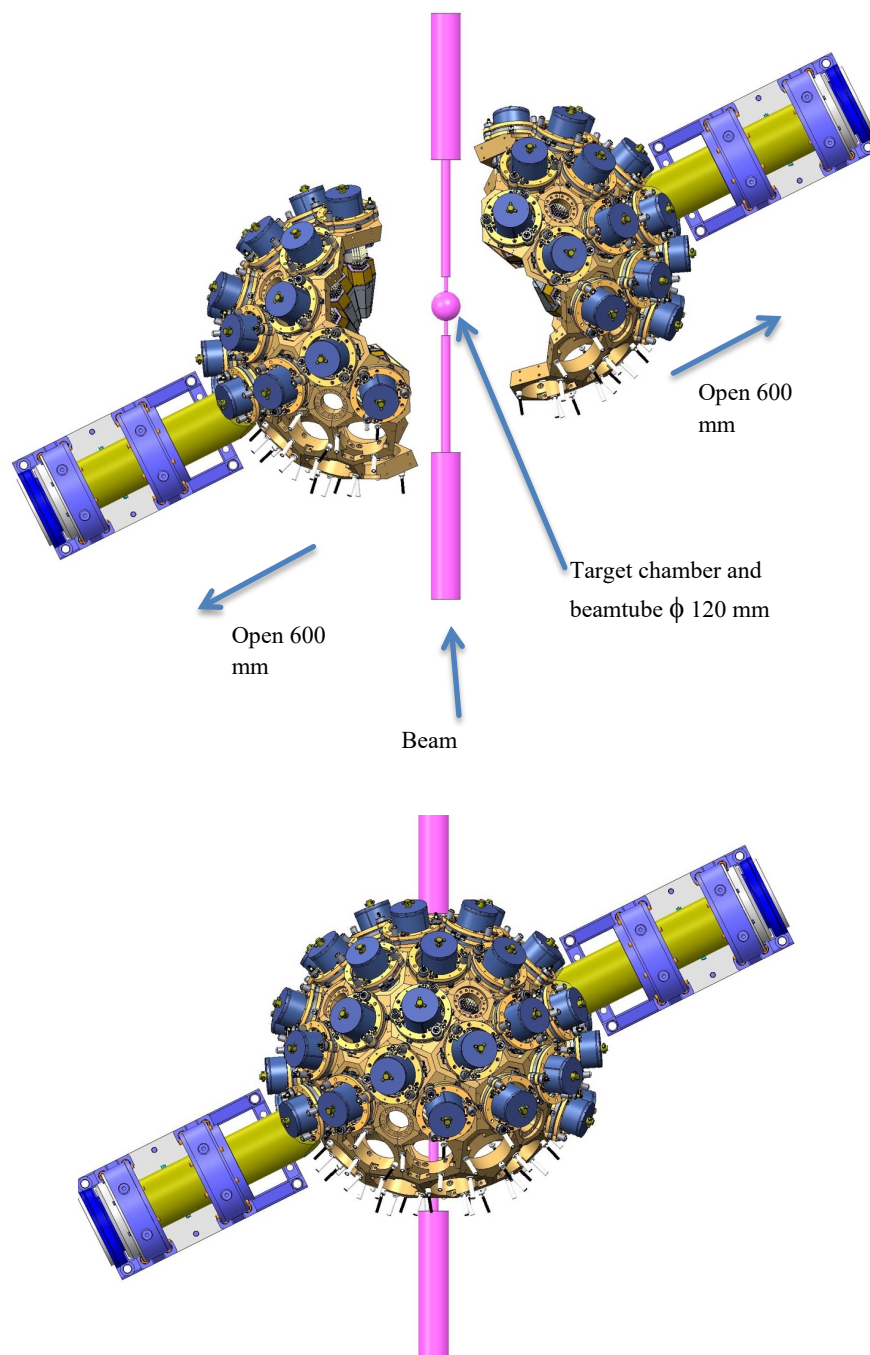

Upper panel: AGATA array installation for the case of 45 ATCs to allow for lateral array aperture as will be used at FAIR LEB cave. Lower panel: same with the AGATA array (3π) closed. Platforms and lower supports not shown.

Surveyor pieces and procedure will be incorporated in the design. Additional materials (laser reflectors) installed in the cave prior to final alignment are of the Host Lab responsibility.

A control system with interlocks and step motor is required to ensure that the transition from rotational to transverse operation is undertaken in a controlled and safe manner.

Consideration also needs to be made for the grounding necessities for such a structure and cabling.

- *New scheme for detector mounting*

The main frame should be capable of allowing the AGATA detectors to be positioned within 0.5mm of each other. At this stage each detector should have its own adjustment system to ensure that detectors will conform to this requirement. A detector trolley and a detector jig are in use on site to adjust the orientation of the detector with the relative detector holding rings before being inserted in the honeycomb. Up to now 20 detector adjustment mechanics (holding ring systems) are available.

There are 9 detector legs and 3 detector leg adapters available for holding the detectors when not mounted on structure.

Provision must be made to allow detectors to be safely and repeatedly installed to their operating position.

A revision of this adjustment system is under study to simplify the procedure including shortening the leadscrew to avoid clashing with the lower support plates. The 15 flanges presently being used will need to be modified accordingly and a new mounting fixture to be built.

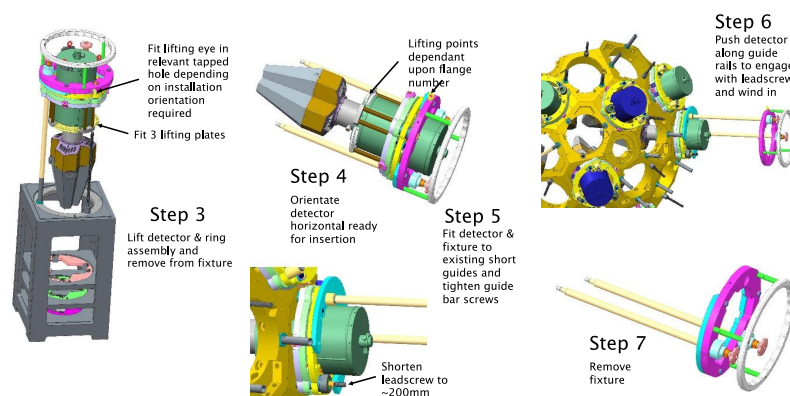

New scheme for detector mounting

The use of an EasyArm crane is planned to allow for precise lifting and safe load/unload of the detector.

Cost estimates:

- adjuster ring assembly, leadscrew and bars etc: 5,0 k€ per ATC, leading to 50,0 k€ for 10 units to reach the 2π array, and another 75k€ for each extra group of 15 units.
- Cost estimate of the new mounting fixture, including a dummy detector: 8,6 k€
- Cost estimate of EasyArm crane and lifting jig: 41,9 k€.

Costs & Efforts

Costs summary for 30 / 45 / 60 ATCs (i.e. 90 / 135 / 180 capsules)

item	Units for 30 ATCs	Extra units for 45 ATCs	Unit price [k€]	Total cost for 30 ATCs [k€]	Extra cost for 30 ATCs at FAIR [k€]	Extra cost for 45 ATCs [k€]	Extra cost for 60 ATCs [k€]
Honeycomb flanges (including 3 cut flanges and 1 spare)	19	30	0,92	17,5	+ 27,6	-	-
Mounting fixture and dummy detector	1	-	8,6	8,6	-	-	-
Adjustment rings	10	15	5,0	50,0	-	+ 75	+75
Axle shaft and bearings	1	1	9,8	9,8	+9,8	-	-
Axle support structure	1	1	3,5	3,5	+ 3,5	-	-
Axle motor drive and gearbox systems	1	1	16,7	16,7	+ 16,7	-	-
Slide rails for target access	1	1	4,2	4,2	+ 4,2	-	-
Motor gearbox and controls for slide rail system	1	1	8,4	8,4	+ 8,4	-	-
Slide support plates and kinematic mounts	1	1	4,2	4,2	+ 4,2	-	-
EasyArm crane and lifting jig	1	-	41,9	41,9	+ 0	+ 0	+0
GRAND TOTAL				164,8	+ 74,4	+ 75	+75

The estimate effort from STFC (Daresbury), for the design, trial assembly in the UK and assistance in installation in Legnaro and the following host site is 63 person-months.

Production and mounting of the flanges as well as of the detectors by INFN-Padova, INFN-LNL is estimated about 12 person-months.

Construction and Commitments

Construction of the flanges will be done by INFN-PD and LNL.

Construction of the axle shaft supports, detector mounting fixture and adjustment rings will be made by external companies.

Installation will be taken care of by Host Lab local team with assistance from INFN-Padova (for the LNL setup) and STFC (Daresbury Laboratory).

STFC (Daresbury) will assure the following of the project and the design adjustments when necessary.

AGATA Mechanical and Detector Infrastructure at the LNL (Host Lab responsibility)

Introduction

As the first future Host Lab will be LNL from mid-2021, this section comprises the definition of the specific requirements to this Host Lab for the mechanical infrastructure related to the installation of the AGATA array in one of the experimental areas of the Host Lab. The corresponding work and procurement are responsibility of the Host Lab. When future Host Labs will be defined this section will be updated.

The physics program planned at LNL/SPES, with stable as well as radioactive beams, requires to have the possibility to couple the AGATA array to the magnetic spectrometer PRISMA as well as to have it in a standalone configuration. For this last configuration the project includes the possibility to shift the target position by about 3.6m off the target point of PRISMA.

Plans for Campaign at LNL (up to 30 ATCs)

- Two possibilities are being prepared for the mechanical design and manufacture of the main support structure for the AGATA array:
 - 2π main support structure facing PRISMA magnetic spectrometer for a 27 ATC array (as 3 ATCs will be removed in order to achieve a continuous angular range moving capability),
 - 2π main support structure facing any other big ancillary detector, like NEDA as an example, for a 30 ATC array,
- Mechanical design and manufacture of the target area (beam line, target chamber and loader),
- Mechanical design and manufacture for services integration.

When coupled to PRISMA the AGATA support system will have to be coupled to the inner rotating PRISMA ring and new outer rotating ring and mounting structure.

In addition to the AGATA detector support, an additional platform needs to be designed to support the digitizers and DSS.

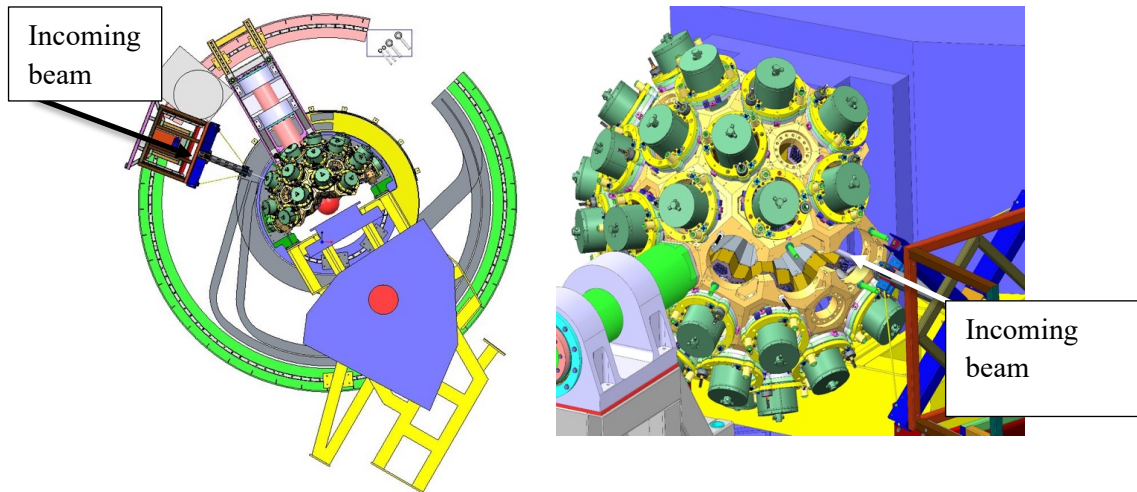

PRISMA and AGATA, left: overview of at 40°, right: 3D view at 70°

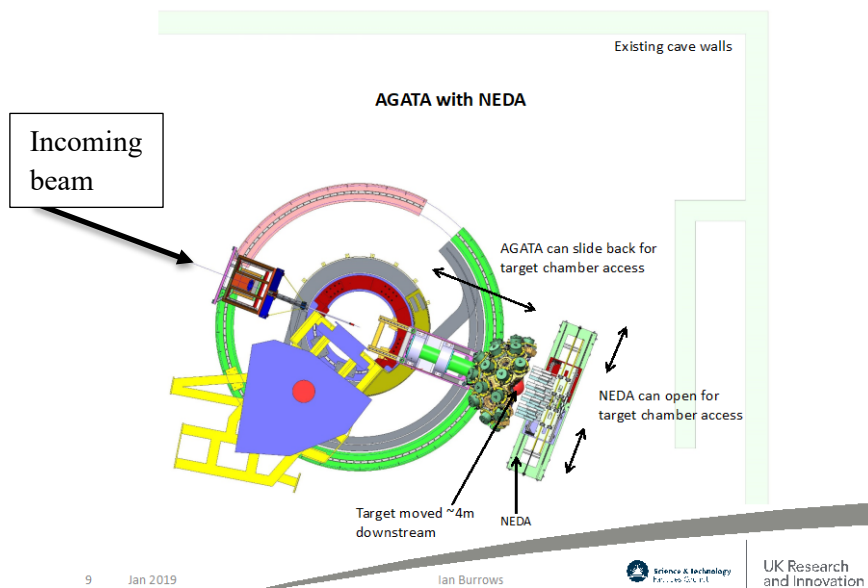

Overview of AGATA displaced by about 3.6 m away from PRISMA target point to allow for coupling with other big ancillaries as for example NEDA

AGATA Services

This section considers the mechanical requirements of cabling and water installation to the required parts of AGATA, the positioning and routing of services from digitizers and LVPS to the detectors and the routing of cooling water to the digitizers.

Cable routing from digitizers to detectors

There is a requirement to have the digitizer positioned within 10 m of the AGATA detectors. The requirements to rotate and translate the detector array imply that cable coilers will be needed to guide all service cables to the digitizers. It is expected that these will be mounted on the additional platform following the different mechanical motions.

Cable routing from Low Voltage Power Supplies to detectors

There is a requirement to have the low voltage power supplies positioned within 15 m of the AGATA detectors. It is expected that they will be mounted on the additional platform following the different mechanical motions.

Sufficient power plant to equip all capsules with the various available digitizers needs to be guaranteed and mounted on an UPS.

During any shutdown, the Host Lab need to guarantee that at least the LN2 automat and control will be powered via a safe system.

Routing of cooling water to digitizers

There is a requirement to have water cooling to the digitizer racks. A cold circuit needs to be prepared and the distribution needs to be mounted on the digitizer platform.

Routing of optical links to digitizers

Optical link for V0 and V1 electronics from the digitizers to the pre-processing electronics will be guided using articulated cables trays.

Costs & efforts for Host Lab

Cost Summary

Item	Price [k€]
PRISMA coupling structure	5,8
PRISMA additional curved support rails and plates	17,3
AGATA support system for use with other big ancillaries (NEDA)	8,4
Additional rail support system for other big ancillaries (NEDA)	9,2
DSS platform	To be defined
Cable routing from digitizers to detectors	To be defined
Cable routing from Low Voltage Power Supplies to detectors	To be defined
Routing of cooling water to digitizers	To be defined

Efforts estimate

The efforts from INFN-Padova and INFN-LNL for the design and installation of: liquid nitrogen distribution, cable management, the additional curved support rail for AGATA and PRISMA, platform for the racks and of the shaft as well as its alignment are estimated in about 40 person-months.

The efforts from INFN-Milano for the design, production and installation of the reaction chamber and accessories are estimated in about 14 person-months.

Performance Monitoring, Simulations and Commissioning for the Phase 2 of AGATA

Simulations

The response of the AGATA crystals has been modelled using the Geant4 simulation toolkit since the very beginning of the project for the overall design of the array and, more particularly, for a complete array of 180 crystals [1].

During the last few years, as the project advanced step by step, crystal by crystal, into its exploitation phase, the simulation work has been focused on the preparation of the experiment proposals and the data analysis of performed experiments [2, 3, 4]. Each time, the simulated response of the array was revisited considering the increasing number of operational crystals. These experiments have been carried out at different host facilities: first at INFN (Legnaro) with 15 crystals, then at GSI (Darmstadt) with up to 24 crystals and finally at GANIL (Caen) with up to 44 crystals. Additionally, these facilities provide different beams in term of energy and optical properties which needs to be included in the simulations together with the different ancillary detectors, mechanical structures, plunger devices and vacuum vessels often used with the AGATA array.

During the next decade, the array is expected to continue to be operated at these 3 facilities. However, with the development of FAIR-HISPEC in Darmstadt, SPIRAL2 in Caen and SPES in Legnaro, the experimental conditions at these facilities will change and will need to be included in the simulation as much as possible. Moreover, interests of using AGATA at HIE-ISOLDE with MiniBall and also at Jyväskylä have been recently expressed and are being explored using basic preliminary simulations. Further simulation work with more realistic geometries, new event generators and expected additional ancillary devices is likely to be needed for the array to operate under the experimental conditions offered at these new host facilities.

As the number of working crystals increases progressively between the experiment campaigns, basic simulations of photo-peak energy efficiency and peak-to-total ratio curves are usually performed to provide users with some first estimation. These properties of the array are often requested by users for both a nominal and a compact target-detector distance. When the success of an experiment relies on high detection efficiency, the compact configuration is the preferred option to compensate with the limited number of existing crystals. Depending on the reactions of interest, the array's properties may also need to be simulated for both low or/and high γ -ray multiplicities.

Wherever the AGATA array will be used during the period 2021-2030, the demand for a similar simulation work is expected to continue while the number of existing crystals increases.

With real data from well-known sources or beam reactions, the validation of the simulations is possible. One of the remaining questions regarding the performance of the array is why the simulations always overestimate the measured absolute efficiencies. Could this be due to an underestimation of γ -ray absorption by considering too simple geometries or an effective crystal dimension smaller than expected, or a more fundamental issue in the charge transport model in the detector?

Answers to this question can be provided by performing more realistic simulations.

A lot of effort has been put to implement more realistic geometries of ancillary detectors, reaction chamber, plunger and mechanical structure in the simulation. CAD drawing STEP format files converted into GDML can now be incorporated into the AGATA simulation code to achieve this. Indeed, this has allowed to reduce the gap between measured and simulated efficiency but not completely remove it.

The characterization of each crystal also provides important information and, in particular, more precise information about the crystal relative efficiency and a gross value of the thickness of passive Ge area observed essentially around the coaxial contact and at the back of the detector will be very useful. Here also, the measured relative efficiency is usually a few % lower than the simulated one. With a more accurate location and measurement of the crystal passive area it would be possible to adapt the geometry of each crystal in the simulation to better match the measured efficiency. Since this efficiency is also likely to evolve in time, for instance after each re-processing of a crystal, the effective size of the Ge crystal will need to be updated accordingly in the simulation.

Additional work is also foreseen to develop and complete some event generators. This includes generators for polarization measurements and generators with simplified and better background estimate.

The characterization of the sensitivity of the AGATA array as a polarimeter could lead to interesting new physics opportunities. With the development of event generator for polarization measurements, the simulations would provide crucial preliminary information in that physics research arena.

Attempts to include background measured at some facilities (ex: GSI, GANIL) in the simulation code have already been successful [4, 5]. However, the procedure either relies on previously measured background or a set of different and independent physics background models. In the first case, the background could be quite different from one reaction to another and, if a specific reaction has not been studied before, the simulation prediction then remains somewhat questionable. In the latter case, the procedure is currently tedious as only the outputs of the different models are combined together and there is no tool in place to provide simulated time-stamped background data. So, there is still scope for further development in this area in order to provide more accurate predictions in feasibility studies of future experiments.

Another task that is also important is the maintenance of simulation code, its version control and its dissemination. The AGATA Simulation code is continuously kept up to date with the latest version of GEANT4, while also maintaining compatibility with less recent versions. Currently the code is compatible with GEANT4.10.03 and older version down to GEANT4.7. The version control is managed using Subversion and, for the 2021 to 2030 period, as more communities and applications are using the GIT version control system it is likely that a migration to GIT will happen. Support and training courses will continue to be offered and an update of the Users' guide documentation will also benefit existing and new users.

The development of the code will continue by coupling AGATA with ROOT. The following two options will be considered and at least one will be implemented:

- migrates the AGATA code, including all its event generators and ancillary detectors into an existing simulation and data analysis framework such as ENSARROOT, NPTOOL, STOGS,
- Develop the AGATA code from a pure geant4 simulation code to a GEANT4+ROOT code and avoid the current 2-step process of producing an ASCII output file then transform it into a ROOT file. External algorithms based on ROOT to simulate time-stamped AGATA data have already been developed to produce AGATA Data Format ADF files. Additional work will be carried out to integrate this algorithm into the AGATA code. (Similar capabilities exist also within the STOGS framework and could be re-used for AGATA).

Commitment

The Simulation team is committed to maintain the code's compatibility with the latest GEANT4 releases plus other external analysis tools that advanced simulations require (ex: ROOT). The code will continue to be accessible freely online, via a commonly used version control tool, and the team will continue to provide support for its installation and utilisation.

Commissioning and Performance

In order to ensure that the energy resolution, detection efficiency and peak-to-total ratio expected after PSA and tracking are indeed achieved, dedicated in-beam runs with AGATA are needed. This is particularly important at beam facilities where AGATA has not yet been used and includes the new European beam facilities SPES, SPIRAL2 and FAIR, HIE-ISOLDE as well as at Jyväskylä.

Furthermore, the host laboratories for AGATA have unique complementary devices. In many cases, a test with sources cannot provide a complete evaluation of the setup. Hence, a thorough test using typical reactions has to be performed for validating the functionality of the coupling and to ensure that all impacting effects on AGATA's performance is understood.

As mentioned in the previous section, these measurements with either radioactive sources or well-known in-beam reactions are also used to validate MC-simulation codes and tools, which in turn can be applied more reliably for preparing experiments proposals.

Calibrated radioactive source runs should always be carried out at least prior to a new campaign and consistency of the results should be compared with both simulations and previous measurements obtained at the same or other facilities. Monitoring of performance in the long term is important and it will be crucial to quantify the radiation damage to each of the crystals. It is fundamental to monitor the resolutions and to track the history of each crystals across physics campaign and annealing cycle. Annealing cycle has been shown in the past to have a probability of impacting the functionality of the crystals, it will be interesting to observe and track in the long term to what extent the resolution is recovered and if there could be an effect on the efficiency of each crystal.

During the period 2021-2030 the angular coverage of AGATA will not only be large but will also have a high granularity. In order to profit from this and extract useful physical quantities from angular distributions and correlations (i.e. the multipolarity of emitted γ -rays, mixing ratio, parity) or to perform measurements depending on the perturbation of the angular distribution or correlation, e.g. g-factor measurements, a deepened understanding of the performance of AGATA will be achieved. The main challenge comes from the necessity to normalize the number of counts in a given part of AGATA so that it can be compared to the expected flux of γ rays into the corresponding fraction of solid angle. In a classical array using Compton suppressed HPGe detectors and a common dead-time data acquisition this can be done by efficiency calibration of the individual detectors in the array. However, in AGATA where the notion of detectors is replaced by the first (and second) interaction position of the tracked γ -ray the efficiency calibration is no longer simply detector dependent. An added complication comes from the fact that a given capsule electronics might be busy in a previous event, producing an effective dead time. The use of a Data Flow without common dead time mixing a detector specific part in the problem. One has to note that in order to correctly assign γ -ray intensities emitted from aligned nuclei one has to be able to correctly measure angular distributions and even possible correlations.

Commitment

The performance team is willing to assure that the performance of the different AGATA configurations during the period 2021-2030 will be characterized and evaluated via comparisons to both simulations and known results. A large part of the activity within the performance team is performed within the IN2P3 institute of CNRS, France and this activity is foreseen to continue to be a priority.

AGATA will be installed in new host Laboratories, such as CERN HIE-ISOLDE, HISPEC-FAIR and JYFL. The AGATA Commissioning team will ensure a close

collaboration with the host in finding a suitable commissioning plan of the setup. The radioactive beams delivered by HIE-ISOLDE accelerator will be commissioned with an experiment previously done with MINIBALL. The AGATA-PRESPEC campaign used a primary beam for ensuring the good operation of AGATA. The same is foreseen for the commissioning at HISPEC-FAIR.

The set-up in laboratories previously hosting AGATA, will use updated and new complementary detectors. The correct coupling and operation need to be verified. The new setups have to be checked with suitable radioactive sources and commissioning experiments need to be designed together with experts in the host laboratories. For each installation of AGATA, a new team for the commissioning will be formed under the lead of AGATA Commission team located at the TU Darmstadt, Germany. The available manpower and the experience with AGATA in different installations, will ensure the analysis and the verification of the installation. Together with the performance team, the verification of the expected efficiencies will be performed.

Performance Monitoring, Simulations and Commissioning References

- [1] E. Farnea et al., Nucl. Instr. and Meth. A 621, 331 (2010)
- [2] E. Clement et al., Nucl. Instr. and Meth. A 855 (2017) 1-12
- [3] N. Lalovic Nucl. Instr. and Meth. A 806 (2016) 258-266
- [4] J. Ljungvall, 17th AGATA Week, “*Simulations for lifetime measurements*”, 2016, Orsay
- [5] D. Bloor, 12th AGATA Week,” *Development of a simulation package for fragmentation and Coulex reactions at GSP*”, Darmstadt, June 2012.

Complementary Instrumentation for AGATA Phase 2

Introduction

For many experiments the AGATA array has to be coupled with various ancillary detectors to enhance its selective power and the performance of the complete setup. For AGATA Phase 2 the following ancillaries may be considered: PRISMA, VAMOS, Super-FRS, NEDA, Diamant, EUCLIDES, SPIDER, MUGAST/GRIT, DSSD, HECTOR+, PARIS, FATIMA, LYCCA ...

This section is concentrated on all aspects of the integration of the various ancillary detectors, in particular for i) Front End Electronics and Data Flow, ii) Simulations and Mechanical compatibility, iii) commissioning of the full setup and, as examples, iv) a rapid description of the integration of NEDA and DIAMANT as was done during the 2018 campaign in GANIL, v) the GRIT integration in its MUGAST version in the AGATA setup at GANIL and finally vi) notes for the GSI/FAIR future setup integration.

The activities foreseen for the integration of the various ancillary detectors in the coming Phase 2 of AGATA are regarding both FEE developments and simulations to determine best efficiency with mechanical compatibility in the various Host Labs.

Front End Electronics and Data Flow integration

Present situation

The Complementary detectors team developed in the past a general purpose VME interface (AGAVA) for the AGATA GTS. Currently the collaboration has 10 AGAVA VME cards that can be used for ancillary detectors with analogue Front End Electronics (FEE).

Up to now, various ancillaries have been used in the AGATA setup with such an AGAVA interface: VAMOS/PRISMA, PARIS, FATIMA, Silicon arrays like Spider, DSSSD detectors. During the 2019-2020 AGATA-VAMOS-MUGAST campaign, also the VAMOS and MUGAST setups have been coupled to the AGATA GTS Tree using an AGAVA board.

AGAVA VME cards cannot be produced anymore in its present version due to the obsolescence of some of its components. Moreover, many ancillary detectors are now using digital FEE to optimize count rate capability, therefore, Front-End Electronics (FEE) with digitalization capabilities on board (NUMEXO2) compatible with the new AGATA GTS has been developed and used in the AGATA+NEDA+DIAMANT campaign in GANIL in 2018.

The early AGATA trigger processor had a maximum number of 40 nodes available and this represented a limit with the increasing number of crystals and/or when two or more detectors with a large number of channels were coupled to AGATA. An EXOGAM2 trigger processor, developed by GANIL, can cope with up to 255 nodes and have been used successfully in the 2018 AGATA+NEDA+DIAMANT 2018 campaign.

The coupling of both the synchronization and triggering systems for the complementary detectors using conventional (VME or else) electronics with the AGATA setup, has been implemented by both the AGATA Electronics Working Group and the GANIL GAP experts and the different ancillary collaborations.

Upgrade/Plans for Phase 2

Several systems involved in the ancillary integration will need to be upgraded for Phase 2. In particular the GTS system is limited in the number of channels and is getting old and some components are obsolete.

For the LNL campaign, the integration of ancillaries will be based on already used techniques adapted to the local Data Acquisition framework.

For the GSI/FAIR campaign, the integration of the SuperFRS and LYCCA detectors will need to be duly prepared.

GTS upgrade

As mentioned in the section devoted to the Front End and pre-processing Electronics Subsystem, more likely the future Trigger and Synchronization system will be based in the SMART hardware and firmware under development at GANIL. The SMART system includes the Trigger Processor in the HUB board, that will be built under the micro-TCA standard. SMART has a broad compatibility with the NUMEXO2 hardware as well as the CENTRUM synchronization system.

In the hypothesis of a new SMART Global Trigger System (GTS) it might be necessary to develop an interface for complementary instrumentation not using the SMART GTS. A general-purpose board, as AGAVA for the GTS system, should be developed.

Integration of ancillaries in LNL setup

Electronics integration upgrade

The integration of the ancillaries at LNL will strongly benefits from the development made for the local γ -ray spectrometer GALILEO. As the GALILEO array uses a similar FEE than AGATA, GGP+DIGIOPT12 synchronized using the GTS system, all the GALILEO ancillaries are already GTS compliant. This covers the silicon detectors for charged particles (EUCLIDES, GALTRACE), for heavy ions (SPIDER), and the large volume LaBr₃ for high energy spectroscopy. Up to 10 GGP-DIGIOPT12 systems are available for those ancillaries covering up to 360 channels.

Additional ancillaries' integration, such as the PRISMA large acceptance spectrometer is still under study. The readout chain of the PRISMA spectrometer is indeed a limiting factor for the stable beam campaigns and suffers from large deadtime for in-beam data taking. An upgrade of this readout is currently under discussion and new solutions are investigated. The use of commercial CAEN digitizers could benefit from the simplification coming with the SMART synchronization system which includes a White Rabbit interface. Clock compatibility between the GTS and the CAEN digitizers has been tested with a dedicated PLL firmware developed by CAEN. This first step is important for the coupling of commercial solution with the AGATA hardware. However, as long as the timestamp, in terms of absolute number, is not shared, even merging remains complicated.

Other ancillary detectors, such as NEDA or GRIT already used with AGATA in GANIL will be coupled to AGATA in LNL in a similar way.

Data Flow integration upgrade

Concerning the data acquisition for the next LNL phase the ancillary detectors will be acquired using the host laboratory data acquisition framework, namely XDAQ. As in GANIL NARVAL acquisition chain, actors will be set to ensure the data transmission between the two. Choice was already made to transmit only ADF format data frames to facilitate the merging with the AGATA data and simplify the online and near-line analysis.

The actor in charge of the communication between XDAQ and DCOD is currently under development between the LNL local team and the AGATA Data Flow team. The local team is taking the responsibility to produce a Run Control graphical interface for the users which will be able to communicate with the two acquisitions in order to synchronize the start/stop operations.

Data Flow monitoring will be implemented into a GRAFANA solution using the SOAP/REST capabilities of the DCOD and XDAQ environment. This platform will allow to keep trace of the performances of the readout during the experiment. The GRAFANA server will also include a monitoring of the electronic rates, but also status (temperature, backpressure, ...). This part is already under test using the GGP of GALILEO.

Simulations and Mechanical compatibility of AGATA with the Complementary Instrumentation

The simulation of the performance of AGATA and of the complementary instrumentation in realistic conditions is a priority for the ancillary detector collaborations. It is their duty to perform the simulations for the AGATA + ancillary detector setup in the various Host Lab with the help from the Simulation and

Complementary Instrumentation working teams. The collaboration proposing the coupling of a complementary instrumentation with AGATA will take care of the mechanical compatibility between the two setups, working in collaboration with the AGATA Complementary Instrumentation Team and the host laboratories.

Commissioning of the AGATA + Complementary Instrumentation setup

The Commissioning of the integrated complementary instrumentation in the AGATA setup, when necessary, will be organised by the ancillary collaboration with the help of the Commissioning working team. Either source or beamtime will have to be considered if necessary.

Example of the NEDA/Neutron Wall + DIAMANT integration in the AGATA setup at GANIL

Mechanics integration

In 2018, after a first successful commissioning with the EXOGAM2 γ -ray array, NEDA and Neutron Wall have been coupled to AGATA. The newly built NEDA detectors were placed at forward angles while the Neutron Wall detectors were arranged in a ring-like configuration close to 90 degrees as shown on the figure below. Due to the limited place in the G1 experimental hall, the choice was made to have a compact mechanics opening perpendicular to the beam line in order to facilitate the mounting of the 54 NEDA detectors. The 42 Neutron Wall detectors distributed in 12 hexagonal triples were mounted in-situ. In total, the newly designed mechanics was able to host up to 96 liquid scintillators.

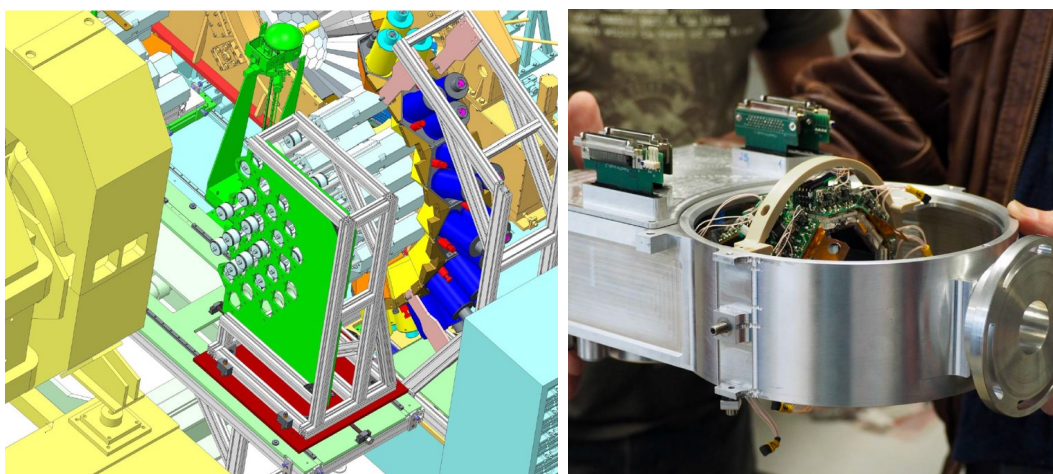

Left: Mechanical design of NEDA and Neutron Wall fully integrated with the AGATA array Right: DIAMANT array placed in its dedicated reaction chamber

Front-End Electronics

The NEDA/DIAMANT Front-End Electronics (FEE) is fully-digital and based on the NUMEXO2 boards. Depending on the applications, the digitizers can be read either via ethernet (DIAMANT) or optical fiber (NEDA). For NEDA, each of the 6 NUMEXO2 board is connected via point-to-point MPO optical fiber to 6 dedicated servers allowing to readout the detector traces for further processing. Neutron- γ discrimination and charge particle identification were implemented by the respective collaborations onto the digitizers' firmware. The NUMEXO2 boards present the advantage of being fully integrated in the Global Trigger and Synchronization (GTS) system which simplify the coupling with the AGATA electronic. Slow-control and GTS settings are controlled for all NUMEXO2 boards via ethernet.

The NEDA first-level trigger enables the neutron- γ discrimination block used to generate the Trigger Request to the GTS system. The block is composed of two algorithms based on PSA and time of flight technique that can be combined to generate the logic signal used by the GTS validation/rejection cycle. The conditions on the neutron- γ discrimination block can be adjusted to ensure a maximum validation rate in the capability of the online PSA.

To simplify the coupling of the NEDA/DIAMANT arrays with AGATA, a local GTS sub-tree was implemented in the G1 cave. This consisted in two NIM GTS carrier with 7 GTS mezzanines coupled with a single long optical fiber to the AGATA GTS tree located in the computing farm room.

The data frames are compliant with the MFM GANIL data format specification. NEDA/DIAMANT data are sent to the NEDA Data Acquisition servers via MPO optical fibers.

Slow control and GTS services can be performed remotely via ethernet.

Data Acquisition integration

The data acquisition was based on the GANIL NARVAL system. Dedicated actors were developed to read, filter and time order the data.

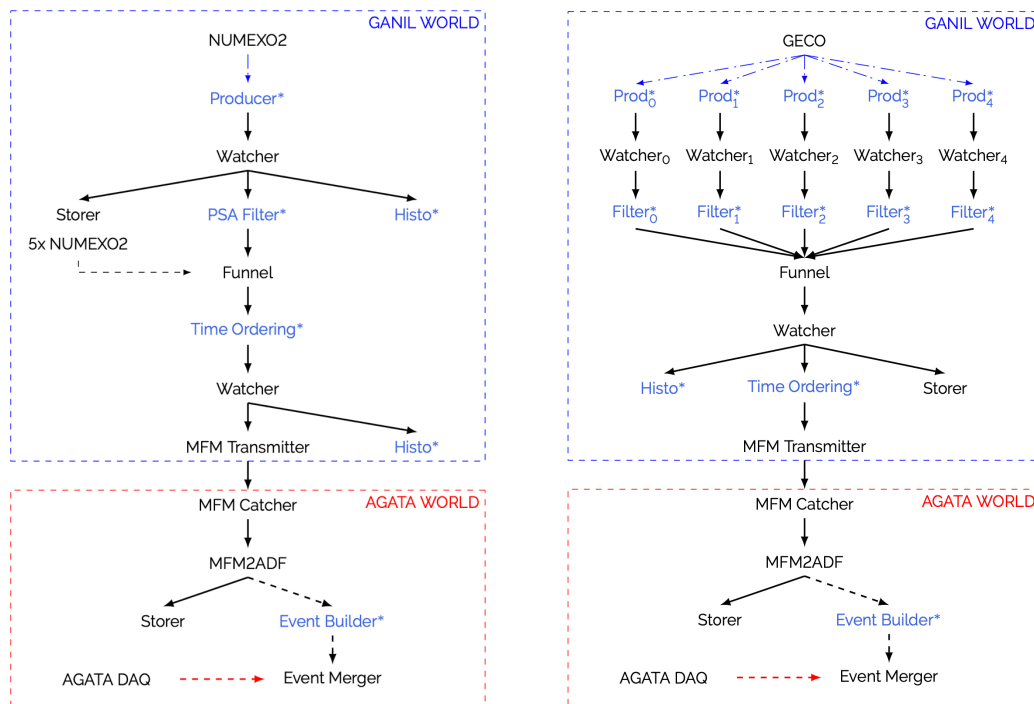

Left: NEDA/Neutron WALL, Right: DIAMANT, scheme of the Data Acquisition..

The readout of all the boards is concentrated to an ethernet switch and sent to one dedicated server taking care of all the DIAMANT data processing before being sent to the AGATA world.

The acquisition systems are shared between two networks: the GANIL and the AGATA network. During the online data taking, data were written after the MFM2ADF for both NEDA and DIAMANT and merged with the AGATA one in the near-line analysis.

Example of the GRIT integration in its MUGAST version in the AGATA setup at GANIL

Mechanics integration

GRIT has been used in its first version, called MUGAST, in the 2019 and 2020 campaigns at GANIL. The array is composed of 8 Double Side Stripped Silicon Detectors and 4 MUST2 detectors covering altogether an angular range of 7.5° - 90° and 104° - 169° .

The mechanics has been developed with the possibility of lateral translation of the full detector system to allow for silicon detector handling and maintenance. Moreover, it includes both the silicon detector pre-amplifiers and their cooling system.

The vacuum chamber has been designed to allow for the integration of a ^3He cryogenic target, as visible on the figure.

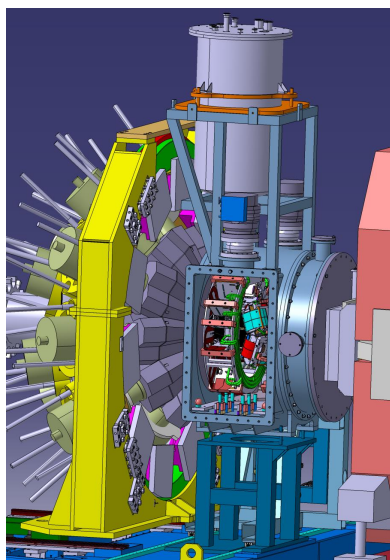

MUGAST integration in the AGATA VAMOS setup at GANIL.
The grey dewar of the ^3He cryogenic target is visible at the top centre of the figure

Front-End Electronics

The analog electronics of the MUST2 detectors was coupled to the AGATA electronics through the VME AGAVA board.

Data Acquisition integration

The acquisition is fully integrated in the GANIL NARVAL environment and the data are sent to the AGATA DCOD environment via MFM transmitter and catcher like for VAMOS coupling and NEDA/DIAMANT one.

Beam selection detectors and ancillary integration in the AGATA setup at GSI/FAIR

Integration of the GSI/FAIR ancillary from the point of view of the data acquisition will be performed in a similar manner than for the GANIL and LNL phase. Based on the experience of GANIL/NARVAL, a DCOD API C/C++ is under development by

the AGATA data acquisition team for the phases. This data transfer API between the DCOD and host laboratory will be tested before the LNL phase and improved during the coming campaign. This will allow a simpler coupling of the ancillary devices data acquisition with the AGATA DCOD environment. Or from the point of view of the local host laboratory, a simpler integration of the AGATA DCOD into the local data acquisition system.

Following the NUSTAR data acquisition technical report, the synchronization of the electronic modules and time stamping of the events of the GSI/FAIR detectors will be done using a White Rabbit (WR) network. This will allow a sub-nanosecond synchronization of the ancillary devices between them. Contrary to the GTS system, the WR solution does not come with trigger functionalities (trigger request, validation, common dead time, ...). Thus, although the SMART clock and trigger system might include a WR interface, the development of a new AGAVA board allowing the inclusion of the ancillary devices such as SuperFRS and LYCCA in the AGATA hardware trigger decision is of key importance for the success of the future campaigns. Definition of the requirement for the new board which will be based on the System on Modules (SoM) technology adopted for the Phase II of the AGATA electronic is under progress.

The NUSTAR Data Acquisition (NDAQ), contrary to AGATA acquisition, is built as a triggered system, as the pertinent information from the SuperFRS comes from the coincidence between several detection system. Due to the dimensions of the separator, latency of 5 to 10 μ s are expected between the signals of the first focal plane of SuperFRS and the experimental caves, thus including AGATA. To deal with this large latency, it is foreseen that the electronic of the detector of the separator will run in free running. The events will be store locally on the front-end buffers waiting of a validation signal.

For the coupling with VAMOS (GANIL) and PRISMA (LNL), an AGATA fast trigger (γ -OR) is generated with standard Low Threshold Discriminator (LTD) using the analog inspection of the digitizers. The same technique could be applied for the SuperFRS, with the difference that the LTD modules could be integrated into the NDAQ environment. This would need the addition of the GSI/FAIR NDAQ front-end into the γ -OR rack.

Part of the complementary instrumentations, e.g. LYCCA, was already coupled to the AGATA array during the first GSI PRE-SPEC campaign (2012-2014). Details about the electronic and data acquisition coupling can be found in the publication of D. Ralet et al. (NIM A 786 (2015) 32).

Costs & Efforts

The costs and efforts for the integration of any ancillary detector is the responsibility of the specific collaboration proposing that given ancillary detector. The local team as

well as all the AGATA working teams involved (electronics, Data Flow, mechanics, simulations and commissioning) will help preparing AGATA for the integration. It is then fundamental that they are informed in due time of any relevant technical aspect so that eventual preparation of the AGATA setup can be done when necessary.

Commitment

The ancillary detector collaboration commits to prepare the ancillary detector in due time for eventual tests (mechanical, electronics, Data Flow) that should be done in advance on the AGATA setup, collaborating with the local project manager of AGATA to optimize the calendar of the activities on the setup.

The ancillary integration team commits to participate to the development of the new AGAVA board. Later on, the necessary boards will have to be provided by the respective Host Labs.

In particular it is the responsibility of the ancillary detector collaborations to contact the AGATA Data Flow team as well as the Host Lab local Data Flow team well in advance so that these teams can prepare their part for the integration of the ancillary instrumentation in the full AGATA Data Flow.

Commissioning tests will have to be discussed with the AGATA commissioning team and local AGATA project manager.

The success of an experiment including a given ancillary detector in the AGATA setup is a success for the relative collaboration as well as for the AGATA collaboration. A failure is a failure for both.

Annex I: AGATA Phase 2 summary tables for the tasks, effort and Institutions involved in the 10y period

Summary of the Tasks and Institutions involved

AGATA Subsystem / Activity	Institute	AGATA Subsystem / Activity	Institute
Detector Module		Electronics	
Taking in operation new ATCs	IKP Uni. Cologne Uni. Liverpool Irfu/CEA Saclay IPHC Strasbourg INFN-LNL Uni. Padova	DIGIOPT12 Board Update	INFN-Milano Uni. Milano
Maintenance of Ge-Detectors and ATCs		R&D STARE Board & Firmware	IJCLAB Orsay
Maintenance at the host facility		R&D IDM/PACE Board and firmware Mechanics and PSU	TeDRA Uni. Valencia IFIC-CSIC
Development cryostat		R&D Pre-Processing & Inspection Firmware	IPHC- Strasbourg
Development Ge Detectors		R&D Firmware, Monitoring & Visualization	STFC - Daresbury
PSA & Characterization		Data Flow software development, Control software development	IJCLAB Orsay IPHC- Strasbourg
Characterization Data Analysis for Improvements to the PSA basis	STFC-Daresbury Uni. Liverpool IPHC-Strasbourg IJCLAB Orsay GSI Darmstadt IKP Cologne Uni. Salamanca	R&D SMART (shared)	GANIL Caen
Technical Support for the Improvements to the PSA basis		System Integration and Installation	TeDRA Uni. Valencia IFIC-CSIC IJCLAB Orsay IPHC- Strasbourg STFC - Daresbury
Continuous characterisation campaign for new detectors		DIGIOPT12 Board Maintenance	INFN-Milano Uni. Milano
Technical Support for the continuous characterisation campaign for new detectors		STARE Board Maintenance	IJCLAB Orsay
Performance optimisation of the PSA algorithms		IDM/PACE Board Maintenance	TeDRA Uni. Valencia IFIC-CSIC
New optimised multiple interaction PSA algorithm	Uni. Liverpool Uni. York GANIL-Caen IJCLAB-Orsay IRFU-Saclay IPHC-Strasbourg GSI-Darmstadt IKP Uni. Cologne Uni. Salamanca TU-Darmstadt	PSU Board Maintenance	TeDRA Uni. Valencia IFIC-CSIC
The investigation of alternative PSA algorithms based on Machine Learning approaches		Mechanics Production and Maintenance	IFIC-CSIC, TeDRA Uni. Valencia
Experimental validation of a novel PSA self- calibration method		Firmware Installation, Updates and Maintenance	IPHC- Strasbourg TeDRA Uni. Valencia IFIC-CSIC IJCLAB Orsay STFC - Daresbury
		Monitoring, GEC, Data Flow Software, Installation, Updates and Maintenance	IJCLAB Orsay IPHC- Strasbourg STFC - Daresbury
Data Flow, Data Analysis and Tracking			
Data Flow Developments	IJCLAB Orsay		
Data Flow Maintenance	IJCLAB Orsay		
Network System Administration	IJCLAB Orsay		
Tracking Upgrade Developments	IJCLAB Orsay TU-Darmstadt		
Tracking Maintenance	IJCLAB Orsay		
Data analysis, re-processing & storage Developments	IP2I Lyon IJCLAB Orsay		
Data analysis, re-processing & storage Maintenance	IP2I Lyon IJCLAB Orsay		

AGATA Subsystem / Activity	Institute
Detector Infrastructure Subsystems	
LVPS Upgrade	Irfu/CEA Saclay
LVPS Installation and Maintenance	Irfu/CEA Saclay
Autofill Upgrade Development of Software and Networks	Irfu/CEA Saclay
Autofill Upgrade Electrotechnical Concept	Irfu/CEA Saclay
Autofill Upgrade Production & Test	Irfu/CEA Saclay
Autofill Maintenance	Irfu/CEA Saclay
HV Definition & Test	INFN-Padova
Electromagnetic Compatibility Measurements	IJCLAB Orsay
Construction Data Base Support	IPZ Lyon
Mechanical Infrastructure Subsystems	
Design, Construction, Test and Installation of the AGATA Mechanics	STFC-Daresbury
Production of the AGATA Flanges	INFN-Padova INFN-LNL
Simulations, Performance and Commissioning	
Maintenance, Upgrade and Developments of the AGATA Simulation Code	STFC-Daresbury
Coordination and Realization of Performance Evaluations	IJCLAB Orsay
Coordination and Realization of Commissioning Experimental Activity	TU-Darmstadt
Complementary Instrumentation	
Mechanical, Electronics and Data Flow Compatibility	INFN-LNL

Annex II: AGATA Phase 2 summary tables for the upgrade of AGATA to 135 detectors (3 π)

This annex includes the investment costs tables, the resulting ATC average cost and the Operational and Maintenance Costs for an AGATA array of 135 Encapsulated Detectors (3 π).

All prices are given VAT excluded.

The investment costs are summarized in the following paragraphs and tables:

The total costs to complete and instrument 3 π of AGATA, evaluated with the known prices for 2019-2020 and our best estimate for increasing price index of 1.5%/year, would be **25554,8 k€**. These will be the funds needed for a procurement plan without discount, as was in fact the case for Phase 1.

The total cost to complete and instrument 3 π version of AGATA, evaluated with our best estimate for increasing price index (1.5%/year) and considering the cost reduction offered by, Mirion Technologies for the simultaneous purchasing of 7 or 8 encapsulated detectors, and CTT for ordering 3 or 2 triple cryostats per year, is **21894,7 k€**. The attached table gives the **Expected Costs in k€ per year, purchasing 7 or 8 detectors/year**.

In their quotation, Mirion Technologies, included a maximum increase of the costs of 2.5% per year. With this condition, a maximum cost of **22441,3 k€** for the completion of 3 π of AGATA, is expected.

Costs in k€ per period of 5 years:

Expected Cost purchasing 7 to 8 detectors/year (VAT Excluded)

Item	2021-2025 39/11	2026-2030 39/15	Total
Detector	6768,7	7459,9	14228,6
Cryostat	1266,6	1824,8	3091,4
Electronics	400,1	1032,1	1432,2
Electronics Upgrade	779,5	0,0	779,5
GTS/SMART	104,6	0,0	104,6
PSA & Data Flow	494,8	421,0	915,8
Storage	117,6	124,9	242,5
Analysis	10,5	22,9	33,3
Infrastructure	727,7	0,0	727,7
Mechanics	277,0	62,6	339,6
Total	10947,1	10948,1	21895,2

Costs in k€ per year: Expected Cost purchasing 7 to 8 detectors/year (VAT Excluded)

Item	2021	2022	2023	2024	2025	2026	2027	2028	2029	2030	Total
Detector	64/21	72/24	80/26	88/29	96/31	104/34	111/37	119/40	127/43	135/45	14228,6
Cryostat	1214,5	1357,7	1378,1	1398,7	1419,7	1441,0	1327,9	1540,4	1563,5	1587,0	14228,6
Electronics	225,1	228,5	338,7	235,4	238,9	354,2	359,5	364,9	370,4	375,9	3091,4
Electronics Upgrade	0,0	345,8	0,0	0,0	54,3	275,7	372,6	0,0	383,8	0,0	1432,2
Electronics Upgrade	340,7	0,0	438,8	0,0	0,0	0,0	0,0	0,0	0,0	0,0	779,5
GTS/SMART	0,0	0	104,6	0,0	0,0	0,0	0,0	0,0	0,0	0,0	104,6
PSA & Data Flow	0,0	157,9	0,0	284,4	52,5	53,3	151,0	48,0	55,7	113,1	915,8
Storage	0,0	117,6	0,0	0,0	0,0	124,9	0,0	0,0	0,0	0,0	242,5
Analysis	0,0	10,5	0,0	0,0	0,0	11,1	0,0	0,0	0,0	11,8	33,3
Infrastructure	461,0	0,0	0,0	266,6	0,0	0,0	0,0	0,0	0,0	0,0	727,7
Mechanics	169,8	0,0	0,0	96,3	10,9	11,1	16,9	17,2	17,4	0,0	339,6
Total	2411,1	2218,0	2260,1	2281,5	1776,4	2271,2	2227,9	1970,5	2390,8	2087,7	21895,2

**Average Expected Cost per ATC
with no discount**

Item	Cost in k€
Detector (×3)	678,6
Cryostat (×1)	127,5
Electronics (×3) + GTS/SMART	59,9
PSA & Data Flow + Storage + Analysis	45,8
Infrastructure	28,0
Mechanics	13,1
Total	952,9

**Average Expected Cost per ATC
with discount for purchasing
7 to 8 encapsulated detectors/year**

Item	Cost in k€
Detector (×3)	547,3
Cryostat (×1)	118,9
Electronics (×3) + GTS/SMART	59,1
PSA & Data Flow + Storage + Analysis	45,8
Infrastructure	28,0
Mechanics	13,1
Total	812,1

In both cases, an overall cost of **779,5 k€**, between 2021 and 2025, will need to be added for the upgrade of the early channels of electronics.

AGATA Operational and Maintenance Costs for the AGATA upgrade to 135 Encapsulated Detectors:

The AGATA Operational Cost are largely the repairing and maintenance costs of the AGATA subsystems. It includes as well the costs of maintaining AGATA under cryogenic temperature all the time based on evaporation of LN2.

The following table is the estimate of the AGATA Operational Costs assuming a funding period between 2021 and 2030.

Behind the costs estimates we have the following lifetimes or average time between failures:

- Detector Capsule: we had a large statistics of detector failures in the more than 10 years AGATA is already under working conditions. The average time between failures for an AGATA detector is presently estimated in 13.3 years or a failure rate of 7.5%.
- Electronics and Infrastructure maintenance or replacement have been estimated as well in 13.3 years, failure rate 7.5%.
- The Data Flow items, in particular the processing and Data Flow server farm lifetime is estimated to be about 7 years, corresponding to a failure rate of 14%.

As the AGATA funding scheme doesn't foresee spare parts for most of the items, our maintenance scheme is supporting the repair or replacement of the broken items. Such a scheme was considered more logical in a project extending over a large number of years for which early purchased spare parts could become obsolete before being employed in the set-up. Only for critical elements (like Autofill, Trigger processor, etc...), necessary for the operation of the full array, early purchase of spare element is foreseen.

Operational / Maintenance Costs (VAT Excluded)

Item	2021	2022	2023	2024	2025	2026	2027	2028	2029	2030
Capsules in setup	60	60	66	75	81	90	96	105	111	120
Expected Capsule failures failures Under Warranty	5	5	5	6	6	7	8	8	9	9
Triple Detectors in setup	1	1	1	2	2	2	2	2	2	2
Detector Operation and Maintenance Costs	20	20	22	25	27	30	32	35	37	40
LN2	73.5	73.5	79.5	88.5	94.5	103.5	109.5	118.5	124.5	133.5
Capsule maintenance/repair	206.0	209.1	212.3	215.5	218.7	277.5	337.9	343.0	406.2	412.3
Detector & Cryostat maintenance /repair Including Pre-amplifier exchange...	77.6	78.7	87.9	101.4	111.1	125.3	135.7	150.6	161.6	177.3
Detector laboratories	60	60	60	60	60	60	60	60	60	60
Infrastructure Maintenance Costs										
HV/LV, Autofill, infrastructure	21.8	21.8	23.9	27.2	29.4	32.6	34.8	38.1	40.2	43.5
Electronics and Data Flow Maintenance Costs										
Elect. maintenance/replacement	0.0	43.8	40.5	87.7	94.4	105.1	111.8	122.5	129.2	139.9
Data Flow maintenance/replacement	63	63	69.3	78.7	85.1	94.5	100.8	110.3	116.6	126.0
Other costs										
Grid/Storage costs	24	24	24	24	24	24	24	24	24	24
Shipping costs	25	25	25	27	27	29	31	31	33	33
Mechanics	8	8	8	8	8	8	8	8	8	8
Total operation & maintenance costs	558.8	606.9	630.4	718.0	752.1	859.5	953.5	1005.9	1103.3	1157.5

Annex III: AGATA Phase 2 summary table for additional costs for the completion of the AGATA array from 135 to 180 detectors (4 π)

This annex includes the additional investment costs tables for the completion of the AGATA array to 180 Encapsulated Detectors (4 π) considering the same procurement program of detector/year.

All prices are given VAT excluded.

The investment costs are summarized in the following paragraphs and tables:

The total costs to complete and instrument 4 π of AGATA, evaluated with the known prices for 2019-2020 and our best estimate for increasing price index of 1.5%/year, would be **15511,6 k€**. These will be the funds needed for a procurement plan without discount, as was in fact the case for Phase1.

The total cost to complete and instrument 4 π version of AGATA, evaluated with our best estimate for increasing price index (1.5%/year) and considering the cost reduction offered by, Mirion Technologies for the simultaneous purchasing of 7 or 8 encapsulated detectors, and CTT for ordering 3 or 2 triple cryostats per year, is **13127,8 k€**. **The attached table gives the Expected Costs in k€ per year, purchasing 7 or 8 detectors/year.**

In their quotation, Mirion Technologies, included a maximum increase of the costs of 2.5% per year. With this condition, a maximum cost of **14832,0 k€** for the completion of 4 π of AGATA, is expected.

Additional Costs in k€ per year: **Expected Cost purchasing 7 to 8 capsules/year
(VAT Excluded) to complete the 4 π array**

Item	2031 142/47	2032 150/49	2033 157/52	2034 165/54	2035 172/57	2036 180/60	Total
Detector	1409,4	1575,7	1452,0	1623,3	1495,9	1672,4	9228,7
Cryostat	261,2	265,2	393,1	273,2	405,0	411,0	2008,7
Electronics	395,4	0,0	0,0	413,5	0,0	106,5	915,4
GTS/SMART	23,9	0,0	0,0	0,0	0,0	0,0	23,9
PSA & Data Flow	0,0	156,5	0,0	281,3	0,0	0,0	437,9
Storage	0,0	136,5	0,0	0,0	0,0	0,0	136,5
Analysis	0,0	0,0	0,0	0,0	0,0	0,0	0,0
Infrastructure	289,0	0,0	0,0	0,0	0,0	0,0	289,0
Mechanics	0,0	12,1	18,5	18,8	19,0	19,3	87,7
Total	2379,0	2146,1	1863,6	2610,0	1919,9	2209,2	13127,8